

REVISIONS			
REV.	DESCRIPTION	DATE	APPROVED
A	MOVED HALF-MOON NOTCH TOT OPPOSITE END	4/26/2013	WS
B	INCREASE THICKNESS TO REFLECT PROTOTYPE	5/10/2013	WS
C	ADDED TOLERANCE ON SKIN THICKNESS	5/13/2013	WS

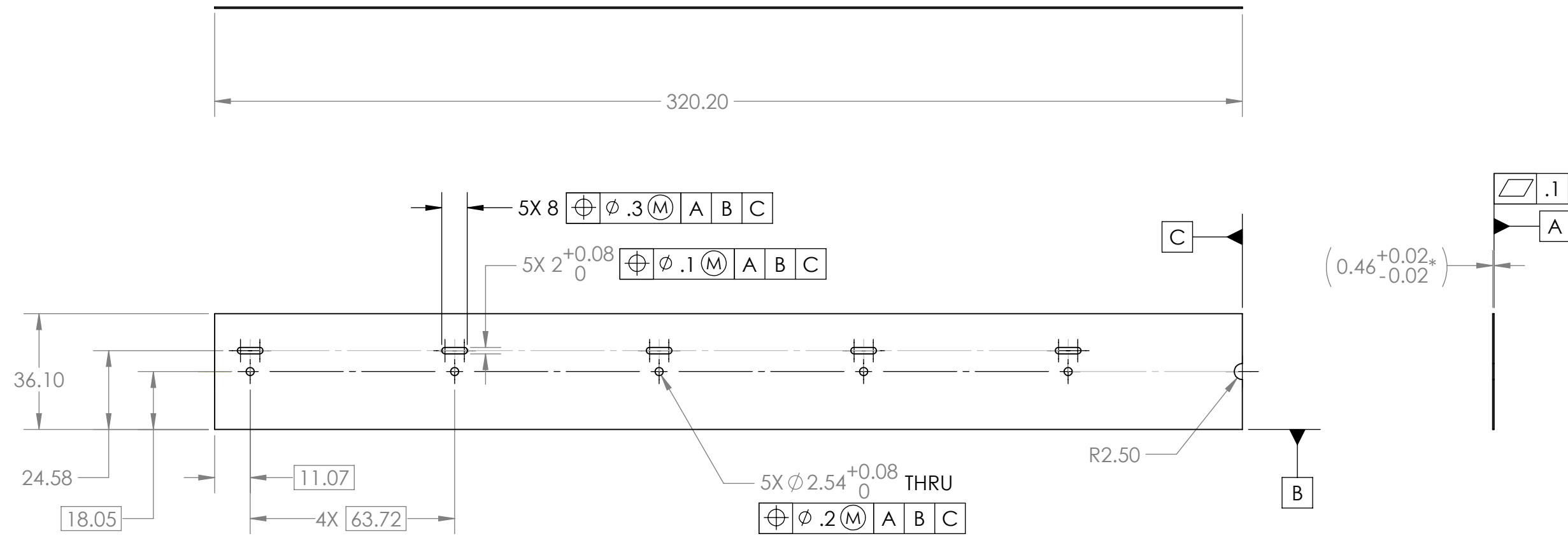

ALL DIMENSIONS IN MILLIMETERS

\*Material: M55J/954-3 GRAPHITE/CYANATE ESTER, 0.063mm CPT, LAYUP [0/+60/-60]s, 6 PLIES, .46 mm TOTAL

<b>P-25</b> SUBATOMIC PHYSICS   LOS ALAMOS NATIONAL LABORATORY LOS ALAMOS, NM, 87545	DIMENSIONS ARE IN INCHES TOLERANCES UNLESS SPECIFIED:		NAME	DATE	<b>80W-Barrel 3 Stave Skin 1</b>	
	FRACTIONAL $\pm$		DRAWN	WALT		3/25/2013
	ANGULAR: MACH $\pm$ BEND $\pm$		CHECKED			
	TWO PLACE DECIMAL $\pm 0.1$		ENG APPR.			
THREE PLACE DECIMAL $\pm 0.05$		MFG APPR.				
MATERIAL		Q.A.		COMMENTS:		
FINISH						
QUANTITY REQUIRED						
1						
SIZE	DWG. NO.			REV.		
<b>B</b>	126Y-1766720			<b>C</b>		
SCALE: 1:1.5	WEIGHT:			SHEET 5 OF 6		