

8 7 6 5 4 3 2 1

REV	SHZONE	REVISIONS		DATE	APPROVED
		DESCRIPTION			
A		Revised & redrawn with all mounting blocks bonded between face sheets		02/12/10	R SMITH

D
C
B
A

D
C
B
A

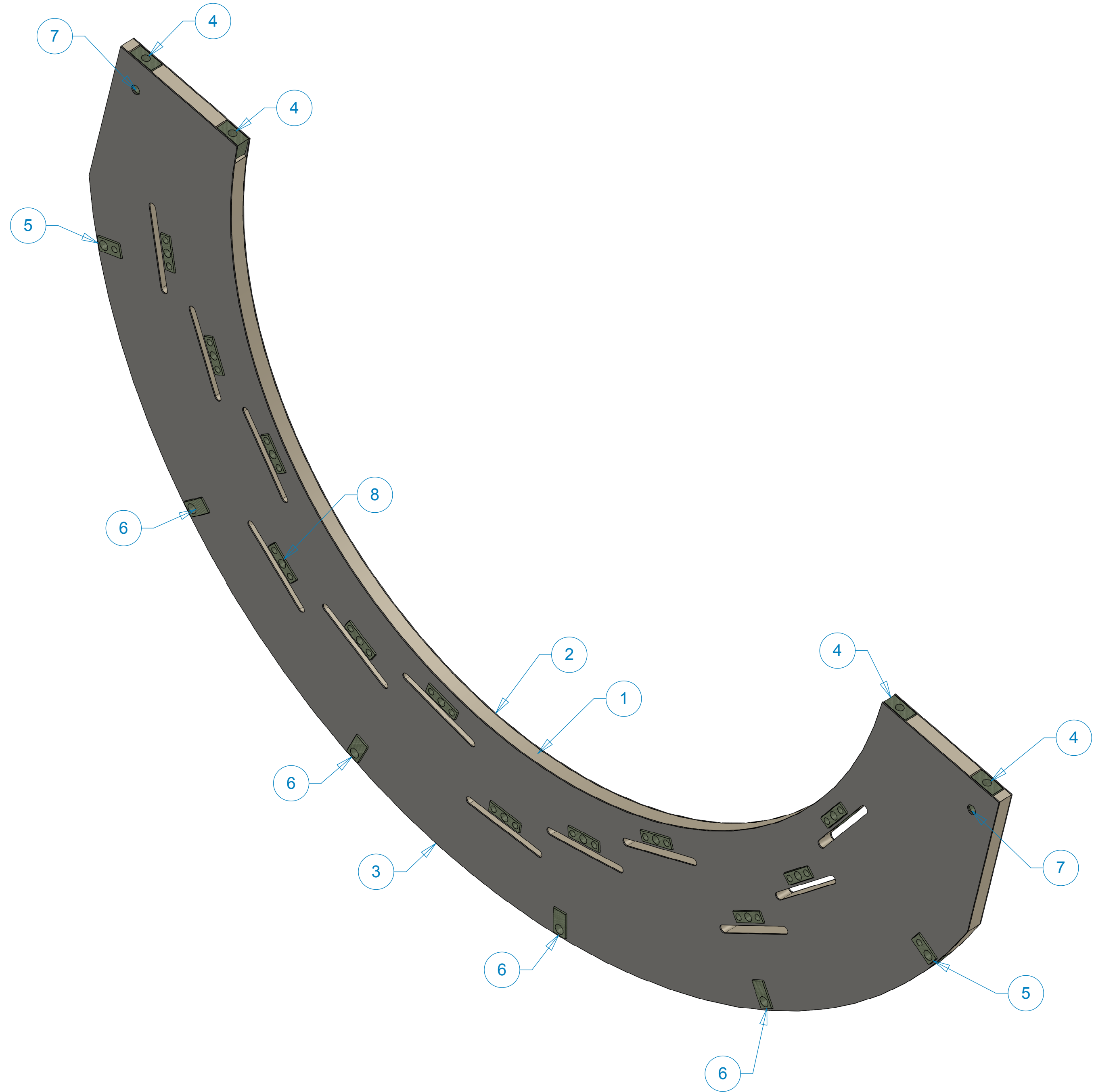

PARTS LIST				
ITEM NO.	QTY.	PART NO.	DESCRIPTION	MATERIAL
1	1		Barrel 4 Support Panel Core	Allcomp K3 or Similar
2	1		Barrel 4 Support Panel Face Skin	M55J/954-3 [0,+60,-60]s
3	1		Barrel 4 Support Panel Face Skin	M55J/954-3 [0,+60,-60]s
4	4	111-PHX-02-2009-1	Barrel 1 Support Insert 2	
5	2	111-PHX-02-2023-1	Barrel 4 Support Insert 1	
6	4	111-PHX-02-2023-3	Barrel 4 Support Insert 2	
7	2	111-PHX-02-2025-1	Barrel 4 Support Insert 3	
8	12	111-PHX-02-2026-1	Barrel 3-4 Ladder Mounting Block	
9	AR		Adhesive	HYSOL 9396



UNLESS OTHERWISE SPECIFIED:
DIMENSIONS ARE IN MILLIMETERS
-TOLERANCES-

DECIMALS	ANGULAR
X = +/- .5	X = +/- .30°
.X = +/- .1	.XX = +/- .15°
.XX = +/- .01	
.XXX = +/- .001	SURFACE FINISH = 250

CAD GENERATED DRAWING.
DO NOT MANUALLY UPDATE
DO NOT SCALE DRAWING

HYTEC, INC

TITLE
**PHENIX CENTRAL UPGRADE
VTX BARREL 4 SUPPORT
ASSEMBLY RIGHT**

THIRD ANGLE PROJECTION

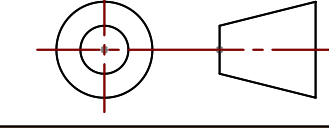

FINISH	SIGNATURE	DATE
	Designer	Roger L. Smith 11/25/2008
	Drawn	Roger L. Smith 11/25/2008
	Checked	RJ Ponchione 6/15/2009
	Engineer	RJ Ponchione 11/25/2008
	Approved	RJ Ponchione 6/15/2009

PART NO.
111-PHX-02-2017-1

DWG. NO. **111-PHX-02-2017 D** SIZE **1 of 3** SHEET NO.

THIS DOCUMENT CONTAINS INFORMATION THAT IS THE PROPRIETARY PROPERTY OF HYTEC, INC.
REPRODUCTION, DISCLOSURE, OR RELEASE TO OTHERS, MANUALLY OR ELECTRONICALLY,
IS STRICTLY PROHIBITED WITHOUT THE PRIOR WRITTEN CONSENT OF HYTEC, INC.

8 7 6 5 4 3 2 1

8 7 6 5 4 3 2 1

D

D

C

C

B

B

A

A

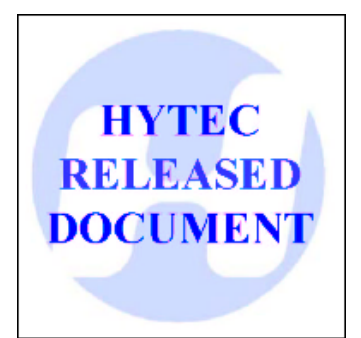
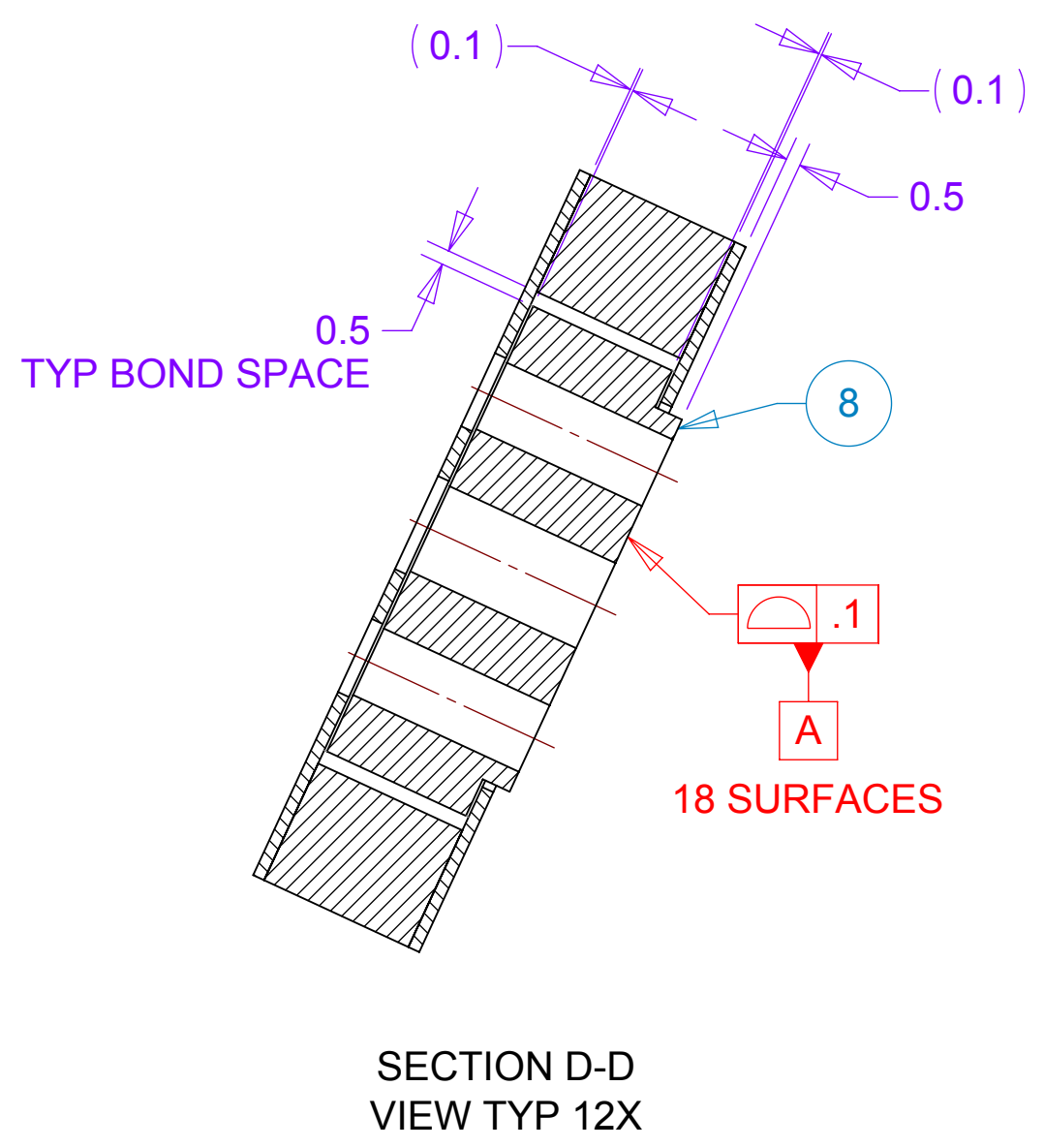
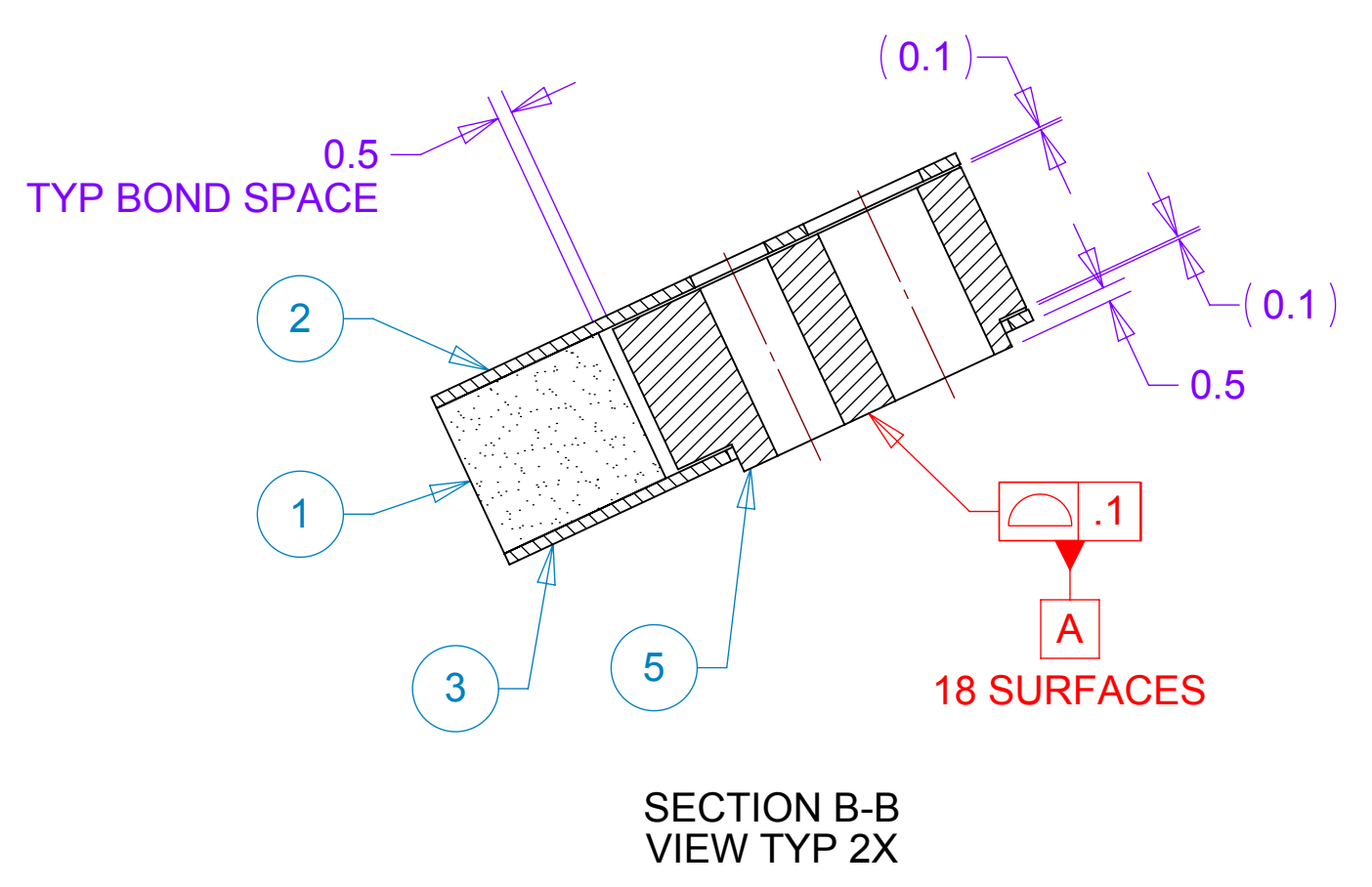
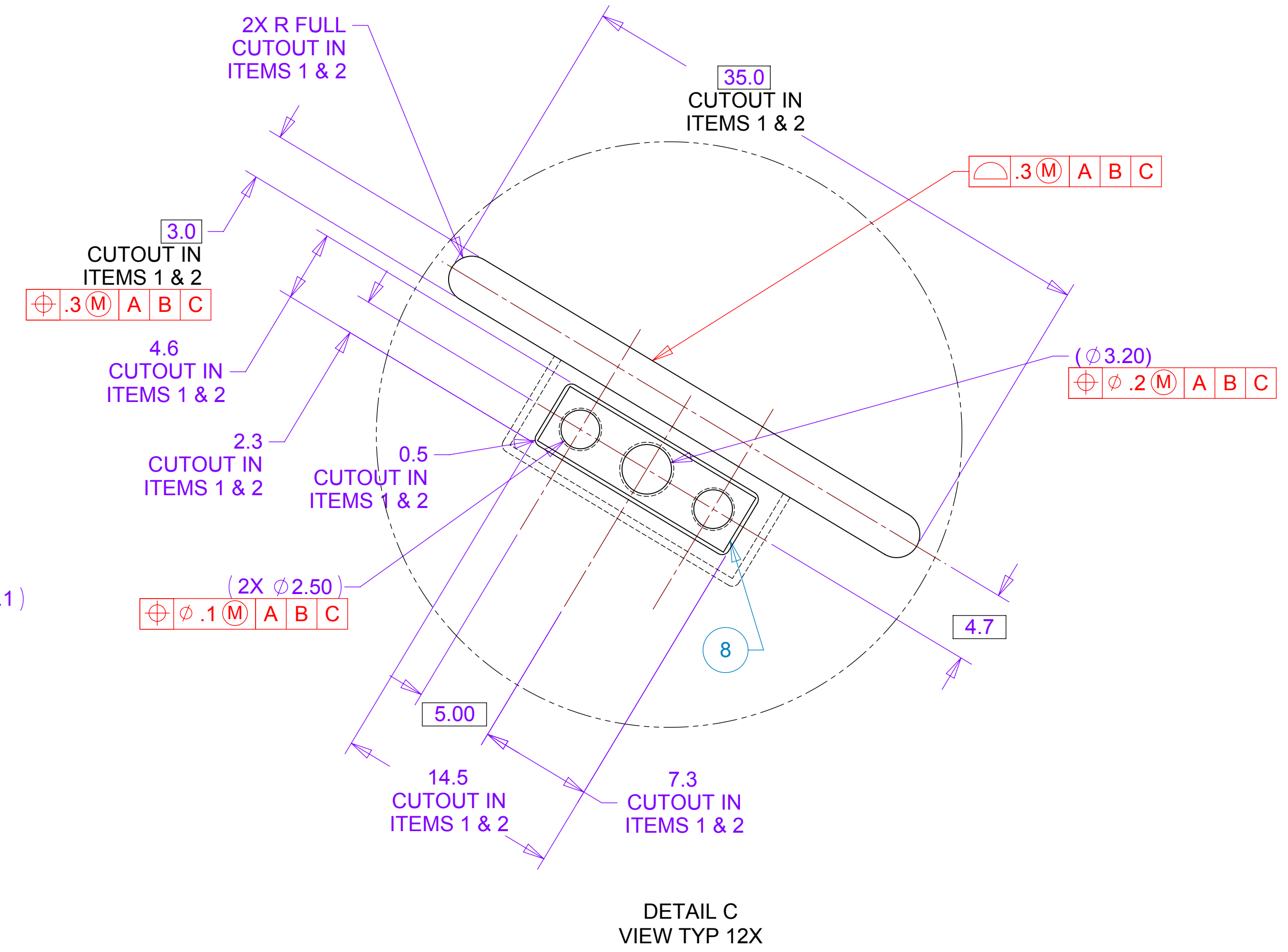
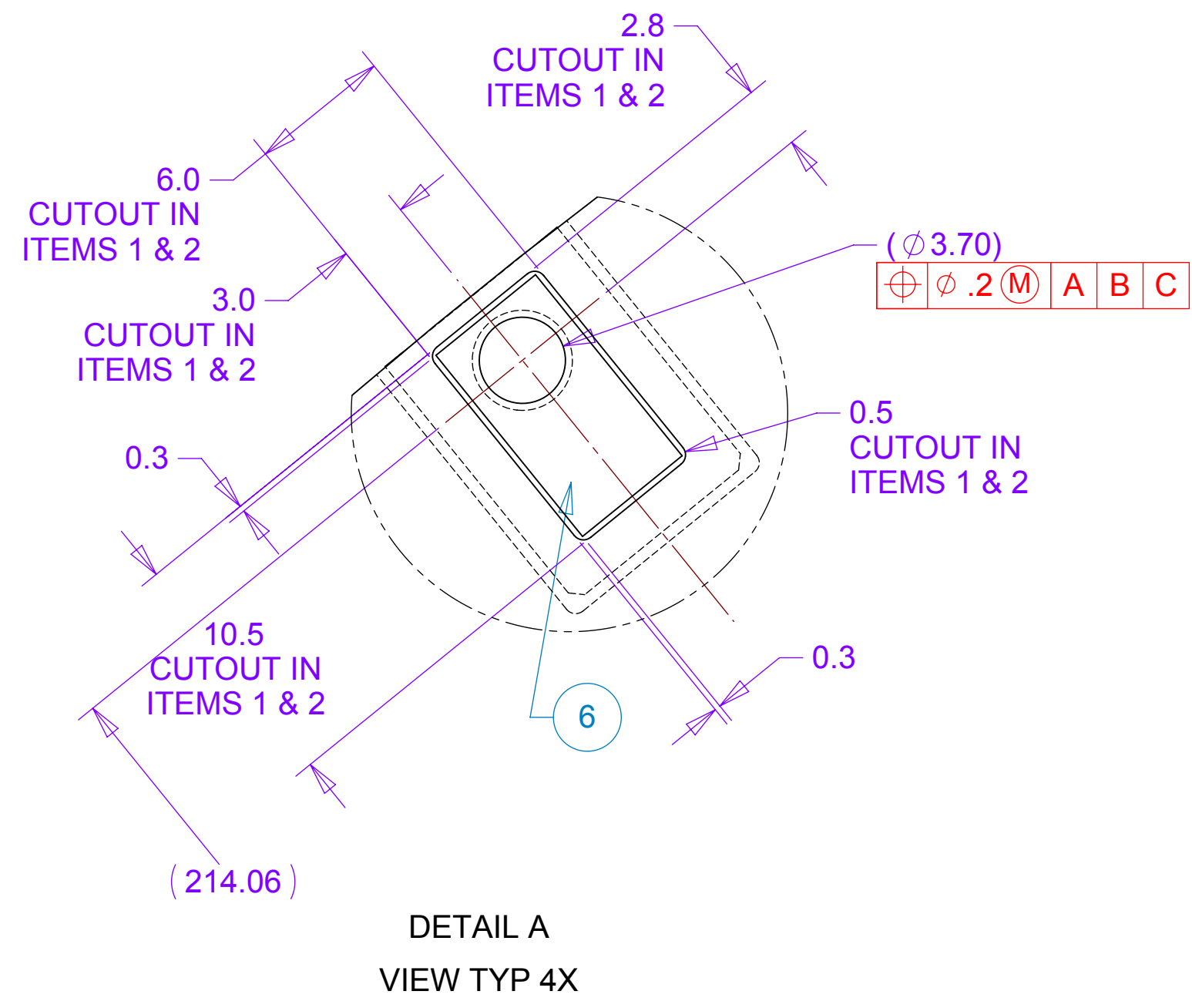

UNLESS OTHERWISE SPECIFIED:
DIMENSIONS ARE IN MILLIMETERS
-TOLERANCES-

DECIMALS	ANGULAR
X = +/- .5	.X = +/- .30°
.X = +/- .1	.XX = +/- .15°
.XX = +/- .01	
.XXX = +/- .001	SURFACE FINISH = 250

FINISH

PART NO.
111-PHX-02-2017-1

CAD GENERATED DRAWING.
DO NOT MANUALLY UPDATE
DO NOT SCALE DRAWING

	SIGNATURE	DATE
Designer	Roger L. Smith	11/25/2008
Drawn	Roger L. Smith	11/25/2008
Checked	RJ Ponchione	6/15/2009
Engineer	RJ Ponchione	11/25/2008
Approved	RJ Ponchione	6/15/2009

HYTEC, INC

TITLE
**PHENIX CENTRAL UPGRADE
VTX BARREL 4 SUPPORT
ASSEMBLY RIGHT**

DWG. NO.	SIZE	SHEET NO.
111-PHX-02-2017	D	3 of 3
SCALE 4:1	REVISION A	

THIS DOCUMENT CONTAINS INFORMATION THAT IS THE PROPRIETARY PROPERTY OF HYTEC, INC.
REPRODUCTION, DISCLOSURE, OR RELEASE TO OTHERS, MANUALLY OR ELECTRONICALLY,
IS STRICTLY PROHIBITED WITHOUT THE PRIOR WRITTEN CONSENT OF HYTEC, INC.

8 7 6 5 4 3 2 1