

Specification for

# ISO metric screw threads —

## Part 1: Principles and basic data

UDC 621.882.082.1

## Cooperating organizations

The Mechanical Engineering Standards Committee, under whose direction this British Standard was prepared, consists of representatives from the following:

Associated Offices Technical Committee	Department of Trade (Marine Division)
Association of Consulting Engineers	Department of Transport
Association of Hydraulic Equipment Manufacturers	Electricity Supply Industry in England and Wales
Association of Mining Electrical and Mechanical Engineers	Engineering Equipment Users' Association
British Compressed Air Society	Federation of Manufacturers of Construction Equipment and Cranes
British Electrical and Allied Manufacturers' Association (BEAMA)*	Health and Safety Executive
British Gas Corporation	Institution of Gas Engineers
British Gear Manufacturers' Association	Institution of Mechanical Engineers
British Internal Combustion Engine Manufacturers' Association*	Institution of Plant Engineers
British Pump Manufacturers' Association	Institution of Production Engineers
British Steel Corporation	LLoyd's Register of Shipping
British Steel Industry	London Transport Executive
British Valve Manufacturers' Association Ltd.	Machine Tool Industry Research Association
Cbmpe	Ministry of Defence*
Chartered Institution of Building Services	National Coal Board*
Crown Agents for Oversea Governments and Administrations	Oil Companies Materials Association
Department of the Environment (PSA)	Process Plant Association
Department of Industry (Mechanical Engineering)	Railway Industry Association of Great Britain*
Department of Industry (National Engineering Laboratory)*	Society of Motor Manufacturers and Traders Limited
	Telecommunication Engineering and Manufacturing Association (TEMA)*

The organizations marked with an asterisk in the above list, together with the following, were directly represented on the Technical Committee entrusted with the preparation of this British Standard:

Agricultural Engineers' Association	Gauge and Tool Makers' Association
Bicycle Association of Great Britain	Screw Thread Tool Manufacturers' Association
British Industrial Fasteners Federation	Society of British Aerospace Companies Limited
British Railways Board	Individual manufacturer
Business Equipment Trade Association	
Fasteners and Turned Parts Institute	

### Amendments issued since publication

Amd. No.	Date of issue	Comments
3910	May 1982	
4701	December 1984	Indicated by a sideline in the margin

This British Standard, having been prepared under the direction of the Mechanical Engineering Standards Committee, was published under the authority of the Executive Board and comes into effect on 31 March 1981

© BSI 02-1999

First published June 1963  
First revision March 1981

The following BSI references relate to the work on this standard:  
Committee reference MEE/1  
Draft for comment 78/80250 DC

ISBN 0 580 11626 3

# Contents

	Page
Cooperating organizations	Inside front cover
Foreword	ii
<hr/>	
1 Scope	1
2 References	1
3 Basic profile	1
4 General plan	2
5 Basic dimensions	6
6 Tolerances: principles and basic data	14
7 Tolerances: deviations for constructional threads	29
<hr/>	
Appendix A Notes for guidance	47
Appendix B Outline guide and examples for calculating limits of size of untabulated metric screw threads	49
<hr/>	
Figure 1 — Basic profile of ISO metric thread	1
Figure 2 — Basic dimensions	6
Figure 3 — Tolerance positions with respect to zero line (basic size)	15
Figure 4 — Nut threads with tolerance position G	17
Figure 5 — Nut threads with tolerance position H	17
Figure 6 — Bolt threads with tolerance positions e, f and g	18
Figure 7 — Bolt threads with tolerance position h	18
Figure 8 — Bolt root profile	26
Figure 9 — Maximum material profiles for internal and external threads	47
<hr/>	
Table 1 — Basic profile dimensions	2
Table 2 — Maximum diameters	3
Table 3 — Diameter/pitch combinations	4
Table 4 — Basic dimensions	7
Table 5 — Fundamental deviations for nut threads and bolt threads	19
Table 6 — Lengths of thread engagement	20
Table 7 — Minor diameter tolerances of nut thread ( $T_{D_1}$ )	21
Table 8 — Major diameter tolerance of bolt thread ( $T_d$ )	22
Table 9 — Pitch diameter tolerance of nut thread ( $T_{D_2}$ )	23
Table 10 — Pitch diameter tolerance of bolt thread ( $T_{d_2}$ )	24
Table 11 — Minimum root radii	25
Table 12 — Tolerance classes for nuts	26
Table 13 — Tolerance classes for bolts	28
Table 14 — Deviations	30
<hr/>	
Publications referred to	Inside back cover

## Foreword

This revised British Standard has been prepared under the direction of the Mechanical Engineering Standards Committee. It is based on the following ISO standards relating to ISO metric screw threads prepared by Technical Committee ISO/TC 1, Screw threads, of the International Organization for Standardization (ISO). The clauses in this standard have been so arranged that each relates directly to the relevant ISO standard as indicated:

Clause 3: ISO 68-1963

Clause 4: ISO 261-1973

Clause 5: ISO 724-1968

Clause 6: ISO 965/1-1980

Clause 7: ISO 965/3-1980

ISO 965/2-1973 *“ISO general purpose metric screw threads — Tolerances — Part II Limits of sizes for commercial bolt and nut threads — Medium quality”*, has not been included as a separate clause in this standard as the limits of sizes listed are specified in BS 3643-2.

ISO 965 has been revised by ISO/TC 1 to include the tolerance position “F” and the modified bolt root profile. This information has been included in this standard.

Screw thread terms and definitions can be found in BS 6528 (identical with ISO 5408-1983) and these will be adopted in future standards and revised existing standards.

Some terms used in this standard, based on the established ISO standards, may be at variance with, or do not appear in, BS 6528; e.g. “crest diameter” is used in clause 6 but is not defined in BS 6528. However it has been decided to leave this descriptive term which is used to embrace the terms “major diameter of bolt thread” and “minor diameter of nut thread”. Moreover the term “nominal size or “nominal diameter” is often confused with basic size, whereas it is now defined in BS 6528 as “The size which is used for the purpose of general identification. It is generally the basic major diameter of the thread”.

ISO 262 “ISO general purpose metric screw threads — Selected sizes for screws, bolts and nuts”, has not been included as a separate clause in this standard as those sizes will be specified in the various product standards. However, its contents form part of Table 3 in clause 4.

In order to establish a recognized fine series, a selection of diameter/pitch combinations has been taken from ISO 261. For nominal diameters up to and including M7, one pitch only for each nominal diameter is included in ISO 261 (other than the coarse pitch) and therefore these pitches have been included in this standard. The pitches for nominal diameters larger than M7 have been extracted from ISO 262.

The information given in Appendix A has been given in this form rather than in the appropriate clauses in the standard, so that each clause maintains as far as possible the ISO format, to enable direct cross reference with the ISO standards and the standards of other countries that are also based on the ISO standards.

The information given in Appendix B for the calculation of limits of size for screw threads recognizes that the limitations of the ISO standards on nominal sizes, i.e. 1.0 mm (minimum) to 300 mm (maximum) diameters and also the diameter/pitch combinations may at times need to be exceeded.

When screw threads for aerospace purposes are specified to comply with the requirements of BS 3643, it is permissible for them to be manufactured to the MJ profile in BS 6293 and for their limits of size to be modified accordingly to suit the root radius of that profile. Attention is drawn to the fact that the MJ threads specified in BS 6293 is the preferred series for aerospace use.

**Terminology and conventions.** For ease of production it has been found convenient to reproduce the tables of the international standards with amendments, where necessary. Some terminology and certain conventions are not identical with those used in British Standards; attention is especially drawn to the following.

The comma has been used throughout as a decimal marker. In British Standards it is current practice to use a full point on the baseline as the decimal marker.

A British Standard does not purport to include all the necessary provisions of a contract. Users of British Standards are responsible for their correct application.

**Compliance with a British Standard does not of itself confer immunity from legal obligations.**

#### **Summary of pages**

This document comprises a front cover, an inside front cover, pages i to iv, pages 1 to 52, an inside back cover and a back cover.

This standard has been updated (see copyright date) and may have had amendments incorporated. This will be indicated in the amendment table on the inside front cover.



## 1 Scope

This Part of this British Standard specifies the principles and basic data for single-start, parallel screw threads having the ISO basic profile for triangular screw threads. Data for 1,0 mm to 300 mm diameter threads is tabulated and Appendix B is included giving the information necessary to calculate the limits of size for exception to the tabulated data.

NOTE Attention is drawn to the fact that, with the different screw thread forms available, there is the possibility of mismatch. It is the responsibility of the designer of the end product to ensure that this possibility is reduced to a minimum. For further information see PD 6494.

## 2 References

The titles of the standards publications referred to in this standard are listed on the inside back cover.

BS 3643-2 specifies the fundamental deviations, tolerances and limits of size for the tolerances classes 4H, 5H, 6H and 7H for internal threads and 4h, 6g and 8g for external threads where appropriate for:

- course pitch series within the range 1 mm to 68 mm diameter;
- fine pitch series with the range 1 mm to 33 mm diameter;
- constant pitch series with the range 8 mm to 300 mm diameter.

The following British Standards will be found useful for reference:

BS 3382, *Electroplated coatings on threaded components.*

BS 4827, *ISO miniature screw threads.*

BS 5346, *ISO metric trapezoidal screw threads.*

## 3 Basic profile

**3.1 General.** This clause specifies the basic profile for ISO general purpose metric screw threads as shown in Figure 1. The dimensions for the various standard pitches are given in Table 1.

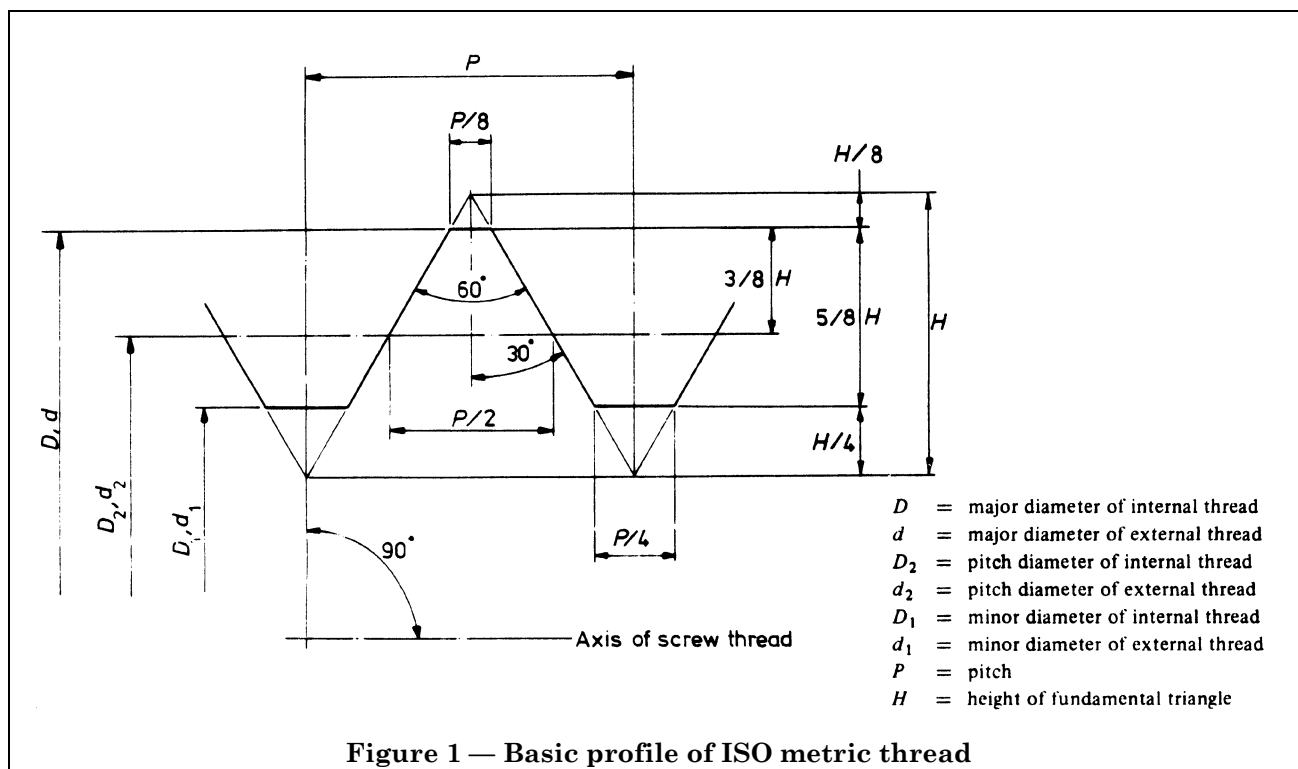

Table 1 — Basic profile dimensions

Dimensions in millimetres

Pitch $P$	$H$	$\frac{5}{8}H$	$\frac{3}{8}H$	$\frac{H}{4}$	$\frac{H}{8}$
0,2	0,173 205	0,108 253	0,064 952	0,043 301	0,021 651
0,25	0,216 506	0,135 316	0,081 190	0,054 127	0,027 063
0,3	0,259 808	0,162 380	0,097 428	0,064 952	0,032 476
0,35	0,303 109	0,189 443	0,113 666	0,075 777	0,037 889
0,4	0,346 410	0,216 506	0,129 904	0,086 603	0,043 301
0,45	0,389 711	0,243 570	0,146 142	0,097 428	0,048 714
0,5	0,433 013	0,270 633	0,162 380	0,108 253	0,054 127
0,6	0,519 615	0,324 760	0,194 856	0,129 904	0,064 952
0,7	0,606 218	0,378 886	0,227 332	0,151 554	0,075 777
0,75	0,649 519	0,405 949	0,243 570	0,162 380	0,081 190
0,8	0,692 820	0,433 013	0,259 808	0,173 205	0,086 603
1	0,866 025	0,541 266	0,324 760	0,216 506	0,108 253
1,25	1,082 532	0,676 582	0,405 949	0,270 633	0,135 316
1,5	1,299 038	0,811 899	0,487 139	0,324 760	0,162 380
1,75	1,515 544	0,947 215	0,568 329	0,378 886	0,189 443
2	1,732 051	1,082 532	0,649 519	0,433 013	0,216 506
2,5	2,165 063	1,353 165	0,811 899	0,541 266	0,270 633
3	2,598 076	1,623 798	0,974 279	0,649 519	0,324 760
3,5	3,031 089	1,894 431	1,136 658	0,757 772	0,378 886
4	3,464 102	2,165 063	1,299 038	0,866 025	0,433 013
4,5	3,897 114	2,435 696	1,461 418	0,974 279	0,487 139
5	4,330 127	2,706 329	1,623 798	1,082 532	0,541 266
5,5	4,763 140	2,976 962	1,786 177	1,190 785	0,595 392
6	5,196 152	3,247 595	1,948 557	1,299 038	0,649 519
8	6,928 203	4,330 127	2,598 076	1,732 051	0,866 025

### 3.2 Definition

#### basic profile

the theoretical profile, associated with the basic sizes of the major, pitch, and minor diameters of the thread  
the deviations are applied to these basic sizes

### 3.3 Dimensions

$$H = \frac{\sqrt{3}}{2}P = 0,866\ 025\ 404\ P$$

$$\frac{5}{8}H = 0,541\ 265\ 877\ P$$

$$\frac{3}{8}H = 0,324\ 759\ 526\ P$$

$$\frac{H}{4} = 0,216\ 506\ 351\ P$$

$$\frac{H}{8} = 0,108\ 253\ 175\ P$$

## 4 General plan

**4.1 General.** This clause specifies ISO general purpose metric screw threads having the basic profile as defined in clause 3.



## 4.2 Choice of diameter and pitch

**4.2.1** Choose, for preference, diameters in column 1 of Table 3 and, if necessary, in column 2 and then in column 3.

**4.2.2** The words “coarse” and “fine” are given in order to conform to usage. No concept of quality shall, however, be associated with these words.

Coarse pitches are the largest metric pitches used in current practice.

**4.2.3** For the diameter (or the diameter range) selected, choose one of the pitches shown on the corresponding line (or lines), avoiding pitches in parentheses.

**4.2.4** If screw threads finer than those given in Table 3 are found to be necessary, only the following pitches shall be used:

$$3 - 2 - 1,5 - 1 - 0,75 - 0,5 - 0,35 - 0,25 - 0,2$$

When selecting such pitches, take into account the fact that there is increasing difficulty in complying with tolerances as the diameter is increased for a given pitch.

NOTE It is suggested, for the time being, that diameters larger than those shown in Table 2 should generally not be used with the pitches indicated.

**Table 2 — Maximum diameters**

Dimensions in millimetres	
Pitch	Maximum diameter
0,5	22
0,75	33
1	80
1,5	150
2	200
3	300

In cases where it is necessary to use a thread with a pitch larger than 6 mm, in the diameter range 150 to 300 mm, the pitch 8 mm should be used for preference.

**4.3 Designation.** For complete designation see 6.4.

A screw thread complying with the requirements of this British Standard shall be designated by the letter M followed by the values of the nominal diameter and of the pitch, expressed in millimetres and separated by the sign ×.

*Example:* M6 × 0,75

The absence of the indication of pitch means that a coarse pitch is specified.

*Example:* M6

Table 3 — Diameter/pitch combinations

Dimensions in millimetres

Nominal diameters			Pitches							
Col. 1 1st choice	Col. 2 2nd choice	Col. 3 3rd choice	coarse series	fine series	constant series					
					3	2	1,5	1,25	1	0,75
1			0,25	0,2						
	1,1		0,25	0,2						
1,2	1,4		0,25 0,3	0,2						
1,6			0,35	0,2						
2	1,8		0,35 0,4	0,2 0,25						
2,5	2,2		0,45	0,25						
3			0,45 0,5	0,35 0,35						
4	3,5		0,6	0,35						
	4,5		0,7 0,75	0,5 0,5						
5			0,8	0,5						
6		5,5	1	(0,5) 0,75						
8	7		1	0,75						
		9	1,25 1,25	1					1	0,75 0,75
10			1,5	1,25					1	0,75
12		11	1,5 1,75	1,25			1,5		1 1	0,75 0,75
	14		2	1,5					1	
16		15	2	1,5			1,5	1,25 <sup>a</sup>	1 1 1	
	18		2,5	1,5			1,5		1	
20		17	2,5	1,5		2			1 1 1	
	22		2,5	1,5		2			1	
24		25	3	2		2	1,5 1,5		1 1 1	
	27		3	2			1,5 1,5 1,5		1 1	
		26								
30		28								
		32	3,5	2	(3)	2	1,5 1,5		1	
	33		3,5	2	(3)		1,5			
		35 <sup>b</sup>								
36		38	4		3	2	1,5 1,5			
	39		4		3	2	1,5			

<sup>a</sup> Only for spark plugs for engines.<sup>b</sup> Only for locking nuts for bearings.

Pitches shown in parentheses are to be avoided, as far as possible.

Table 3 — Diameter/pitch combinations

Dimensions in millimetres

Nominal diameters			Pitches					
Col. 1 1st choice	Col. 2 2nd choice	Col. 3 3rd choice	coarse	constant series				
				6	4	3	2	1,5
42		40				3	2	1,5
	45		4,5		4	3	2	1,5
			4,5		4	3	2	1,5
48		50	5		4	3	2	1,5
	52		5		4	3	2	1,5
		55			4	3	2	1,5
56		58	5,5		4	3	2	1,5
			5,5		4	3	2	1,5
	60	62	6		4	3	2	1,5
64			6		4	3	2	1,5
			6		4	3	2	1,5
	68	65			4	3	2	1,5
		70	6	6	4	3	2	1,5
72		75		6	4	3	2	1,5
	76			6	4	3	2	1,5
		78						
80		82		6	4	3	2	1,5
				6			2	
	85			6	4	3	2	
	95			6	4	3	2	
100				6	4	3	2	
	105			6	4	3	2	
110				6	4	3	2	
	115			6	4	3	2	
	120			6	4	3	2	
125				6	4	3	2	
	130			6	4	3	2	
140		135		6	4	3	2	
				6	4	3	2	
	150	145		6	4	3	2	
		155		6	4	3	2	
160				6	4	3		
				6	4	3		
	170	165		6	4	3		
180		175		6	4	3		
		185		6	4	3		
	190			6	4	3		
200		195		6	4	3		
				6	4	3		
	210	205		6	4	3		
		215		6	4	3		
220				6	4	3		
		225		6	4	3		
		230		6	4	3		
	240	235		6	4	3		
		245		6	4	3		
250				6	4	3		
	260	255		6	4			
				6	4			
		265		6	4			
		270		6	4			
		275		6	4			
280				6	4			
		285		6	4			
		290		6	4			
	300	295		6	4			
				6	4			

## 5 Basic dimensions

**5.1 General.** This clause specifies the basic dimensions, in millimetres, of ISO metric screw threads according to clause 4.

The values refer to the basic profile according to clause 3.

### 5.2 Basic dimensions

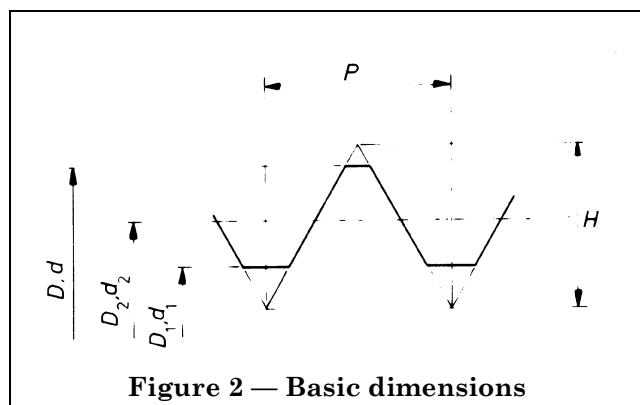

Figure 2 — Basic dimensions

$D$  = basic major diameter of internal thread (nominal diameter)

$d$  = basic major diameter of external thread (nominal diameter)

$D_2$  = basic pitch diameter of internal thread

$d_2$  = basic pitch diameter of external thread

$D_1$  = basic minor diameter of internal thread

$d_1$  = basic minor diameter of external thread

$H$  = height of fundamental triangle

$P$  = pitch

The values of  $D_2$ ,  $d_2$ ,  $D_1$  and  $d_1$  have been calculated from the following formulae and rounded, in the tables, to the third decimal place:

$$D_2 = D - 2 \times \frac{3}{8} H = D - 0,649 5 P$$

$$d_2 = d - 2 \times \frac{3}{8} H = d - 0,649 5 P$$

$$D_1 = D - 2 \times \frac{5}{8} H = D - 1,082 5 P$$

$$d_1 = d - 2 \times \frac{5}{8} H = d - 1,082 5 P$$

Table 4 — Basic dimensions

Nominal diameter = Major diameter <i>D, d</i>	Pitch <i>P</i>	Pitch diameter <i>D<sub>2</sub>, d<sub>2</sub></i>	Minor diameter <i>D<sub>1</sub>, d<sub>1</sub></i>
<b>1</b>	0,25 0,2	0,838 0,870	0,729 0,783
<b>1,1</b>	0,25 0,2	0,938 0,970	0,829 0,883
<b>1,2</b>	0,25 0,2	1,038 1,070	0,929 0,983
<b>1,4</b>	0,3 0,2	1,205 1,270	1,075 1,183
<b>1,6</b>	0,35 0,2	1,373 1,470	1,221 1,383
<b>1,8</b>	0,35 0,2	1,573 1,670	1,421 1,583
<b>2</b>	0,4 0,25	1,740 1,838	1,567 1,729
<b>2,2</b>	0,45 0,25	1,908 2,038	1,713 1,929
<b>2,5</b>	0,45 0,35	2,208 2,273	2,013 2,121
<b>3</b>	0,5 0,35	2,675 2,773	2,459 2,621
<b>3,5</b>	0,6 0,35	3,110 3,273	2,850 3,121
<b>4</b>	0,7 0,5	3,545 3,675	3,242 3,459
<b>4,5</b>	0,75 0,5	4,013 4,175	3,688 3,959
<b>5</b>	0,8 0,5	4,480 4,675	4,134 4,459
<b>5,5</b>	0,5	5,175	4,959
<b>6</b>	1 0,75	5,350 5,513	4,917 5,188
<b>7</b>	1 0,75	6,350 6,513	5,917 6,188
<b>8</b>	1,25 1 0,75	7,188 7,350 7,513	6,647 6,917 7,188
<b>9</b>	1,25 1 0,75	8,188 8,350 8,513	7,647 7,917 8,188
<b>10</b>	1,5 1,25 1 0,75	9,026 9,188 9,350 9,513	8,376 8,647 8,917 9,188

Table 4 — Basic dimensions

Nominal diameter = Major diameter <i>D, d</i>	Pitch <i>P</i>	Pitch diameter <i>D<sub>2</sub>, d<sub>2</sub></i>	Minor diameter <i>D<sub>1</sub>, d<sub>1</sub></i>
11	1,5	10,026	9,376
	1	10,350	9,917
	0,75	10,513	10,188
12	1,75	10,863	10,106
	1,5	11,026	10,376
	1,25	11,188	10,647
	1	11,350	10,917
14	2	12,701	11,835
	1,5	13,026	12,376
	1,25	13,188	12,647
	1	13,350	12,917
15	1,5	14,026	13,376
	1	14,350	13,917
16	2	14,701	13,835
	1,5	15,026	14,376
	1	15,350	14,917
17	1,5	16,026	15,376
	1	16,350	15,917
18	2,5	16,376	15,294
	2	16,701	15,835
	1,5	17,026	16,376
	1	17,350	16,917
20	2,5	18,376	17,294
	2	18,701	17,835
	1,5	19,026	18,376
	1	19,350	18,917
22	2,5	20,376	19,294
	2	20,701	19,835
	1,5	21,026	20,376
	1	21,350	20,917
24	3	22,051	20,752
	2	22,701	21,835
	1,5	23,026	22,376
	1	23,350	22,917
25	2	23,701	22,835
	1,5	24,026	23,376
	1	24,350	23,917
26	1,5	25,026	24,376
27	3	25,051	23,752
	2	25,701	24,835
	1,5	26,026	25,376
	1	26,350	25,917
28	2	26,701	25,835
	1,5	27,026	26,376
	1	27,350	26,917

Table 4 — Basic dimensions

Nominal diameter = Major diameter <i>D, d</i>	Pitch <i>P</i>	Pitch diameter <i>D<sub>2</sub>, d<sub>2</sub></i>	Minor diameter <i>D<sub>1</sub>, d<sub>1</sub></i>
<b>30</b>	3,5	27,727	26,211
	3	28,051	26,752
	2	28,701	27,835
	1,5	29,026	28,376
	1	29,350	28,917
<b>32</b>	2	30,701	29,835
	1,5	31,026	30,376
<b>33</b>	3,5	30,727	29,211
	3	31,051	29,752
	2	31,701	30,835
	1,5	32,026	31,376
<b>35</b>	1,5	34,026	33,376
<b>36</b>	4	33,402	31,670
	3	34,051	32,752
	2	34,701	33,835
	1,5	35,026	34,376
<b>38</b>	1,5	37,026	36,376
<b>39</b>	4	36,402	34,670
	3	37,051	35,752
	2	37,701	36,835
	1,5	38,026	37,376
<b>40</b>	3	38,051	36,752
	2	38,701	37,835
	1,5	39,026	38,376
<b>42</b>	4,5	39,077	37,129
	4	39,402	37,670
	3	40,051	38,752
	2	40,701	39,835
	1,5	41,026	40,376
<b>45</b>	4,5	42,077	40,129
	4	42,402	40,670
	3	43,051	41,752
	2	43,701	42,835
	1,5	44,026	43,376
<b>48</b>	5	44,752	42,587
	4	45,402	43,670
	3	46,051	44,752
	2	46,701	45,835
	1,5	47,026	46,376
<b>50</b>	3	48,051	46,752
	2	48,701	47,835
	1,5	49,026	48,376
<b>52</b>	5	48,752	46,587
	4	49,402	47,670
	3	50,051	48,752
	2	50,701	49,835
	1,5	51,026	50,376

Table 4 — Basic dimensions

Nominal diameter = Major diameter <i>D, d</i>	Pitch <i>P</i>	Pitch diameter <i>D<sub>2</sub>, d<sub>2</sub></i>	Minor diameter <i>D<sub>1</sub>, d<sub>1</sub></i>
<b>55</b>	4	52,402	50,670
	3	53,051	51,752
	2	53,701	52,835
	1,5	54,026	53,376
<b>56</b>	5,5	52,428	50,046
	4	53,402	51,670
	3	54,051	52,752
	2	54,701	53,835
	1,5	55,026	54,376
<b>58</b>	4	55,402	53,670
	3	56,051	54,752
	2	56,701	55,835
	1,5	57,026	56,376
<b>60</b>	5,5	56,428	54,046
	4	57,402	55,670
	3	58,051	56,752
	2	58,701	57,835
	1,5	59,026	58,376
<b>62</b>	4	59,402	57,670
	3	60,051	58,752
	2	60,701	59,835
	1,5	61,026	60,376
<b>64</b>	6	60,103	57,505
	4	61,402	59,670
	3	62,051	60,752
	2	62,701	61,835
	1,5	63,026	62,376
<b>65</b>	4	62,402	60,670
	3	63,051	61,752
	2	63,701	62,835
	1,5	64,026	63,376
<b>68</b>	6	64,103	61,505
	4	65,402	63,670
	3	66,051	64,752
	2	66,701	65,835
	1,5	67,026	66,376
<b>70</b>	6	66,103	63,505
	4	67,402	65,670
	3	68,051	66,752
	2	68,701	67,835
	1,5	69,026	68,376
<b>72</b>	6	68,103	65,505
	4	69,402	67,670
	3	70,051	68,752
	2	70,701	69,835
	1,5	71,026	70,376



Table 4 — Basic dimensions

Nominal diameter = Major diameter <i>D, d</i>	Pitch <i>P</i>	Pitch diameter <i>D<sub>2</sub>, d<sub>2</sub></i>	Minor diameter <i>D<sub>1</sub>, d<sub>1</sub></i>
<b>75</b>	4	72,402	70,670
	3	73,501	71,752
	2	73,701	72,835
	1,5	74,026	73,376
<b>76</b>	6	72,103	69,505
	4	73,402	71,670
	3	74,051	72,752
	2	74,701	73,835
	1,5	75,026	74,376
<b>78</b>	2	76,701	75,835
<b>80</b>	6	76,103	73,505
	4	77,402	75,670
	3	78,051	76,752
	2	78,701	77,835
	1,5	79,026	78,376
<b>82</b>	2	80,701	79,835
<b>85</b>	6	81,103	78,505
	4	82,402	80,670
	3	83,051	81,752
	2	83,701	82,835
<b>90</b>	6	86,103	83,505
	4	87,402	85,670
	3	88,051	86,752
	2	88,701	87,835
<b>95</b>	6	91,103	88,505
	4	92,402	90,670
	3	93,051	91,752
	2	93,701	92,835
<b>100</b>	6	96,103	93,505
	4	97,402	95,670
	3	98,051	96,752
	2	98,701	97,835
<b>105</b>	6	101,103	98,505
	4	102,402	100,670
	3	103,051	101,752
	2	103,701	102,835
<b>110</b>	6	106,103	103,505
	4	107,402	105,670
	3	108,051	106,752
	2	108,701	107,835
<b>115</b>	6	111,103	108,505
	4	112,402	110,670
	3	113,051	111,752
	2	113,701	112,835
<b>120</b>	6	116,103	113,505
	4	117,402	115,670
	3	118,051	116,752
	2	118,701	117,835

Table 4 — Basic dimensions

Nominal diameter = Major diameter <i>D, d</i>	Pitch <i>P</i>	Pitch diameter <i>D<sub>2</sub>, d<sub>2</sub></i>	Minor diameter <i>D<sub>1</sub>, d<sub>1</sub></i>
<b>125</b>	6	121,103	118,505
	4	122,402	120,670
	3	123,051	121,752
	2	123,701	122,835
<b>130</b>	6	126,103	123,505
	4	127,402	125,670
	3	128,051	126,752
	2	128,701	127,835
<b>135</b>	6	131,103	128,505
	4	132,402	130,670
	3	133,051	131,752
	2	133,701	132,835
<b>140</b>	6	136,103	133,505
	4	137,402	135,670
	3	138,051	136,752
	2	138,701	137,835
<b>145</b>	6	141,103	138,505
	4	142,402	140,670
	3	143,051	141,752
	2	143,701	142,835
<b>150</b>	6	146,103	143,505
	4	147,402	145,670
	3	148,051	146,752
	2	148,701	147,835
<b>155</b>	6	151,103	148,505
	4	152,402	150,670
	3	153,051	151,752
<b>160</b>	6	156,103	153,505
	4	157,402	155,670
	3	158,051	156,752
<b>165</b>	6	161,103	158,505
	4	162,402	160,670
	3	163,051	161,752
<b>170</b>	6	166,103	163,505
	4	167,402	165,670
	3	168,051	166,752
<b>175</b>	6	171,103	168,505
	4	172,402	170,670
	3	173,051	171,752
<b>180</b>	6	176,103	173,505
	4	177,402	175,670
	3	178,051	176,752
<b>185</b>	6	181,103	178,505
	4	182,402	180,670
	3	183,051	181,752

Table 4 — Basic dimensions

Nominal diameter = Major diameter <i>D, d</i>	Pitch <i>P</i>	Pitch diameter <i>D<sub>2</sub>, d<sub>2</sub></i>	Minor diameter <i>D<sub>1</sub>, d<sub>1</sub></i>
<b>190</b>	6	186,103	183,505
	4	187,402	185,670
	3	188,051	186,752
<b>195</b>	6	191,103	188,505
	4	192,402	190,670
	3	193,051	191,752
<b>200</b>	6	196,103	193,505
	4	197,402	195,670
	3	198,051	196,752
<b>205</b>	6	201,103	198,505
	4	202,402	200,670
	3	203,051	201,752
<b>210</b>	6	206,103	203,505
	4	207,402	205,670
	3	208,051	206,752
<b>215</b>	6	211,103	208,505
	4	212,402	210,670
	3	213,051	211,752
<b>220</b>	6	216,103	213,505
	4	217,402	215,670
	3	218,051	216,752
<b>225</b>	6	221,103	218,505
	4	222,402	220,670
	3	223,051	221,752
<b>230</b>	6	226,103	223,505
	4	227,402	225,670
	3	228,051	226,752
<b>235</b>	6	231,103	228,505
	4	232,402	230,670
	3	233,051	231,752
<b>240</b>	6	236,103	233,505
	4	237,402	235,670
	3	238,051	236,752
<b>245</b>	6	241,103	238,505
	4	242,402	240,670
	3	243,051	241,752
<b>250</b>	6	246,103	243,505
	4	247,402	245,670
	3	248,051	246,752
<b>255</b>	6	251,103	248,505
	4	252,402	250,670
<b>260</b>	6	256,103	253,505
	4	257,402	255,670
<b>265</b>	6	261,103	258,505
	4	262,402	260,670

Table 4 — Basic dimensions

Nominal diameter = Major diameter $D, d$	Pitch $P$	Pitch diameter $D_2, d_2$	Minor diameter $D_1, d_1$
270	6	266,103	263,505
	4	267,402	265,670
275	6	271,103	268,505
	4	272,402	270,670
280	6	276,103	273,505
	4	277,402	275,670
285	6	281,103	278,505
	4	282,402	280,670
290	6	286,103	283,505
	4	287,402	285,670
295	6	291,103	288,505
	4	292,402	290,670
300	6	296,103	293,505
	4	297,402	295,670

## 6 Tolerances: principles and basic data

**6.1 General.** This clause specifies a tolerance system for screw threads complying with clause 4.

The tolerance system refers to the basic profile according to clause 3.

**6.2 Structure of the tolerance system.** The system gives tolerances defined by tolerance grades and tolerance positions and a selection of grades and positions.

The system provides for:

- a) A series of *tolerance grades* for each of the four screw thread diameters, as follows:

	Tolerance grades
Minor diameter of nut threads ( $D_1$ )	4, 5, 6, 7, 8,
Major diameter of bolt threads ( $d$ )	4, 6, 8,
Pitch diameter of nut threads ( $D_2$ )	4, 5, 6, 7, 8,
Pitch diameter of bolt threads ( $d_2$ )	3, 4, 5, 6, 7, 8, 9

Details of tolerance grades and combinations of tolerance grades for pitch and crest diameters according to tolerance quality and length of engagement group required, with an order of preference, are given in 6.11.

b) Series of *tolerance positions*, G and H for nut threads and e, f, g and h for bolt threads. The established tolerance positions comply with the requirements of current coating thicknesses and with the demands of easy assembly. Tolerance positions with respect to zero line (basic size) are shown in Figure 3.

c) *Selection* of recommended combinations of grades and positions (*tolerance classes*) giving the commonly used tolerance qualities Fine, Medium and Coarse for the three groups of length of thread engagement Short, Normal and Long. Moreover a *further selection of tolerance classes* is given for commercial bolt and nut threads. Tolerance classes other than those shown in 6.11 are not recommended and shall be used only for special cases.

### 6.3 Terminology and symbols

**6.3.1 Terminology.** The term “bolt threads” is used for external screw threads, the term “nut threads” for internal screw threads.

**6.3.2 Symbols.** The following symbols shall be used:

Symbol	Explanation
$D$	basic major diameter of nut thread
$D_1$	basic minor diameter of nut thread
$D_2$	basic pitch diameter of nut thread
$d$	basic major diameter of bolt thread
$d_1$	basic minor diameter of bolt thread
$d_2$	basic pitch diameter of bolt thread
$P$	pitch
$H$	height of fundamental triangle
$R$	bolt root radius
S	designation for thread engagement group Short
N	designation for thread engagement group Normal
L	designation for thread engagement group Long
$T$	tolerance
$T_{D_1}, T_{D_2}$	tolerances for $D_1, D_2, d, d_2$
$T_d, T_{d_2}$	
$ei, EI$	lower deviations
$es, ES$	upper deviations

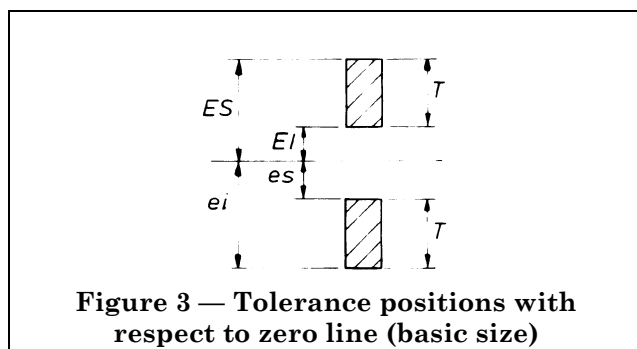

**6.4 Designation.** The complete designation for a screw thread comprises a designation for the thread system and size, and a designation for the thread tolerance class.

The thread designations are given in clause 4.

The tolerance class designation comprises a class designation for the pitch diameter tolerance followed by a class designation for the crest diameter tolerance.

Each class designation consists of

- a figure indicating the tolerance grade;
- a letter indicating the tolerance position, capital for nuts, small for bolts.

If the two class designations for a thread are the same, it is not necessary to repeat the symbols.

*Examples:*

Bolt thread

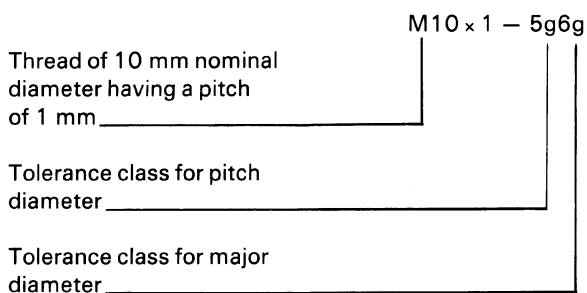
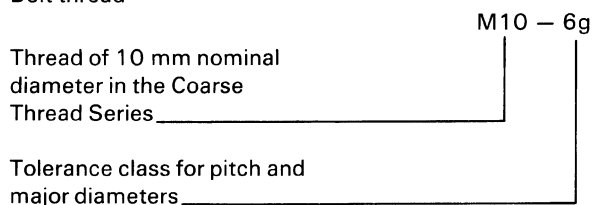

Nut thread

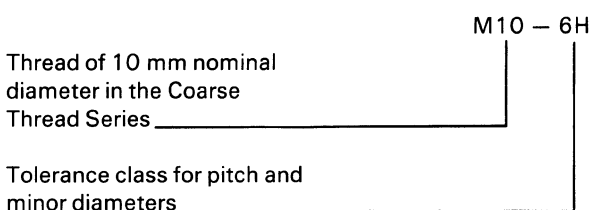

A fit between parts is indicated by the nut thread tolerance class followed by the bolt thread tolerance class separated by an oblique stroke.

*Examples:*

M6 – 6H/6g

M20 × 2 – 6H/5g6g

For coated threads, the tolerances apply to the parts *before* coating, unless otherwise stated. After coating, the actual thread profile shall not in any point transgress the maximum material limits for either position H or h.

**6.5 Tolerance grades.** For each of the two main elements, pitch diameter and crest diameter, a number of tolerance grades have been established. In each case, grade 6 shall be used for tolerance quality Medium and Normal length of thread engagement. The grades below 6 are intended for tolerance quality Fine and/or Short lengths of thread engagement. The grades above 6 are intended for tolerance quality Coarse and/or Long lengths of thread engagement. In some grades, certain tolerance values for small pitches are not shown because of insufficient thread overlap or the requirement that the pitch diameter tolerance shall not exceed the crest diameter tolerance.

**6.6 Tolerance positions.** The following tolerance positions are standardized:

- for nuts: G with positive fundamental deviation  
H with zero fundamental deviation  
See Figure 4 and Figure 5
- for bolts: e, f and g with negative fundamental deviation  
h with zero fundamental deviation  
See Figure 6 and Figure 7

Tolerance position e is, however, limited to pitches 0,5 and coarser.

The values of the fundamental deviations are given in Table 5.

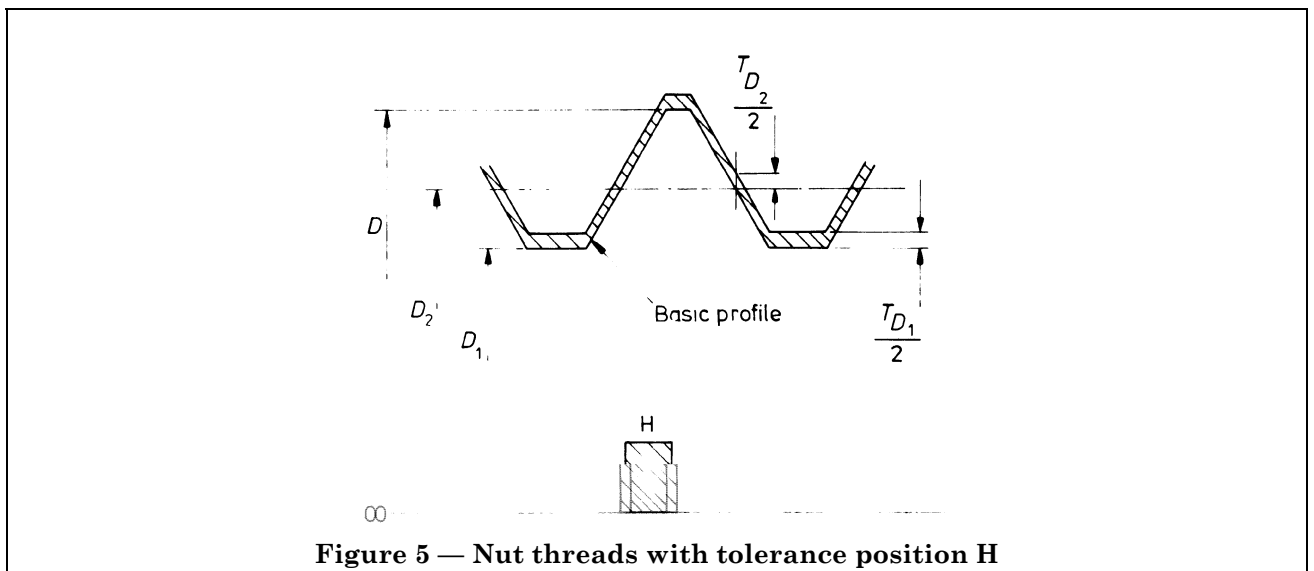
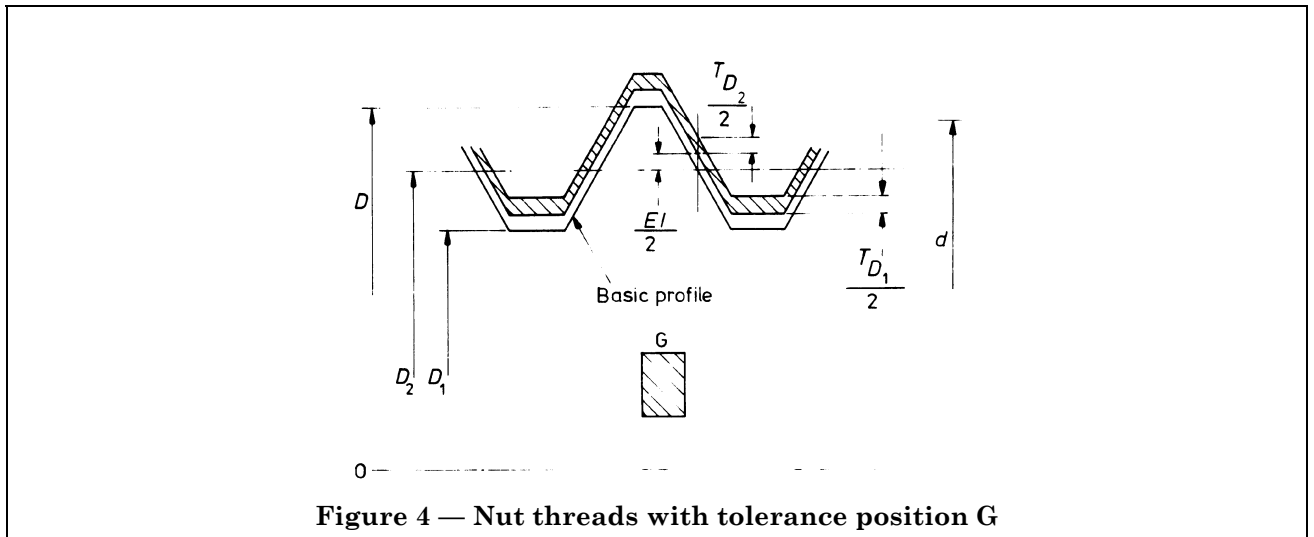

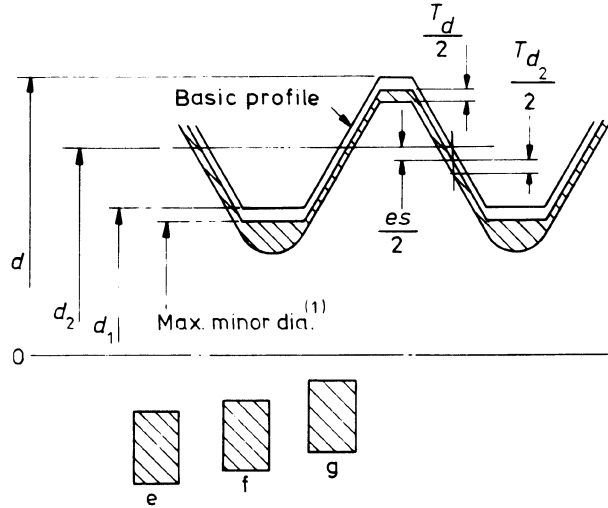

**Figure 6 — Bolt threads with tolerance positions e, f and g**

(1) Applicable only in connection with minimum material flanks ( $d_2$  min). See 6.10 and Figure 8.

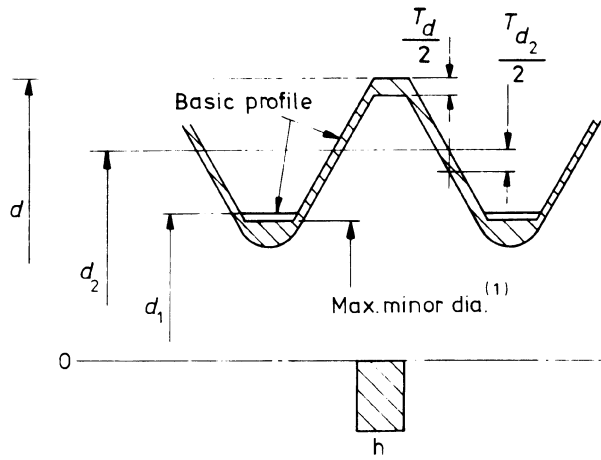

**Figure 7 — Bolt threads with tolerance position h**

(1) Applicable only in connection with minimum material flanks ( $d_2$  min). See 6.10 and Figure 8.



Table 5 — Fundamental deviations for nut threads and bolt threads

Pitch <i>P</i>	Fundamental deviation					
	Nut thread <i>D</i> <sub>2</sub> , <i>D</i> <sub>1</sub>		Bolt thread <i>d</i> , <i>d</i> <sub>2</sub>			
	G <i>EI</i>	H <i>EI</i>	<i>e</i> <i>es</i>	<i>f</i> <i>es</i>	<i>g</i> <i>es</i>	<i>h</i> <i>es</i>
mm	μm	μm	μm	μm	μm	μm
<b>0,2</b>	+ 17	0			– 17	0
<b>0,25</b>	+ 18	0			– 18	0
<b>0,3</b>	+ 18	0			– 18	0
<b>0,35</b>	+ 19	0		– 34	– 19	0
<b>0,4</b>	+ 19	0		– 34	– 19	0
<b>0,45</b>	+ 20	0		– 35	– 20	0
<b>0,5</b>	+ 20	0	– 50	– 36	– 20	0
<b>0,6</b>	+ 21	0	– 53	– 36	– 21	0
<b>0,7</b>	+ 22	0	– 56	– 38	– 22	0
<b>0,75</b>	+ 22	0	– 56	– 38	– 22	0
<b>0,8</b>	+ 24	0	– 60	– 38	– 24	0
<b>1</b>	+ 26	0	– 60	– 40	– 26	0
<b>1,25</b>	+ 28	0	– 63	– 42	– 28	0
<b>1,5</b>	+ 32	0	– 67	– 45	– 32	0
<b>1,75</b>	+ 34	0	– 71	– 48	– 34	0
<b>2</b>	+ 38	0	– 71	– 52	– 38	0
<b>2,5</b>	+ 42	0	– 80	– 58	– 42	0
<b>3</b>	+ 48	0	– 85	– 63	– 48	0
<b>3,5</b>	+ 53	0	– 90	– 70	– 53	0
<b>4</b>	+ 60	0	– 95	– 75	– 60	0
<b>4,5</b>	+ 63	0	– 100	– 80	– 63	0
<b>5</b>	+ 71	0	– 106	– 85	– 71	0
<b>5,5</b>	+ 75	0	– 112	– 90	– 75	0
<b>6</b>	+ 80	0	– 118	– 95	– 80	0

**6.7 Lengths of thread engagement.** The length of thread engagement is classified into one of three groups, short, normal or long in accordance with Table 6.

Table 6 — Lengths of thread engagement

Dimensions in millimetres

Basic major diameter <i>d</i>		Pitch <i>P</i>	Length of thread engagement			
over	up to and incl.		Short up to and incl.	Normal over up to and incl.		Long over
<b>0,99</b>	<b>1,4</b>	0,2	0,5	0,5	1,4	1,4
		0,25	0,6	0,6	1,7	1,7
		0,3	0,7	0,7	2	2
<b>1,4</b>	<b>2,8</b>	0,2	0,5	0,5	1,5	1,5
		0,25	0,6	0,6	1,9	1,9
		0,35	0,8	0,8	2,6	2,6
		0,4	1	1	3	3
		0,45	1,3	1,3	3,8	3,8
<b>2,8</b>	<b>5,6</b>	0,35	1	1	3	3
		0,5	1,5	1,5	4,5	4,5
		0,6	1,7	1,7	5	5
		0,7	2	2	6	6
		0,75	2,2	2,2	6,7	6,7
		0,8	2,5	2,5	7,5	7,5
<b>5,6</b>	<b>11,2</b>	0,75	2,4	2,4	7,1	7,1
		1	3	3	9	9
		1,25	4	4	12	12
		1,5	5	5	15	15
<b>11,2</b>	<b>22,4</b>	1	3,8	3,8	11	11
		1,25	4,5	4,5	13	13
		1,5	5,6	5,6	16	16
		1,75	6	6	18	18
		2	8	8	24	24
		2,5	10	10	30	30
<b>22,4</b>	<b>45</b>	1	4	4	12	12
		1,5	6,3	6,3	19	19
		2	8,5	8,5	25	25
		3	12	12	36	36
		3,5	15	15	45	45
		4	18	18	53	53
		4,5	21	21	63	63
<b>45</b>	<b>90</b>	1,5	7,5	7,5	22	22
		2	9,5	9,5	28	28
		3	15	15	45	45
		4	19	19	56	56
		5	24	24	71	71
		5,5	28	28	85	85
		6	32	32	95	95
<b>90</b>	<b>180</b>	2	12	12	36	36
		3	18	18	53	53
		4	24	24	71	71
		6	36	36	106	106
<b>180</b>	<b>300</b>	3	20	20	60	60
		4	26	26	80	80
		6	40	40	118	118

## 6.8 Crest diameter tolerances

**6.8.1 Minor diameter tolerance of nut thread ( $T_{D_1}$ ).** For the minor diameter tolerance of nut thread,  $T_{D_1}$ , there are five tolerance grades, 4, 5, 6, 7, and 8, in accordance with Table 7.

**Table 7 — Minor diameter tolerances of nut thread ( $T_{D_1}$ )**

Pitch $P$	Tolerance grade				
	4	5	6	7	8
mm	$\mu\text{m}$	$\mu\text{m}$	$\mu\text{m}$	$\mu\text{m}$	$\mu\text{m}$
<b>0,2</b>	38	—	—	—	—
<b>0,25</b>	45	56	—	—	—
<b>0,3</b>	53	67	85	—	—
<b>0,35</b>	63	80	100	—	—
<b>0,4</b>	71	90	112	—	—
<b>0,45</b>	80	100	125	—	—
<b>0,5</b>	90	112	140	180	—
<b>0,6</b>	100	125	160	200	—
<b>0,7</b>	112	140	180	224	—
<b>0,75</b>	118	150	190	236	—
<b>0,8</b>	125	160	200	250	315
<b>1</b>	150	190	236	300	375
<b>1,25</b>	170	212	265	335	425
<b>1,5</b>	190	236	300	375	475
<b>1,75</b>	212	265	335	425	530
<b>2</b>	236	300	375	475	600
<b>2,5</b>	280	355	450	560	710
<b>3</b>	315	400	500	630	800
<b>3,5</b>	355	450	560	710	900
<b>4</b>	375	475	600	750	950
<b>4,5</b>	425	530	670	850	1 060
<b>5</b>	450	560	710	900	1 120
<b>5,5</b>	475	600	750	950	1 180
<b>6</b>	500	630	800	1 000	1 250

**6.8.2 Major diameter tolerance of bolt thread ( $T_d$ ).** For the major diameter tolerance of bolt thread,  $T_d$ , there are three tolerance grades, 4, 6 and 8, in accordance with Table 8.

The tolerance grades 5 and 7 do not exist for the major diameter of bolt threads.

**Table 8 — Major diameter tolerance of bolt thread ( $T_d$ )**

Pitch $P$	Tolerance grade		
	4	6	8
mm	$\mu\text{m}$	$\mu\text{m}$	$\mu\text{m}$
0,2	36	56	—
0,25	42	67	—
0,3	48	75	—
0,35	53	85	—
0,4	60	95	—
0,45	63	100	—
0,5	67	106	—
0,6	80	125	—
0,7	90	140	—
0,75	90	140	—
0,8	95	150	236
1	112	180	280
1,25	132	212	335
1,5	150	236	375
1,75	170	265	425
2	180	280	450
2,5	212	335	530
3	236	375	600
3,5	265	425	670
4	300	475	750
4,5	315	500	800
5	335	530	850
5,5	355	560	900
6	375	600	950

**6.9 Pitch diameter tolerances.** For the pitch diameter tolerance of nut thread,  $T_{D_2}$ , there are five tolerance grades, 4, 5, 6, 7 and 8, in accordance with Table 9.

**Table 9 — Pitch diameter tolerance of nut thread ( $T_{D_2}$ )**

Basic major diameter $d$		Pitch $P$	Tolerance grade				
over	up to and incl.		4	5	6	7	8
mm	mm	mm	$\mu\text{m}$	$\mu\text{m}$	$\mu\text{m}$	$\mu\text{m}$	$\mu\text{m}$
<b>0,99</b>	<b>1,4</b>	0,2	40	—	—	—	—
		0,25	45	56	—	—	—
		0,3	48	60	75	—	—
<b>1,4</b>	<b>2,8</b>	0,2	42	—	—	—	—
		0,25	48	60	—	—	—
		0,35	53	67	85	—	—
		0,4	56	71	90	—	—
		0,45	60	75	95	—	—
<b>2,8</b>	<b>5,6</b>	0,35	56	71	90	—	—
		0,5	63	80	100	125	—
		0,6	71	90	112	140	—
		0,7	75	95	118	150	—
		0,75	75	95	118	150	—
		0,8	80	100	125	160	200
<b>5,6</b>	<b>11,2</b>	0,75	85	106	132	170	—
		1	95	118	150	190	236
		1,25	100	125	160	200	250
		1,5	112	140	180	224	280
<b>11,2</b>	<b>22,4</b>	1	100	125	160	200	250
		1,25	112	140	180	224	280
		1,5	118	150	190	236	300
		1,75	125	160	200	250	315
		2	132	170	212	265	335
		2,5	140	180	224	280	355
<b>22,4</b>	<b>45</b>	1	106	132	170	212	—
		1,5	125	160	200	250	315
		2	140	180	224	280	355
		3	170	212	265	335	425
		3,5	180	224	280	355	450
		4	190	236	300	375	475
<b>45</b>	<b>90</b>	4,5	200	250	315	400	500
		1,5	132	170	212	265	335
		2	150	190	236	300	375
		3	180	224	280	355	450
		4	200	250	315	400	500
		5	212	265	335	425	530
		5,5	224	280	355	450	560
<b>90</b>	<b>180</b>	6	236	300	375	475	600
		2	160	200	250	315	400
		3	190	236	300	375	475
		4	212	265	335	425	530
<b>180</b>	<b>300</b>	6	250	315	400	500	630
		4	212	265	335	425	530
		3	160	200	250	315	400
<b>180</b>	<b>300</b>	4	236	300	375	475	600
		6	265	335	425	530	670
		3	160	200	250	315	400

For the pitch diameter tolerance of bolt thread,  $T_{D_2}$ , there are seven tolerance grades, 3, 4, 5, 6, 7, 8 and 9, in accordance with Table 10.

**Table 10 — Pitch diameter tolerance of bolt thread ( $T_{D_2}$ )**

Basic major diameter $d$		Pitch $P$	Tolerance grade						
over	up to and incl.		3	4	5	6	7	8	9
mm	mm	mm	$\mu\text{m}$	$\mu\text{m}$	$\mu\text{m}$	$\mu\text{m}$	$\mu\text{m}$	$\mu\text{m}$	$\mu\text{m}$
<b>0,99</b>	<b>1,4</b>	0,2	24	30	38	48	—	—	—
		0,25	26	34	42	53	—	—	—
		0,3	28	36	45	56	—	—	—
<b>1,4</b>	<b>2,8</b>	0,2	25	32	40	50	—	—	—
		0,25	28	36	45	56	—	—	—
		0,35	32	40	50	63	80	—	—
		0,4	34	42	53	67	85	—	—
		0,45	36	45	56	71	90	—	—
<b>2,8</b>	<b>5,6</b>	0,35	34	42	53	67	85	—	—
		0,5	38	48	60	75	95	—	—
		0,6	42	53	67	85	106	—	—
		0,7	45	56	71	90	112	—	—
		0,75	45	56	71	90	112	150	190
		0,8	48	60	75	95	118	—	—
		—	—	—	—	—	—	—	—
<b>5,6</b>	<b>11,2</b>	0,75	50	63	80	100	125	—	—
		1	56	71	90	112	140	180	224
		1,25	60	75	95	118	150	190	236
		1,5	67	85	106	132	170	212	265
<b>11,2</b>	<b>22,4</b>	1	60	75	95	118	150	190	236
		1,25	67	85	106	132	170	212	265
		1,5	71	90	112	140	180	224	280
		1,75	75	95	118	150	190	236	300
		2	80	100	125	160	200	250	315
		2,5	85	106	132	170	212	265	335
<b>22,4</b>	<b>45</b>	1	63	80	100	125	160	200	250
		1,5	75	95	118	150	190	236	300
		2	85	106	132	170	212	265	335
		3	100	125	160	200	250	315	400
		3,5	106	132	170	212	265	335	425
		4	112	140	180	224	280	355	450
		4,5	118	150	190	236	300	375	475
<b>45</b>	<b>90</b>	1,5	80	100	125	160	200	250	315
		2	90	112	140	180	224	280	355
		3	106	132	170	212	265	335	425
		4	118	150	190	236	300	375	475
		5	125	160	200	250	315	400	500
		5,5	132	170	212	265	335	425	530
		6	140	180	224	280	355	450	560
<b>90</b>	<b>180</b>	2	95	118	150	190	236	300	375
		3	112	140	180	224	280	355	450
		4	125	160	200	250	315	400	500
		6	150	190	236	300	375	475	600
<b>180</b>	<b>300</b>	3	125	160	200	250	315	400	500
		4	140	180	224	280	355	450	560
		6	160	200	250	315	400	500	630

**6.10 Root contours.** For nut threads as well as bolt threads, the actual root contours shall not at any point transgress the basic profile.

For bolt threads on fasteners with strength grades 8.8 and higher (see BS 6104-1<sup>1)</sup>), the root profile shall have a non-reversing curvature, no portion of which shall have a radius of less than  $0,125 \times P$  (see Table 11).

In the maximum minor diameter position the two radii of  $R_{\min} = 0,125 \times P$  will go through the points of intersection between the maximum material flanks and the minor diameter cylinder of the Go gauges according to BS 919-3 and blend tangentially into the minimum material flanks.

The maximum truncation is:

$$\frac{H}{4} - R_{\min} \left\{ 1 - \cos \left[ \frac{\pi}{3} - \arccos \left( 1 - \frac{T_{d2}}{4 \times R_{\min}} \right) \right] \right\} + \frac{T_{d2}}{2}$$

and the minimum truncation is:

$$0,125 \times P \approx \frac{H}{7}$$

Furthermore a truncation of  $H/6$  ( $R = 0.14434 \times P$ ) is the basis for stress calculations (see clause 7).

NOTE Bolt threads on fasteners with strength grades below 8.8 should preferably comply with the requirements stated above. This is particularly important for fasteners or other screwed connections that are subjected to fatigue or impact. There are, in principle no restrictions other than that the maximum minor diameter of the thread is less than the minimum minor diameter of the Go gauges according to BS 919-3.

**Table 11 — Minimum root radii**

Pitch <i>P</i>	<i>R</i> <sub>min</sub>
mm	mm
0,2	0,025
0,25	0,031
0,3	0,038
0,35	0,044
0,4	0,050
0,45	0,056
0,5	0,063
0,6	0,075
0,7	0,088
0,75	0,094
0,8	0,100
1	0,125
1,25	0,156
1,5	0,188
1,75	0,219
2	0,250
2,5	0,313
3	0,375
3,5	0,438
4	0,500
4,5	0,563
5	0,625
5,5	0,688
6	0,750

<sup>1)</sup> In course of preparation based on ISO 898/1.

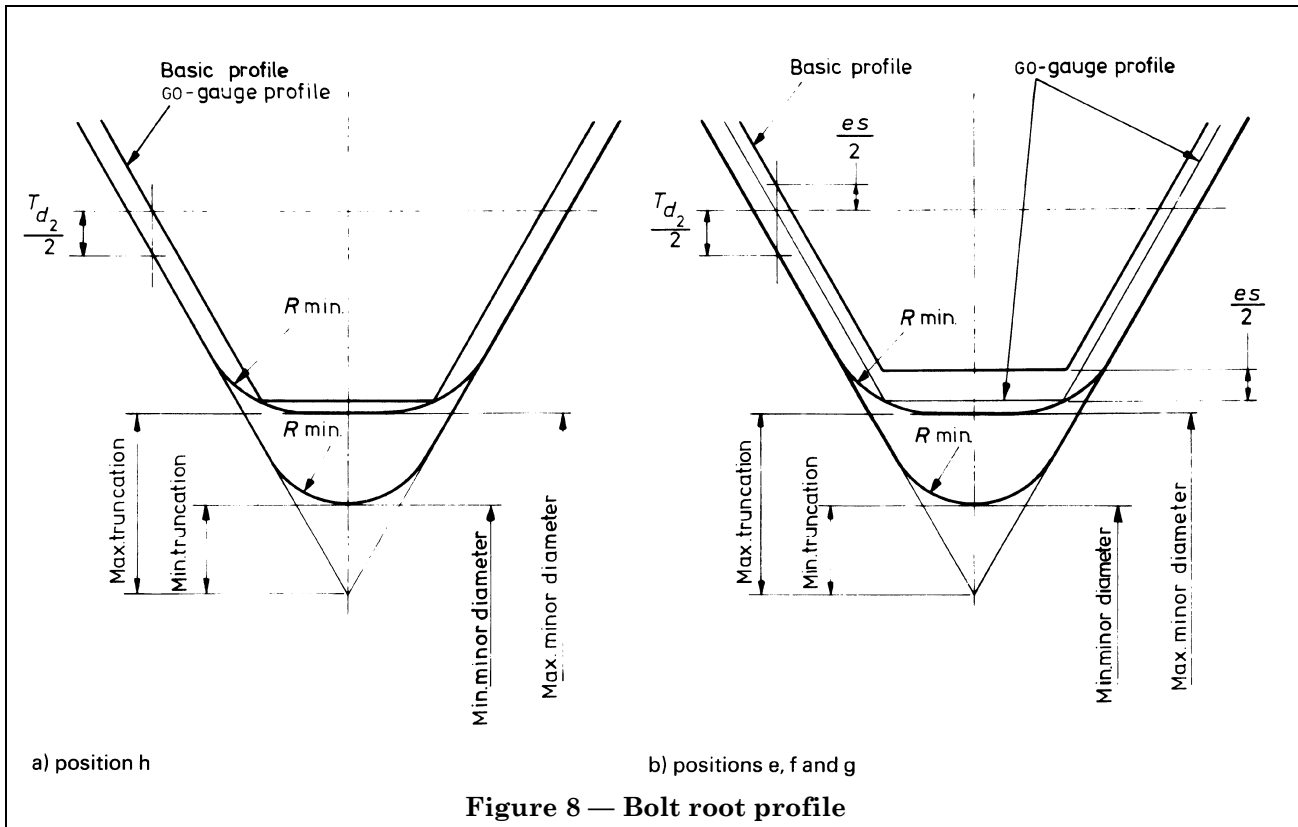

Figure 8 — Bolt root profile

**6.11 Tolerance classes.** In order to reduce the number of gauges and tools, the tolerance classes shall be chosen from Table 12 and Table 13.

The following general rules apply for the choice of tolerance quality:

- Fine: for precision threads, when little variation of fit character is needed.
- Medium: for general use.
- Coarse: for cases where manufacturing difficulties can arise, for example when threading hot-rolled bars and long blind holes.

If the actual length of thread engagement is unknown (as in the manufacturing of standard bolts), normal is recommended.

Table 12 — Tolerance classes for nuts

Tolerance quality	Tolerance position G			Tolerance position H		
	Short	Normal	Long	Short	Normal	Long
Fine				4H	5H	6H
Medium	5G	6G	7G	5H	<b>6H</b>	7H
Coarse		7G	8G		7H	8H

Tolerance classes within frames are selected for commercial bolt and nut threads.

Tolerance classes in bold type are first choice.

Tolerance classes in ordinary type are second choice.

Tolerance classes in sloping type are third choice; they are to be avoided.

NOTE Any of the recommended tolerance classes for nuts can be combined with any of the recommended tolerance classes for bolts with the exception of thread sizes M1,4 and smaller, where the combination 5H/6h or finer shall be chosen. However, in order to guarantee a sufficient overlap, the finished components should preferably be made to form the fits Hg, Hh, or G/h.



## 6.12 Formulae

**6.12.1 General.** The values given in this clause are based on experience. In order to obtain a consistent system, mathematical formulae have been developed.

The values for pitch and crest diameter tolerances and for fundamental deviations have been calculated from the formulae and then rounded off to the nearest value in the R 40 series of preferred numbers. However, when decimal fractions occur, the value has been further rounded off to the nearest whole number.

In order to reproduce a smooth progression, these rules of rounding off have not always been used.

The root radii specified in Table 11 are equal to 0,125 P.

**6.12.2 Fundamental deviations.** The fundamental deviations for nut and bolt threads have been calculated according to the following formulae:

$$\begin{aligned} EI_G &= + (15 + 11 P) & es_e &= - (50 + 11 P)^a \\ EI_H &= 0 & es_f &= - (30 + 11 P) \\ & & es_g &= - (15 + 11 P) \\ & & es_h &= 0 \end{aligned}$$

where

$EI$  and  $es$  are expressed in micrometres;

$P$  is expressed in millimetres.

<sup>a</sup> Exceptions are values for threads with  $P \leq 0,45$  mm

**6.12.3 Length of thread engagement.** For the calculation of the limits of the normal length of thread engagement  $I_N$  in Table 6, the following rule has been applied.

For each pitch within a certain diameter range,  $d$  has been set equal to the smallest diameter (within the range) which appears in clause 4.

$$I_N \text{ min. approximate} = 2,24 P d^{0,2}$$

$$I_N \text{ max. approximate} = 6,7 P d^{0,2}$$

where  $I_N$ ,  $P$  and  $d$  are expressed in millimetres.

### 6.12.4 Crest diameter tolerances

**6.12.4.1 Tolerances for major diameter of bolt thread ( $T_d$ ) grade 6.**

These tolerances have been calculated according to the following formula.

$$T_d(6) = 180 \sqrt[3]{P^2} - \frac{3,15}{\sqrt{P}}$$

where

$T_d$  is expressed in micrometres;

$P$  is expressed in millimetres.

$T_d$  tolerances for the other grades are obtained from the  $T_d(6)$  values (see Table 8) according to the table below.

Tolerance grade		
4	6	8
0,63 $T_d(6)$	$T_d(6)$	1,6 $T_d(6)$

**6.12.4.2 Tolerances for minor diameter of nut thread ( $T_{D_1}$ )** The  $T_{D_1}$  tolerances for grade 6 are calculated according to the following formulae:

a) Pitches 0,2 to 0,8 mm

$$T_{D_1}(6) = 433 P - 190 P^{1,22}$$

b) Pitch 1 mm and coarser

$$T_{D_1}(6) = 230 P^{0,7}$$

where

$T_{D_1}$  is expressed in micrometres;

$P$  is expressed in millimetres.

The values for the other grades are obtained from the  $T_{D_1}(6)$ -values (in Table 7) according to the table below.

Tolerance grade				
4	5	6	7	8
0,63 $T_{D_1}(6)$	0,8 $T_{D_1}(6)$	$T_{D_1}(6)$	1,25 $T_{D_1}(6)$	1,6 $T_{D_1}(6)$

### 6.12.5 Pitch diameter tolerances

6.12.5.1 Tolerances for pitch diameter of bolt thread ( $T_{d_2}$ )  $T_{d_2}(6)$ -values in Table 10 are calculated according to the following formula ( $d$  equal to the geometrical mean value of the diameter range limits):

$$T_{d_2}(6) = 90 P^{0,4} d^{0,1}$$

where

$T_{d_2}$  is expressed in micrometres;

$P$  and  $d$  are expressed in millimetres.

Table 13 — Tolerance classes for bolts

Tolerance quality	Tolerance position e			Tolerance position f			Tolerance position g			Tolerance position h		
	Short	Normal	Long	Short	Normal	Long	Short	Normal	Long	Short	Normal	Long
Fine										3h4h	4h	5h4h
Medium		6e	7e6e		6f		5g6g	6g	7g6g	5h6h	6h	7h6h
Coarse								8g	9g8g			

The values for the other grades are obtained from the  $T_{d_2}(6)$ -values (see Table 10) according to the table below.

Tolerance grade			
3	4	5	6
0,5 $T_{d_2}(6)$	0,63 $T_{d_2}(6)$	0,8 $T_{d_2}(6)$	$T_{d_2}(6)$

7	8	9
1,25 $T_{d_2}(6)$	1,6 $T_{d_2}(6)$	2 $T_{d_2}(6)$

No  $T_{d_2}$ -Values are given in the table when values calculated according to the given formula exceed the  $T_d$ -values in the tolerance grades which are combined in the tables for recommended tolerance classes.

### 6.12.5.2 Tolerances for pitch diameter of nut thread ( $T_{D_2}$ )

$T_{D_2}$  –Values are obtained from the  $T_{D_2}$  (6)–values (see Table 10) according to the table below.

Tolerance grade				
4	5	6	7	8
0,85 $T_{d_1}$ (6)	1,06 $T_{d_2}$ (6)	1,32 $T_{d_2}$ (6)	1,7 $T_{d_2}$ (6)	2,12 $T_{d_2}$ (6)

No  $T_{D_2}$ –values are given in the table when values calculated according to the given formula exceed 0,25  $P$ .

## 7 Tolerances: deviations for constructional threads

**7.1 General.** This clause specifies deviations for pitch and crest diameters for ISO general purpose metric screw threads complying with the requirements of clause 4.

The deviations specified are derived from the fundamental deviations and tolerances specified in clause 6. The values for the deviations are given in Table 14.

**7.2 Designation.** Tolerances are designated by the relevant tolerance class as found under the heading “Tolerance class” in the tables.

Examples:

M6 – 6H

M6 – 5g6g

A fit between threaded parts as indicated by the nut thread tolerance designation followed by the bolt thread tolerance designation separated by an oblique.

Example:

M6 – 6H/5g6g

**7.3 Remarks.** For nut threads as well as bolt threads, the actual root contour shall not in any point transgress the basic profile.

The tabulated deviation values for the minor diameter of the bolt thread are calculated on the basis of an H/6 truncation and may be used for stress calculations.

For coated threads, the tolerances apply to the parts before coating, unless otherwise stated. After coating, the actual thread profile shall not in any point transgress the maximum material limits for either position H or h.

Table 14 — Deviations

*ES, es* = upper deviation*EI, ei* = lower deviation

Basic major diameter		Pitch mm	Nut thread				Bolt thread							
over mm	up to and incl. mm		Tolerance class	Pitch diameter		Minor diameter		Tolerance class	Pitch diameter		Major diameter		Minor diameter <sup>a</sup> (for stress calculations) µm	
				<i>ES</i>	<i>EI</i>	<i>ES</i>	<i>EI</i>		<i>es</i>	<i>ei</i>	<i>es</i>	<i>ei</i>		
				µm	µm	µm	µm	µm	µm	µm	µm	µm		
0,99	1,4	0,2	—	—	—	—	3h4h	0	-24	0	-36	-29		
			4H	+40	0	+38	0	4h	0	-30	0	-36	-29	
			5G	—	—	—	—	5g6g	-17	-55	-17	-73	-46	
			5H	—	—	—	—	5h4h	0	-38	0	-36	-29	
			—	—	—	—	—	5h6h	0	-38	0	-56	-29	
			—	—	—	—	—	6e	—	—	—	—	—	
			—	—	—	—	—	6f	—	—	—	—	—	
			6G	—	—	—	—	6g	-17	-65	-17	-73	-46	
			6H	—	—	—	—	6h	0	-48	0	-56	-29	
			—	—	—	—	—	7e6e	—	—	—	—	—	
			7G	—	—	—	—	7g6g	—	—	—	—	—	
			7H	—	—	—	—	7h6h	—	—	—	—	—	
		8G	—	—	—	—	8g	—	—	—	—	—		
		8H	—	—	—	—	9g8g	—	—	—	—	—		
		0,25	0,25	—	—	—	—	3h4h	0	-26	0	-42	-36	
				4H	+45	0	+45	0	4h	0	-34	0	-42	-36
				5G	+74	+18	+74	+18	5g6g	-18	-60	-18	-85	-54
				5H	+56	0	+56	0	5h4h	0	-42	0	-42	-36
				—	—	—	—	—	5h6h	0	-42	0	-67	-36
				—	—	—	—	—	6e	—	—	—	—	—
				—	—	—	—	—	6f	—	—	—	—	—
				6G	—	—	—	—	6g	-18	-71	-18	-85	-54
				6H	—	—	—	—	6h	0	-53	0	-67	-36
				—	—	—	—	—	7e6e	—	—	—	—	—
				7G	—	—	—	—	7g6g	—	—	—	—	—
				7H	—	—	—	—	7h6h	—	—	—	—	—
		8G	—	—	—	—	8g	—	—	—	—	—		
		8H	—	—	—	—	9g8g	—	—	—	—	—		
		0,3	0,3	—	—	—	—	3h4h	0	-28	0	-48	-43	
				4H	+48	0	+53	0	4h	0	-36	0	-48	-43
				5G	+78	+18	+85	+18	5g6g	-18	-63	-18	-93	-61
				5H	+60	0	+67	0	5h4h	0	-45	0	-48	-43
				—	—	—	—	—	5h6h	0	-45	0	-75	-43
—	—			—	—	—	6e	—	—	—	—	—		
—	—			—	—	—	6f	—	—	—	—	—		
6G	+93			+18	+103	+18	6g	-18	-74	-18	-93	-61		
6H	+75			0	+85	0	6h	0	-56	0	-75	-43		
—	—			—	—	—	7e6e	—	—	—	—	—		
7G	—	—	—	—	7g6g	—	—	—	—	—				

<sup>a</sup> Deviation =  $es + H/6$

Table 14 — Deviations

*ES, es* = upper deviation  
*EI, ei* = lower deviation

Basic major diameter		Pitch mm	Nut thread				Bolt thread							
over mm	up to and incl. mm		Tolerance class	Pitch diameter		Minor diameter		Tolerance class	Pitch diameter		Major diameter		Minor diameter (for stress calculations) µm	
				<i>ES</i>	<i>EI</i>	<i>ES</i>	<i>EI</i>		<i>es</i>	<i>ei</i>	<i>es</i>	<i>ei</i>		
µm	µm			µm	µm	µm	µm		µm	µm	µm	µm		
0,99	1,4	0,3	7H	—	—	—	—	7h6h	—	—	—	—	—	
			8G	—	—	—	—	8g	—	—	—	—	—	
			8H	—	—	—	—	9g8g	—	—	—	—	—	
1,4	2,8	0,2	—	—	—	—	—	3h4h	0	-25	0	-36	-29	
			4H	+42	0	+38	0	4h	0	-32	0	-36	-29	
			5G	—	—	—	—	5g6g	-17	-57	-17	-73	-46	
			5H	—	—	—	—	5h4h	0	-40	0	-36	-29	
			—	—	—	—	—	5h6h	0	-40	0	-56	-29	
			—	—	—	—	—	6e	—	—	—	—	—	
			—	—	—	—	—	6f	-32	-82	-32	-88	-61	
			6G	—	—	—	—	6g	-17	-67	-17	-73	-46	
			6H	—	—	—	—	6h	0	-50	0	-56	-29	
			—	—	—	—	—	7e6e	—	—	—	—	—	
			7G	—	—	—	—	7g6g	—	—	—	—	—	
			7H	—	—	—	—	7h6h	—	—	—	—	—	
		8G	—	—	—	—	8g	—	—	—	—	—		
		8H	—	—	—	—	9g8g	—	—	—	—	—		
		0,25	—	—	—	—	—	—	3h4h	0	-28	0	-42	-36
			4H	+48	0	+45	0	4h	0	-36	0	-42	-36	
			5G	+78	+18	+74	+18	5g6g	-18	-63	-18	-85	-54	
			5H	+60	0	+56	0	5h4h	0	-45	0	-42	-36	
			—	—	—	—	—	5h6h	0	-45	0	-67	-36	
			—	—	—	—	—	6e	—	—	—	—	—	
			—	—	—	—	—	6f	-33	-89	-33	-100	-69	
			6G	—	—	—	—	6g	-18	-74	-18	-85	-54	
			6H	—	—	—	—	6h	0	-56	0	-67	-36	
			—	—	—	—	—	7e6e	—	—	—	—	—	
			7G	—	—	—	—	7g6g	—	—	—	—	—	
			7H	—	—	—	—	7h6h	—	—	—	—	—	
		8G	—	—	—	—	8g	—	—	—	—	—		
		8H	—	—	—	—	9g8g	—	—	—	—	—		
		0,35	—	—	—	—	—	—	3h4h	0	-32	0	-53	-51
			4H	+53	0	+63	0	4h	0	-40	0	-53	-51	
5G	+86		+19	+99	+19	5g6g	-19	-69	-19	-104	-70			
5H	+67		0	+80	0	5h4h	0	-50	0	-53	-51			
—	—		—	—	—	5h6h	0	-50	0	-85	-51			
—	—		—	—	—	6e	—	—	—	—	—			
—	—		—	—	—	6f	-34	-97	-34	-119	-85			
6G	+104		+19	+119	+19	6g	-19	-82	-19	-104	-70			

Table 14 — Deviations

*ES, es* = upper deviation*EI, ei* = lower deviation

Basic major diameter		Pitch mm	Nut thread				Bolt thread							
over mm	up to and incl. mm		Tolerance class	Pitch diameter		Minor diameter		Tolerance class	Pitch diameter		Major diameter		Minor diameter (for stress calculations) µm	
				<i>ES</i>	<i>EI</i>	<i>ES</i>	<i>EI</i>		<i>es</i>	<i>ei</i>	<i>es</i>	<i>ei</i>		
				µm	µm	µm	µm		µm	µm	µm	µm		
1,4	2,8	03,5	6H	+ 85	0	+ 100	0	6h	0	- 63	0	- 85	- 51	
			—	—	—	—	—	7e6e	—	—	—	—	—	
			7G	—	—	—	—	7g6g	- 19	- 99	- 19	- 104	- 70	
			7H	—	—	—	—	7h6h	0	- 80	0	- 85	- 51	
			8G	—	—	—	—	8g	—	—	—	—	—	
		8H	—	—	—	—	9g8g	—	—	—	—	—		
		0,4	—	—	—	—	—	—	3h4h	0	- 34	0	- 60	- 58
			4H	+ 56	0	+ 71	0	4h	0	- 42	0	- 60	- 58	
			5G	+ 90	+ 19	+ 109	+ 19	5g6g	- 19	- 72	- 19	- 114	- 77	
			5H	+ 71	0	+ 90	0	5h4h	0	- 53	0	- 60	- 58	
			—	—	—	—	—	—	5h6h	0	- 53	0	- 95	- 58
			—	—	—	—	—	—	6e	—	—	—	—	—
			—	—	—	—	—	—	6f	- 34	- 101	- 34	- 129	- 92
			6G	+ 109	+ 19	+ 131	+ 19	6g	- 19	- 86	- 19	- 114	- 77	
			6H	+ 90	0	+ 112	0	6h	0	- 67	0	- 95	- 58	
			—	—	—	—	—	—	7e6e	—	—	—	—	—
			7G	—	—	—	—	7g6g	- 19	- 104	- 19	- 114	- 77	
			7H	—	—	—	—	7h6h	0	- 85	0	- 95	- 58	
			8G	—	—	—	—	8g	—	—	—	—	—	
			8H	—	—	—	—	9g8g	—	—	—	—	—	
			0,45	—	—	—	—	—	—	3h4h	0	- 36	0	- 63
		4H		+ 60	0	+ 80	0	4h	0	- 45	0	- 63	- 65	
		5G		+ 95	+ 20	+ 120	+ 20	5g6g	- 20	- 76	- 20	- 120	- 85	
		5H		+ 75	0	+ 100	0	5h4h	0	- 56	0	- 63	- 65	
		—		—	—	—	—	—	5h6h	0	- 56	0	- 100	- 65
		—		—	—	—	—	—	6e	—	—	—	—	—
		—		—	—	—	—	—	6f	- 35	- 106	- 35	- 135	- 100
		6G		+ 115	+ 20	+ 145	+ 20	6g	- 20	- 91	- 20	- 120	- 85	
		6H		+ 95	0	+ 125	0	6h	0	- 71	0	- 100	- 65	
		—		—	—	—	—	—	7e6e	—	—	—	—	—
7G	—	—		—	—	7g6g	- 20	- 110	- 20	- 120	- 85			
7H	—	—		—	—	7h6h	0	- 90	0	- 100	- 65			
8G	—	—		—	—	8g	—	—	—	—	—			
8H	—	—		—	—	9g8g	—	—	—	—	—			
2,8	5,6	0,35		—	—	—	—	—	3h4h	0	- 34	0	- 53	- 51
			4H	+ 56	0	+ 63	0	4h	0	- 42	0	- 53	- 51	
			5G	+ 90	+ 19	+ 99	+ 19	5g6g	- 19	- 72	- 19	- 104	- 70	
			5H	+ 71	0	+ 80	0	5h4h	0	- 53	0	- 53	- 51	
			—	—	—	—	—	—	5h6h	0	- 53	0	- 85	- 51

Table 14 — Deviations

*ES, es* = upper deviation  
*EI, ei* = lower deviation

Basic major diameter		Pitch mm	Nut thread				Bolt thread							
over mm	up to and incl. mm		Tolerance class	Pitch diameter		Minor diameter		Tolerance class	Pitch diameter		Major diameter		Minor diameter (for stress calculations) µm	
				<i>ES</i>	<i>EI</i>	<i>ES</i>	<i>EI</i>		<i>es</i>	<i>ei</i>	<i>es</i>	<i>ei</i>		
				µm	µm	µm	µm	µm	µm	µm	µm	µm		
2,8	5,6	0,35	—	—	—	—	—	6e	—	—	—	—	—	
			—	—	—	—	—	6f	- 34	- 101	- 34	- 119	- 85	
			6G	+ 109	+ 19	+ 119	+ 19	6g	—	—	—	—	—	
			6H	+ 90	0	+ 100	0	6h	—	—	—	—	—	
			—	—	—	—	—	7e6e	—	—	—	—	—	
			7G	—	—	—	—	7g6g	- 19	- 104	- 19	- 104	- 70	
			7H	—	—	—	—	7h6h	0	- 85	0	- 85	- 51	
			8G	—	—	—	—	8g	—	—	—	—	—	
		8H	—	—	—	—	9g8g	—	—	—	—	—		
		—	—	0,5	—	—	—	—	3h4h	0	- 38	0	- 67	- 72
		4H	+ 63		0	+ 90	0	4h	0	- 48	0	- 67	- 72	
		5G	+ 100		+ 20	+ 132	+ 20	5g6g	- 20	- 80	- 20	- 126	- 92	
		5H	+ 80		0	+ 112	0	5h4h	0	- 60	0	- 67	- 72	
		—	—		—	—	—	5h6h	0	- 60	0	- 106	- 72	
		—	—		—	—	—	6e	- 50	- 125	- 50	- 156	- 122	
		—	—		—	—	—	6f	- 36	- 111	- 36	- 142	- 108	
		6G	+ 120		+ 20	+ 160	+ 20	6g	- 20	- 95	- 20	- 126	- 92	
		6H	+ 100		0	+ 140	0	6h	0	- 75	0	- 106	- 72	
		—	—		—	—	—	7e6e	- 50	- 145	- 50	- 156	- 122	
		7G	+ 145		+ 20	+ 200	+ 20	7g6g	- 20	- 115	- 20	- 126	- 92	
		7H	+ 125		0	+ 180	0	7h6h	0	- 95	0	- 106	- 72	
		8G	—	—	—	—	8g	—	—	—	—	—		
		8H	—	—	—	—	9g8g	—	—	—	—	—		
		—	—	0,6	—	—	—	—	3h4h	0	- 42	0	- 80	- 87
		4H	+ 71		0	+ 100	0	4h	0	- 53	0	- 80	- 87	
		5G	+ 111		+ 21	+ 146	+ 21	5g6g	- 21	- 88	- 21	- 146	- 108	
		5H	+ 90		0	+ 125	0	5h4h	0	- 67	0	- 80	- 87	
		—	—		—	—	—	5h6h	0	- 67	0	- 125	- 87	
		—	—		—	—	—	6e	- 53	- 138	- 53	- 178	- 140	
		—	—		—	—	—	6f	- 36	- 121	- 36	- 161	- 123	
		6G	+ 133		+ 21	+ 181	+ 21	6g	- 21	- 106	- 21	- 146	- 108	
		6H	+ 112		0	+ 160	0	6h	0	- 85	0	- 125	- 87	
		—	—		—	—	—	7e6e	- 53	- 159	- 53	- 178	- 140	
		7G	+ 161		+ 21	+ 121	+ 21	7g6g	- 21	- 127	- 21	- 146	- 108	
		7H	+ 140		0	+ 200	0	7h6h	0	- 106	0	- 125	- 87	
		8G	—	—	—	—	8g	—	—	—	—	—		
8H	—	—	—	—	9g8g	—	—	—	—	—				
—	—	0,7	—	—	—	—	3h4h	0	- 45	0	- 90	- 101		
4H	+ 75		0	+ 112	0	4h	0	- 56	0	- 90	- 101			

Table 14 — Deviations

*ES, es* = upper deviation*EI, ei* = lower deviation

Basic major diameter		Pitch	Nut thread				Bolt thread						
over	up to and incl.		Tolerance class	Pitch diameter		Minor diameter		Tolerance class	Pitch diameter		Major diameter		Minor diameter (for stress calculations)
				<i>ES</i>	<i>EI</i>	<i>ES</i>	<i>EI</i>		<i>es</i>	<i>ei</i>	<i>es</i>	<i>ei</i>	
mm	mm			mm	μm	μm	μm		μm	μm	μm	μm	
2,8	5,6	0,7	5G	+ 117	+ 22	+ 162	+ 22	5g6g	- 22	- 93	- 22	- 162	- 123
			5H	+ 95	0	+ 140	0	5h4h	0	- 71	0	- 90	- 101
			—	—	—	—	—	5h6h	0	- 71	0	- 140	- 101
			—	—	—	—	—	6e	- 56	- 146	- 56	- 196	- 157
			—	—	—	—	—	6f	- 38	- 128	- 38	- 178	- 139
			6G	+ 140	+ 22	+ 202	+ 22	6g	- 22	- 112	- 22	- 162	- 123
			6H	+ 118	0	+ 180	0	6h	0	- 90	0	- 140	- 101
			—	—	—	—	—	7e6e	- 56	- 168	- 56	- 196	- 157
			7G	+ 172	+ 22	+ 246	+ 22	7g6g	- 22	- 134	- 22	- 162	- 123
			7H	+ 150	0	+ 224	0	7h6h	0	- 112	0	- 140	- 101
			8G	—	—	—	—	8g	—	—	—	—	—
			8H	—	—	—	—	9g8g	—	—	—	—	—
		0,75	—	—	—	—	—	3h4h	0	- 45	0	- 90	- 108
			4H	+ 75	0	+ 118	0	4h	0	- 56	0	- 90	- 108
			5G	+ 117	+ 22	+ 172	+ 22	5g6g	- 22	- 93	- 22	- 162	- 130
			5H	+ 95	0	+ 150	0	5h4h	0	- 71	0	- 90	- 108
			—	—	—	—	—	5h6h	0	- 71	0	- 140	- 108
			—	—	—	—	—	6e	- 56	- 146	- 56	- 196	- 164
			—	—	—	—	—	6f	- 38	- 128	- 38	- 178	- 146
			6G	+ 140	+ 22	+ 212	+ 22	6g	- 22	- 112	- 22	- 162	- 130
			6H	+ 118	0	+ 190	0	6h	0	- 90	0	- 140	- 108
			—	—	—	—	—	7e6e	- 56	- 168	- 56	- 196	- 164
			7G	+ 172	+ 22	+ 258	+ 22	7g6g	- 22	- 134	- 22	- 162	- 130
			7H	+ 150	0	+ 236	0	7h6h	0	- 112	0	- 140	- 108
		8G	—	—	—	—	8g	—	—	—	—	—	
		8H	—	—	—	—	9g8g	—	—	—	—	—	
		0,8	—	—	—	—	—	3h4h	0	- 48	0	- 95	- 115
			4H	+ 80	0	+ 125	0	4h	0	- 60	0	- 95	- 115
			5G	+ 124	+ 24	+ 184	+ 24	5g6g	- 24	- 99	- 24	- 174	- 140
			5H	+ 100	0	+ 160	0	5h4h	0	- 75	0	- 95	- 115
			—	—	—	—	—	5h6h	0	- 75	0	- 150	- 115
			—	—	—	—	—	6e	- 60	- 155	- 60	- 210	- 176
			—	—	—	—	—	6f	- 38	- 133	- 38	- 188	- 153
			6G	+ 149	+ 24	+ 224	+ 24	6g	- 24	- 119	- 24	- 174	- 140
			6H	+ 125	0	+ 200	0	6h	0	- 95	0	- 150	- 115
			—	—	—	—	—	7e6e	- 60	- 178	- 60	- 210	- 176
7G	+ 184		+ 24	+ 274	+ 24	7g6g	- 24	- 142	- 24	- 174	- 140		
7H	+ 160		0	+ 250	0	7h6h	0	- 118	0	- 150	- 116		



Table 14 — Deviations

*ES, es* = upper deviation  
*EI, ei* = lower deviation

Basic major diameter		Pitch	Nut thread				Bolt thread								
over	up to and incl.		Tolerance class	Pitch diameter		Minor diameter		Tolerance class	Pitch diameter		Major diameter		Minor diameter (for stress calculations)		
				<i>ES</i>	<i>EI</i>	<i>ES</i>	<i>EI</i>		<i>es</i>	<i>ei</i>	<i>es</i>	<i>ei</i>			
mm	mm	mm	$\mu\text{m}$	$\mu\text{m}$	$\mu\text{m}$	$\mu\text{m}$	$\mu\text{m}$	$\mu\text{m}$	$\mu\text{m}$	$\mu\text{m}$	$\mu\text{m}$	$\mu\text{m}$			
2,8	5,6	0,8	8G	+ 224	+ 24	+ 339	+ 24	8g	- 24	- 174	- 24	- 260	- 140		
			8H	+ 200	0	+ 315	0	9g8g	- 24	- 214	- 24	- 260	- 140		
5,6	11,2	0,75	—	—	—	—	—	3h4h	0	- 50	0	- 90	- 108		
			4H	+ 85	0	+ 118	0	4h	0	- 63	0	- 90	- 108		
			5G	+ 128	+ 22	+ 172	+ 22	5g6g	- 22	- 102	- 22	- 162	- 130		
			5H	+ 106	0	+ 150	0	5h4h	0	- 80	0	- 90	- 108		
			—	—	—	—	—	5h6h	0	- 80	0	- 140	- 108		
			—	—	—	—	—	6e	- 56	- 156	- 56	- 196	- 164		
			—	—	—	—	—	6f	- 38	- 138	- 38	- 178	- 146		
			6G	+ 154	+ 22	+ 212	+ 22	6g	- 22	- 122	- 22	- 162	- 130		
			6H	+ 132	0	+ 190	0	6h	0	- 100	0	- 140	- 108		
			—	—	—	—	—	7e6e	- 56	- 181	- 56	- 196	- 164		
			7G	+ 192	+ 22	+ 258	+ 22	7g6g	- 22	- 147	- 22	- 162	- 130		
			7H	+ 170	0	+ 236	0	7h6h	0	- 125	0	- 140	- 108		
		8G	—	—	—	—	8g	—	—	—	—	—			
		8H	—	—	—	—	9g8g	—	—	—	—	—			
		1	1	1	—	—	—	—	—	3h4h	0	- 56	0	- 112	- 144
					4H	+ 95	0	+ 150	0	4h	0	- 71	0	- 112	- 144
					5G	+ 144	+ 26	+ 216	+ 26	5g6g	- 26	- 116	- 26	- 206	- 170
					5H	+ 118	0	+ 190	0	5h4h	0	- 90	0	- 112	- 144
					—	—	—	—	—	5h6h	0	- 90	0	- 180	- 144
					—	—	—	—	—	6e	- 60	- 172	- 60	- 240	- 204
					—	—	—	—	—	6f	- 40	- 152	- 40	- 220	- 184
					6G	+ 176	+ 26	+ 262	+ 26	6g	- 26	- 138	- 26	- 206	- 170
6H	+ 150				0	+ 236	0	6h	0	- 112	0	- 180	- 144		
—	—				—	—	—	7e6e	- 60	- 200	- 60	- 240	- 204		
7G	+ 216				+ 26	+ 326	+ 26	7g6g	- 26	- 166	- 26	- 206	- 170		
7H	+ 190				0	+ 300	0	7h6h	0	- 140	0	- 180	- 144		
8G	+ 262	+ 26	+ 401	+ 26	8g	- 26	- 206	- 26	- 306	- 170					
8H	+ 236	0	+ 375	0	9g8g	- 26	- 250	- 26	- 306	- 170					
1,25	1,25	1,25	—	—	—	—	—	3h4h	0	- 60	0	- 132	- 180		
			4H	+ 100	0	+ 170	0	4h	0	- 75	0	- 132	- 180		
			5G	+ 153	+ 28	+ 240	+ 28	5g6g	- 28	- 123	- 28	- 240	- 208		
			5H	+ 125	0	+ 212	0	5h4h	0	- 95	0	- 132	- 180		
			—	—	—	—	—	5h6h	0	- 95	0	- 212	- 180		
			—	—	—	—	—	6e	- 63	- 181	- 63	- 275	- 243		
			—	—	—	—	—	6f	- 42	- 160	- 42	- 254	- 222		
			6G	+ 188	+ 28	+ 293	+ 28	6g	- 28	- 146	- 28	- 240	- 208		
			6H	+ 160	0	+ 265	0	6h	0	- 118	0	- 212	- 180		

Table 14 — Deviations

*ES, es* = upper deviation*EL, ei* = lower deviation

Basic major diameter		Pitch mm	Nut thread				Bolt thread						
over mm	up to and incl. mm		Tolerance class	Pitch diameter		Minor diameter		Tolerance class	Pitch diameter		Major diameter		Minor diameter (for stress calculations) µm
				<i>ES</i>	<i>EI</i>	<i>ES</i>	<i>EI</i>		<i>es</i>	<i>ei</i>	<i>es</i>	<i>ei</i>	
				µm	µm	µm	µm		µm	µm	µm	µm	
5,6	11,2	1,25	—	—	—	—	7e6e	-63	-213	-63	-275	-243	
			7G	+228	+28	+363	+28	7g6g	-28	-178	-28	-240	-208
			7H	+200	0	+335	0	7h6h	0	-150	0	-212	-180
			8G	+278	+28	+453	+28	8g	-28	-218	-28	-363	-208
			8H	+250	0	+425	0	9g8g	-28	-264	-28	-363	-208
		1,5	—	—	—	—	—	3h4h	0	-67	0	-150	-217
			4H	+112	0	+190	0	4h	0	-85	0	-150	-217
			5G	+172	+32	+268	+32	5g6g	-32	-138	-32	-268	-249
			5H	+140	0	+236	0	5h4h	0	-106	0	-150	-217
			—	—	—	—	—	5h6h	0	-106	0	-236	-217
			—	—	—	—	—	6e	-67	-199	-67	-303	-284
			—	—	—	—	—	6f	-45	-177	-45	-281	-262
			6G	+212	+32	+332	+32	6g	-32	-164	-32	-268	-249
			6H	+180	0	+300	0	6h	0	-132	0	-236	-217
			—	—	—	—	—	7e6e	-67	-237	-67	-303	-284
			7G	+256	+32	+407	+32	7g6g	-32	-202	-32	-268	-249
			7H	+224	0	+375	0	7h6h	0	-170	0	-236	-217
			8G	+312	+32	+507	+32	8g	-32	-244	-32	-407	-249
			8H	+280	0	+475	0	9g8g	-32	-297	-32	-407	-249
			11,2	22,4	1	—	—	—	—	3h4h	0	-60	0
4H	+100	0				+150	0	4h	0	-75	0	-112	-144
5G	+151	+26				+216	+26	5g6g	-26	-121	-26	-206	-170
5H	+125	0				+190	0	5h4h	0	-95	0	-112	-144
—	—	—				—	—	5h6h	0	-95	0	-180	-144
—	—	—				—	—	6e	-60	-178	-60	-240	-204
—	—	—				—	—	6f	-40	-158	-40	-220	-184
6G	+186	+26				+262	+26	6g	-26	-144	-26	-206	-170
6H	+160	0				+236	0	6h	0	-118	0	-180	-144
—	—	—				—	—	7e6e	-60	-210	-60	-240	-204
7G	+226	+26				+326	+26	7g6g	-26	-176	-26	-206	-170
7H	+200	0				+300	0	7h6h	0	-150	0	-180	-144
8G	+276	+26				+401	+26	8g	-26	-216	-26	-306	-170
8H	+250	0				+375	0	9g8g	-26	-262	-26	-306	-170
1,25	—	—				—	—	—	3h4h	0	-67	0	-132
	4H	+112			0	+170	0	4h	0	-85	0	-132	-180
	5G	+168			+28	+240	+28	5g6g	-28	-134	-28	-240	-208
	5H	+140			0	+212	0	5h4h	0	-106	0	-132	-180
	—	—			—	—	—	5h6h	0	-106	0	-212	-180
—	—	—			—	—	6e	-63	-195	-63	-275	-243	

Table 14 — Deviations

*ES, es* = upper deviation  
*EI, ei* = lower deviation

Basic major diameter		Pitch mm	Nut thread				Bolt thread						
over mm	up to and incl. mm		Tolerance class	Pitch diameter		Minor diameter		Tolerance class	Pitch diameter		Major diameter		Minor diameter (for stress calculations) µm
				<i>ES</i>	<i>EI</i>	<i>ES</i>	<i>EI</i>		<i>es</i>	<i>ei</i>	<i>es</i>	<i>ei</i>	
			µm	µm	µm	µm		µm	µm	µm	µm		
11,2	22,4	1,25	—	—	—	—	6f	-42	-174	-42	-254	-222	
			6G	+208	+28	+293	+28	6g	-28	-160	-28	-240	-208
			6H	+180	0	+265	0	6h	0	-132	0	-212	-180
			—	—	—	—	—	7e6e	-63	-233	-63	-275	-243
			7G	+252	+28	+363	+28	7g6g	-28	-198	-28	-240	-208
			7H	+224	0	+335	0	7h6h	0	-170	0	-212	-180
			8G	+308	+28	+453	+28	8g	-28	-240	-28	-363	-208
			8H	+280	0	+425	0	9g8g	-28	-293	-28	-363	-208
		1,5	—	—	—	—	—	3h4h	0	-71	0	-150	-217
			4H	+118	0	+190	0	4h	0	-90	0	-150	-217
			5G	+182	+32	+268	+32	5g6g	-32	-144	-32	-268	-249
			5H	+150	0	+236	0	5h4h	0	-112	0	-150	-217
			—	—	—	—	—	5h6h	0	-112	0	-236	-217
			—	—	—	—	—	6e	-67	-207	-67	-303	-284
			—	—	—	—	—	6f	-45	-185	-45	-281	-262
			6G	+222	+32	+332	+32	6g	-32	-172	-32	-268	-249
			6H	+190	0	+300	0	6h	0	-140	0	-236	-217
			—	—	—	—	—	7e6e	-67	-247	-67	-303	-284
			7G	+268	+32	+407	+32	7g6g	-32	-212	-32	-268	-249
			7H	+236	0	+375	0	7h6h	0	-180	0	-236	-217
			8G	+332	+32	+507	+32	8g	-32	-256	-32	-407	-249
			8H	+300	0	+475	0	9g8g	-32	-312	-32	-407	-249
		1,75	—	—	—	—	—	3h4h	0	-75	0	-170	-253
			4H	+125	0	+212	0	4h	0	-95	0	-170	-253
			5G	+194	+34	+299	+34	5g6g	-34	-152	-34	-299	-287
			5H	+160	0	+265	0	5h4h	0	-118	0	-170	-253
			—	—	—	—	—	5h6h	0	-118	0	-265	-253
			—	—	—	—	—	6e	-71	-221	-71	-336	-324
			—	—	—	—	—	6f	-48	-198	-48	-313	-301
			6G	+234	+34	+369	+34	6g	-34	-184	-34	-299	-287
			6H	+200	0	+335	0	6h	0	-150	0	-265	-253
			—	—	—	—	—	7e6e	-71	-261	-71	-336	-324
			7G	+284	+34	+459	+34	7g6g	-34	-224	-34	-299	-287
			7H	+250	0	+425	0	7h6h	0	-190	0	-265	-253
			8G	+349	+34	+564	+34	8g	-34	-270	-34	-459	-287
			8H	+315	0	+530	0	9g8g	-34	-334	-34	-459	-287
		2	—	—	—	—	—	3h4h	0	-80	0	-180	-289
			4H	+132	0	+236	0	4h	0	-100	0	-180	-289
			5G	+208	+38	+338	+38	5g6g	-38	-163	-38	-318	-327

Table 14 — Deviations

*ES, es* = upper deviation*EI, ei* = lower deviation

Basic major diameter		Pitch	Nut thread				Bolt thread						
over	up to and incl.		Tolerance class	Pitch diameter		Minor diameter		Tolerance class	Pitch diameter		Major diameter		Minor diameter (for stress calculations)
				<i>ES</i>	<i>EI</i>	<i>ES</i>	<i>EI</i>		<i>es</i>	<i>ei</i>	<i>es</i>	<i>ei</i>	
mm	mm			μm	μm	μm	μm		μm	μm	μm	μm	
11,2	22,4	2	5H	+ 170	0	+ 300	0	5h4h	0	- 125	0	- 180	- 289
			—	—	—	—	—	5h6h	0	- 125	0	- 280	- 289
			—	—	—	—	—	6e	- 71	- 231	- 71	- 351	- 360
			—	—	—	—	—	6f	- 52	- 212	- 52	- 332	- 341
			6G	+ 250	+ 38	+ 413	+ 38	6g	- 38	- 198	- 38	- 318	- 327
			6H	+ 212	0	+ 375	0	6h	0	- 160	0	- 280	- 289
			—	—	—	—	—	7e6e	- 71	- 271	- 71	- 351	- 360
			7G	+ 303	+ 38	+ 513	+ 38	7g6g	- 38	- 238	- 38	- 318	- 327
			7H	+ 265	0	+ 475	0	7h6h	0	- 200	0	- 280	- 289
			8G	+ 373	+ 38	+ 638	+ 38	8g	- 38	- 288	- 38	- 488	- 327
		8H	+ 335	0	+ 600	0	9g8g	- 38	- 353	- 38	- 488	- 327	
		2,5	—	—	—	—	—	3h4h	0	- 85	0	- 212	- 361
			4H	+ 140	0	+ 280	0	4h	0	- 106	0	- 212	- 361
			5G	+ 222	+ 42	+ 397	+ 42	5g6g	- 42	- 174	- 42	- 377	- 403
			5H	+ 180	0	+ 355	0	5h4h	0	- 132	0	- 212	- 361
			—	—	—	—	—	5h6h	0	- 132	0	- 335	- 361
			—	—	—	—	—	6e	- 80	- 250	- 80	- 415	- 441
			—	—	—	—	—	6f	- 58	- 228	- 58	- 393	- 419
			6G	+ 266	+ 42	+ 492	+ 42	6g	- 42	- 212	- 42	- 377	- 403
			6H	+ 224	0	+ 450	0	6h	0	- 170	0	- 335	- 361
—	—		—	—	—	7e6e	- 80	- 292	- 80	- 415	- 441		
7G	+ 322	+ 42	+ 602	+ 42	7g6g	- 42	- 254	- 42	- 377	- 403			
7H	+ 280	0	+ 560	0	7h6h	0	- 212	0	- 335	- 361			
8G	+ 397	+ 42	+ 752	+ 42	8g	- 42	- 307	- 42	- 572	- 403			
8H	+ 355	0	+ 710	0	9g8g	- 42	- 377	- 42	- 572	- 403			
22,4	45	1	—	—	—	—	—	3h4h	0	- 63	0	- 112	- 144
			4H	+ 106	0	+ 150	0	4h	0	- 80	0	- 112	- 144
			5G	+ 158	+ 26	+ 216	+ 26	5g6g	- 26	- 126	- 26	- 206	- 170
			5H	+ 132	0	+ 190	0	5h4h	0	- 100	0	- 112	- 144
			—	—	—	—	—	5h6h	0	- 100	0	- 180	- 144
			—	—	—	—	—	6e	- 60	- 185	- 60	- 240	- 204
			—	—	—	—	—	6f	- 40	- 165	- 40	- 220	- 184
			6G	+ 196	+ 26	+ 262	+ 26	6g	- 26	- 151	- 26	- 206	- 170
			6H	+ 170	0	+ 236	0	6h	0	- 125	0	- 180	- 144
			—	—	—	—	—	7e6e	- 60	- 220	- 60	- 240	- 204
			7G	+ 238	+ 26	+ 326	+ 26	7g6g	- 26	- 186	- 26	- 206	- 170
			7H	+ 212	0	+ 300	0	7h6h	0	- 160	0	- 180	- 144
			8G	—	—	—	—	8g	- 26	- 226	- 26	- 306	- 170
			8H	—	—	—	—	9g8g	- 26	- 276	- 26	- 306	- 170

Table 14 — Deviations

*ES, es* = upper deviation  
*EI, ei* = lower deviation

Basic major diameter		Pitch	Nut thread				Bolt thread							
over	up to and incl.		Tolerance class	Pitch diameter		Minor diameter		Tolerance class	Pitch diameter		Major diameter		Minor diameter (for stress calculations)	
				<i>ES</i>	<i>EI</i>	<i>ES</i>	<i>EI</i>		<i>es</i>	<i>ei</i>	<i>es</i>	<i>ei</i>		
mm	mm	mm	$\mu\text{m}$	$\mu\text{m}$	$\mu\text{m}$	$\mu\text{m}$	$\mu\text{m}$	$\mu\text{m}$	$\mu\text{m}$	$\mu\text{m}$	$\mu\text{m}$	$\mu\text{m}$		
22,4	45	1,5	—	—	—	—	3h4h	0	-75	0	-150	-217		
			4H	+125	0	+190	0	4h	0	-95	0	-150	-217	
			5G	+192	+32	+268	+32	5g6g	-32	-150	-32	-268	-249	
			5H	+160	0	+236	0	5h4h	0	-118	0	-150	-217	
			—	—	—	—	—	5h6h	0	-118	0	-236	-217	
			—	—	—	—	—	6e	-67	-217	-67	-303	-284	
			—	—	—	—	—	6f	-45	-195	-45	-281	-262	
			6G	+232	+32	+332	+32	6g	-32	-182	-32	-268	-249	
			6H	+200	0	+300	0	6h	0	-150	0	-236	-217	
			—	—	—	—	—	7e6e	-67	-257	-67	-303	-284	
			7G	+282	+32	+407	+32	7g6g	-32	-222	-32	-268	-249	
			7H	+250	0	+375	0	7h6h	0	-190	0	-236	-217	
		8G	+347	+32	+507	+32	8g	-32	-268	-32	-407	-249		
		8H	+315	0	+475	0	9g8g	-32	-332	-32	-407	-249		
		—	—	2	—	—	—	—	3h4h	0	-85	0	-180	-289
		4H	+140		0	+236	0	4h	0	-106	0	-180	-289	
		5G	+218		+38	+338	+38	5g6g	-38	-170	-38	-318	-327	
		5H	+180		0	+300	0	5h4h	0	-132	0	-180	-289	
		—	—		—	—	—	5h6h	0	-132	0	-280	-289	
		—	—		—	—	—	6e	-71	-241	-71	-351	-360	
		—	—		—	—	—	6f	-52	-222	-52	-332	-341	
		6G	+262		+38	+413	+38	6g	-38	-208	-38	-318	-327	
		6H	+224		0	+375	0	6h	0	-170	0	-280	-289	
		—	—		—	—	—	7e6e	-71	-283	-71	-351	-360	
		7G	+318		+38	+513	+38	7g6g	-38	-250	-38	-318	-327	
		7H	+280		0	+475	0	7h6h	0	-212	0	-280	-289	
		8G	+393	+38	+638	+38	8g	-38	-303	-38	-488	-327		
		8H	+355	0	+600	0	9g8g	-38	-373	-38	-488	-327		
		—	—	3	—	—	—	—	3h4h	0	-100	0	-236	-433
		4H	+170		0	+315	0	4h	0	-125	0	-236	-433	
		5G	+260		+48	+448	+48	5g6g	-48	-208	-48	-423	-481	
		5H	+212		0	+400	0	5h4h	0	-160	0	-236	-433	
		—	—		—	—	—	5h6h	0	-160	0	-375	-433	
		—	—		—	—	—	6e	-85	-285	-85	-460	-518	
		—	—		—	—	—	6f	-63	-263	-63	-438	-496	
		6G	+313		+48	+548	+48	6g	-48	-248	-48	-423	-481	
6H	+265	0	+500		0	6h	0	-200	0	-375	-433			
—	—	—	—		—	7e6e	-85	-335	-85	-460	-518			
7G	+383	+48	+678		+48	7g6g	-48	-298	-48	-423	-481			

Table 14 — Deviations

*ES, es* = upper deviation*EI, ei* = lower deviation

Basic major diameter		Pitch	Nut thread					Bolt thread						
over	up to and incl.		Tolerance class	Pitch diameter		Minor diameter		Tolerance class	Pitch diameter		Major diameter		Minor diameter (for stress calculations)	
				<i>ES</i>	<i>EI</i>	<i>ES</i>	<i>EI</i>		<i>es</i>	<i>ei</i>	<i>es</i>	<i>ei</i>		
mm	mm		mm	μm	μm	μm	μm	μm	μm	μm	μm	μm		
22,4	45	3	7H	+ 335	0	+ 630	0	7h6h	0	- 250	0	- 375	- 433	
			8G	+ 473	+ 48	+ 848	+ 48	8g	- 48	- 363	- 48	- 648	- 481	
			8H	+ 425	0	+ 800	0	9g8g	- 48	- 448	- 48	- 648	- 481	
		3,5	—	—	—	—	—	—	3h4h	0	- 106	0	- 265	- 505
			4H	+ 180	0	+ 355	0	4h	0	- 132	0	- 265	- 505	
			5G	+ 277	+ 53	+ 503	+ 53	5g6g	- 53	- 223	- 53	- 478	- 558	
			5H	+ 224	0	+ 450	0	5h4h	0	- 170	0	- 265	- 505	
			—	—	—	—	—	—	5h6h	0	- 170	0	- 425	- 505
			—	—	—	—	—	—	6e	- 90	- 302	- 90	- 515	- 595
			—	—	—	—	—	—	6f	- 70	- 282	- 70	- 495	- 575
			6G	+ 333	+ 53	+ 613	+ 53	6g	- 53	- 265	- 53	- 478	- 558	
			6H	+ 280	0	+ 560	0	6h	0	- 212	0	- 425	- 505	
			—	—	—	—	—	—	7e6e	- 90	- 355	- 90	- 515	- 595
			7G	+ 408	+ 53	+ 763	+ 53	7g6g	- 53	- 318	- 53	- 478	- 558	
			7H	+ 355	0	+ 710	0	7h6h	0	- 265	0	- 425	- 505	
			8G	+ 503	+ 53	+ 953	+ 53	8g	- 53	- 388	- 53	- 723	- 558	
			8H	+ 450	0	+ 900	0	9g8g	- 53	- 478	- 53	- 723	- 558	
			4	—	—	—	—	—	—	3h4h	0	- 112	0	- 300
		4H		+ 190	0	+ 375	0	4h	0	- 140	0	- 300	- 577	
		5G		+ 296	+ 60	+ 535	+ 60	5g6g	- 60	- 240	- 60	- 535	- 637	
		5H		+ 236	0	+ 475	0	5h4h	0	- 180	0	- 300	- 577	
		—		—	—	—	—	—	5h6h	0	- 180	0	- 475	- 577
		—		—	—	—	—	—	6e	- 95	- 319	- 95	- 570	- 672
		—		—	—	—	—	—	6f	- 75	- 299	- 75	- 550	- 652
		6G		+ 360	+ 60	+ 660	+ 60	6g	- 60	- 284	- 60	- 535	- 637	
		6H		+ 300	0	+ 600	0	6h	0	- 224	0	- 475	- 577	
		—		—	—	—	—	—	7e6e	- 95	- 375	- 95	- 570	- 672
		7G		+ 435	+ 60	+ 810	+ 60	7g6g	- 60	- 340	- 60	- 535	- 637	
		7H		+ 375	0	+ 750	0	7h6h	0	- 280	0	- 475	- 577	
		8G	+ 535	+ 60	+ 1 010	+ 60	8g	- 60	- 415	- 60	- 810	- 637		
		8H	+475	0	+ 950	0	9g8g	- 60	- 510	- 60	- 810	- 637		
		4,5	—	—	—	—	—	—	3h4h	0	- 118	0	- 315	- 650
			4H	+ 200	0	+ 425	0	4h	0	- 150	0	- 315	- 650	
5G	+ 313		+ 63	+ 593	+ 63	5g6g	- 63	- 253	- 63	- 563	- 713			
5H	+ 250		0	+ 530	0	5h4h	0	- 190	0	- 315	- 650			
—	—		—	—	—	—	5h6h	0	- 190	0	- 500	- 650		
—	—		—	—	—	—	6e	- 100	- 336	- 100	- 600	- 750		
—	—		—	—	—	—	6f	- 80	- 316	- 80	- 580	- 730		
6G	+ 378		+ 63	+ 733	+ 63	6g	- 63	- 299	- 63	- 563	- 713			

Table 14 — Deviations

*ES, es* = upper deviation  
*EI, ei* = lower deviation

Basic major diameter		Pitch mm	Nut thread					Bolt thread							
over mm	up to and incl. mm		Tolerance class	Pitch diameter		Minor diameter		Tolerance class	Pitch diameter		Major diameter		Minor diameter (for stress calculations) µm		
				<i>ES</i>	<i>EI</i>	<i>ES</i>	<i>EI</i>		<i>es</i>	<i>ei</i>	<i>es</i>	<i>ei</i>			
µm	µm			µm	µm	µm	µm		µm	µm	µm	µm			
22,4	45	4,5	6H	+ 315	0	+ 670	0	6h	0	- 236	0	- 500	- 650		
			—	—	—	—	—	7e6e	- 100	- 400	- 100	- 600	- 750		
			7G	+ 463	+ 63	+ 913	+ 63	7g6g	- 63	- 363	- 63	- 563	- 713		
			7H	+ 400	0	+ 850	0	7h6h	0	- 300	0	- 500	- 650		
			8G	+ 563	+ 63	+ 1 123	+ 63	8g	- 63	- 438	- 63	- 863	- 713		
			8H	+ 500	0	+ 1 060	0	9g8g	- 63	- 538	- 63	- 863	- 713		
45	90	1,5	—	—	—	—	—	3h4h	0	- 80	0	- 150	- 217		
			4H	+ 132	0	+ 190	0	4h	0	- 100	0	- 150	- 217		
			5G	+ 202	+ 32	+ 268	+ 32	5g6g	- 32	- 157	- 32	- 268	- 249		
			5H	+ 170	0	+ 236	0	5h4h	0	- 125	0	- 150	- 217		
			—	—	—	—	—	5h6h	0	- 125	0	- 236	- 217		
			—	—	—	—	—	6e	- 67	- 227	- 67	- 303	- 284		
			—	—	—	—	—	6f	- 45	- 205	- 45	- 281	- 262		
			6G	+ 244	+ 32	+ 332	+ 32	6g	- 32	- 192	- 32	- 268	- 249		
			6H	+ 212	0	+ 300	0	6h	0	- 160	0	- 236	- 217		
			—	—	—	—	—	7e6e	- 67	- 267	- 67	- 303	- 284		
			7G	+ 297	+ 32	+ 407	+ 32	7g6g	- 32	- 232	- 32	- 268	- 249		
			7H	+ 265	0	+ 375	0	7h6h	0	- 200	0	- 236	- 217		
			8G	+ 367	+ 32	+ 507	+ 32	8g	- 32	- 282	- 32	- 407	- 249		
			8H	+ 335	0	+ 475	0	9g8g	- 32	- 347	- 32	- 407	- 249		
		2	—	—	—	—	—	—	3h4h	0	- 90	0	- 180	- 289	
			4H	+ 150	0	+ 236	0	4h	0	- 112	0	- 180	- 289		
			5G	+ 228	+ 38	+ 338	+ 38	5g6g	- 38	- 178	- 38	- 318	- 327		
			5H	+ 190	0	+ 300	0	5h4h	0	- 140	0	- 180	- 289		
			—	—	—	—	—	5h6h	0	- 140	0	- 280	- 289		
			—	—	—	—	—	6e	- 71	- 251	- 71	- 351	- 360		
			—	—	—	—	—	6f	- 52	- 232	- 52	- 332	- 341		
			6G	+ 274	+ 38	+ 413	+ 38	6g	- 38	- 218	- 38	- 318	- 327		
			6H	+ 236	0	+ 375	0	6h	0	- 180	0	- 280	- 289		
			—	—	—	—	—	7e6e	- 71	- 295	- 71	- 351	- 360		
			7G	+ 338	+ 38	+ 513	+ 38	7g6g	- 38	- 262	- 38	- 318	- 327		
			7H	+ 300	0	+ 475	0	7h6h	0	- 224	0	- 280	- 289		
			8G	+ 413	+ 38	+ 638	+ 38	8g	- 38	- 318	- 38	- 488	- 327		
			8H	+ 375	0	+ 600	0	9g8g	- 38	- 393	- 38	- 488	- 327		
			3	—	—	—	—	—	—	3h4h	0	- 106	0	- 236	- 433
				4H	+ 180	0	+ 315	0	4h	0	- 132	0	- 236	- 433	
5G	+ 272	+ 48		+ 448	+ 48	5g6g	- 48	- 218	- 48	- 423	- 481				
5H	+ 224	0		+ 400	0	5h4h	0	- 170	0	- 236	- 433				
—	—	—		—	—	5h6h	0	- 170	0	- 375	- 433				

Table 14 — Deviations

*ES, es* = upper deviation*EI, ei* = lower deviation

Basic major diameter		Pitch mm	Nut thread				Bolt thread						
over mm	up to and incl. mm		Tolerance class	Pitch diameter		Minor diameter		Tolerance class	Pitch diameter		Major diameter		Minor diameter (for stress calculations) µm
				<i>ES</i>	<i>EI</i>	<i>ES</i>	<i>EI</i>		<i>es</i>	<i>ei</i>	<i>es</i>	<i>ei</i>	
				µm	µm	µm	µm		µm	µm	µm	µm	
45	90	3	—	—	—	—	6e	-85	-297	-85	-460	-518	
			—	—	—	—	6f	-63	-275	-63	-438	-496	
			6G	+328	+48	+548	+48	6g	-48	-260	-48	-423	-481
			6H	+280	0	+500	0	6h	0	-212	0	-375	-433
			—	—	—	—	7e6e	-85	-350	-85	-460	-518	
			7G	+403	+48	+678	+48	7g6g	-48	-313	-48	-423	-481
			7H	+355	0	+630	0	7h6h	0	-265	0	-375	-433
			8G	+498	+48	+848	+48	8g	-48	-383	-48	-648	-481
			8H	+450	0	+800	0	9g8g	-48	-473	-48	-648	-481
		4	—	—	—	—	—	3h4h	0	-118	0	-300	-577
			4H	+200	0	+375	0	4h	0	-150	0	-300	-577
			5G	+310	+60	+535	+60	5g6g	-60	-250	-60	-535	-637
			5H	+250	0	+475	0	5h4h	0	-190	0	-300	-577
			—	—	—	—	—	5h6h	0	-190	0	-475	-577
			—	—	—	—	—	6e	-95	-331	-95	-570	-672
			—	—	—	—	—	6f	-75	-311	-75	-550	-652
			6G	+375	+60	+660	+60	6g	-60	-296	-60	-535	-637
			6H	+315	0	+600	0	6h	0	-236	0	-475	-577
			—	—	—	—	—	7e6e	-95	-395	-95	-570	-672
			7G	+460	+60	+810	+60	7g6g	-60	-360	-60	-535	-637
			7H	+400	0	+750	0	7h6h	0	-300	0	-475	-577
			8G	+560	+60	+1 010	+60	8g	-60	-435	-60	-810	-637
			8H	+500	0	+950	0	9g8g	-60	-535	-60	-810	-637
			5	—	—	—	—	—	3h4h	0	-125	0	-335
		4H		+212	0	+450	0	4h	0	-160	0	-335	-722
		5G		+336	+71	+631	+71	5g6g	-71	-271	-71	-601	-793
		5H		+265	0	+560	0	5h4h	0	-200	0	-335	-722
		—		—	—	—	—	5h6h	0	-200	0	-530	-722
		—		—	—	—	—	6e	-106	-356	-106	-636	-828
		—		—	—	—	—	6f	-85	-335	-85	-615	-807
		6G		+406	+71	+781	+71	6g	-71	-321	-71	-601	-793
		6H		+335	0	+710	0	6h	0	-250	0	-530	-722
		—		—	—	—	—	7e6e	-106	-421	-106	-636	-828
		7G		+496	+71	+971	+71	7g6g	-71	-386	-71	-601	-793
		7H		+425	0	+900	0	7h6h	0	-315	0	-530	-722
		8G		+601	+71	+1 191	+71	8g	-71	-471	-71	-921	-793
8H	+530	0		+1 120	0	9g8g	-71	-571	-71	-921	-793		
5,5	—	—		—	—	—	3h4h	0	-132	0	-355	-794	
	4H	+224	0	+475	0	4h	0	-170	0	-355	-794		



Table 14 — Deviations

*ES, es* = upper deviation  
*EI, ei* = lower deviation

Basic major diameter		Pitch mm	Nut thread					Bolt thread					
over mm	up to and incl. mm		Tolerance class	Pitch diameter		Minor diameter		Tolerance class	Pitch diameter		Major diameter		Minor diameter (for stress calculations) µm
				<i>ES</i>	<i>EI</i>	<i>ES</i>	<i>EI</i>		<i>es</i>	<i>ei</i>	<i>es</i>	<i>ei</i>	
µm	µm			µm	µm	µm	µm		µm	µm	µm	µm	
45	90	5,5	5G	+ 355	+ 75	+ 675	+ 75	5g6g	- 75	- 287	- 75	- 635	- 869
			5H	+ 280	0	+ 600	0	5h4h	0	- 212	0	- 355	- 794
			—	—	—	—	—	5h6h	0	- 212	0	- 560	- 794
			—	—	—	—	—	6e	- 112	- 377	- 112	- 672	- 906
			—	—	—	—	—	6f	- 90	- 355	- 90	- 650	- 884
			6G	+ 430	+ 75	+ 825	+ 75	6g	- 75	- 340	- 75	- 635	- 869
			6H	+ 355	0	+ 750	0	6h	0	- 265	0	- 560	- 794
			—	—	—	—	—	7e6e	- 112	- 447	- 112	- 672	- 906
			7G	+ 525	+ 75	+ 1 025	+ 75	7g6g	- 75	- 410	- 75	- 635	- 869
			7H	+ 450	0	+ 950	0	7h6h	0	- 335	0	- 560	- 794
		8G	+ 635	+ 75	+ 1 255	+ 75	8g	- 75	- 500	- 75	- 975	- 869	
		8H	+ 560	0	+ 1 180	0	9g8g	- 75	- 605	- 75	- 975	- 869	
		6	—	—	—	—	—	3h4h	0	- 140	0	- 375	- 866
			4H	+ 236	0	+ 500	0	4h	0	- 180	0	- 375	- 866
			5G	+ 380	+ 80	+ 710	+ 80	5g6g	- 80	- 304	- 80	- 680	- 946
			5H	+ 300	0	+ 630	0	5h4h	0	- 224	0	- 375	- 866
			—	—	—	—	—	5h6h	0	- 224	0	- 600	- 866
			—	—	—	—	—	6e	- 118	- 398	- 118	- 718	- 984
			—	—	—	—	—	6f	- 95	- 375	- 95	- 695	- 961
			6G	+ 455	+ 80	+ 880	+ 80	6g	- 80	- 360	- 80	- 680	- 946
6H	+ 375		0	+ 800	0	6h	0	- 280	0	- 600	- 866		
—	—		—	—	—	7e6e	- 118	- 473	- 118	- 718	- 984		
90	180	2	—	—	—	—	3h4h	0	- 95	0	- 180	- 289	
			4H	+ 160	0	+ 236	0	4h	0	- 118	0	- 180	- 289
			5G	+ 238	+ 38	+ 338	+ 38	5g6g	- 38	- 188	- 38	- 318	- 327
			5H	+ 200	0	+ 300	0	5h4h	0	- 150	0	- 180	- 289
			—	—	—	—	—	5h6h	0	- 150	0	- 280	- 289
			—	—	—	—	—	6e	- 71	- 261	- 71	- 351	- 360
			—	—	—	—	—	6f	- 52	- 242	- 52	- 332	- 341
			6G	+ 288	+ 38	+ 413	+ 38	6g	- 38	- 228	- 38	- 318	- 327
			6H	+ 250	0	+ 375	0	6h	0	- 190	0	- 280	- 289
			—	—	—	—	—	7e6e	- 71	- 307	- 71	- 351	- 360
			7G	+ 353	+ 38	+ 513	+ 38	7g6g	- 38	- 274	- 38	- 318	- 327
			7H	+ 315	0	+ 475	0	7h6h	0	- 236	0	- 280	- 289
8G	+ 438	+ 38	+ 638	+ 38	8g	- 38	- 338	- 38	- 488	- 327			

Table 14 — Deviations

*ES, es* = upper deviation*EI, ei* = lower deviation

Basic major diameter		Pitch	Nut thread					Bolt thread					
over	up to and incl.		Tolerance class	Pitch diameter		Minor diameter		Tolerance class	Pitch diameter		Major diameter		Minor diameter (for stress calculations)
				<i>ES</i>	<i>EI</i>	<i>ES</i>	<i>EI</i>		<i>es</i>	<i>ei</i>	<i>es</i>	<i>ei</i>	
				$\mu\text{m}$	$\mu\text{m}$	$\mu\text{m}$	$\mu\text{m}$		$\mu\text{m}$	$\mu\text{m}$	$\mu\text{m}$	$\mu\text{m}$	
90	180	2	8H	+ 400	0	+ 600	0	9g8g	- 38	- 413	- 38	- 488	- 327
		3	—	—	—	—	—	3h4h	0	- 112	0	- 236	- 433
			4H	+ 190	0	+ 315	0	4h	0	- 140	0	- 236	- 433
			5G	+ 284	+ 48	+ 448	+ 48	5g6g	- 48	- 228	- 48	- 423	- 481
			5H	+ 236	0	+ 400	0	5h4h	0	- 180	0	- 236	- 433
			—	—	—	—	—	5h6h	0	- 180	0	- 375	- 433
			—	—	—	—	—	6e	- 85	- 309	- 85	- 460	- 518
			—	—	—	—	—	6f	- 63	- 287	- 63	- 438	- 496
			6G	+ 348	+ 48	+ 548	+ 48	6g	- 48	- 272	- 48	- 423	- 481
			6H	+ 300	0	+ 500	0	6h	0	- 224	0	- 375	- 433
			—	—	—	—	—	7e6e	- 85	- 365	- 85	- 460	- 518
			7G	+ 423	+ 48	+ 678	+ 48	7g6g	- 48	- 328	- 48	- 423	- 481
			7H	+ 375	0	+ 630	0	7h6h	0	- 280	0	- 375	- 433
			8G	+ 523	+ 48	+ 848	+ 48	8g	- 48	- 403	- 48	- 648	- 481
		8H	+ 475	0	+ 800	0	9g8g	- 48	- 498	- 48	- 648	- 481	
		4	—	—	—	—	—	3h4h	0	- 125	0	- 300	- 577
			4H	+ 212	0	+ 375	0	4h	0	- 160	0	- 300	- 577
			5G	+ 325	+ 60	+ 535	+ 60	5g6g	- 60	- 260	- 60	- 535	- 637
			5H	+ 265	0	+ 475	0	5h4h	0	- 200	0	- 300	- 577
			—	—	—	—	—	5h6h	0	- 200	0	- 475	- 577
			—	—	—	—	—	6e	- 95	- 345	- 95	- 570	- 672
			—	—	—	—	—	6f	- 75	- 325	- 75	- 550	- 652
			6G	+ 395	+ 60	+ 660	+ 60	6g	- 60	- 310	- 60	- 535	- 637
			6H	+ 335	0	+ 600	0	6h	0	- 250	0	- 475	- 577
			—	—	—	—	—	7e6e	- 95	- 410	- 95	- 570	- 672
			7G	+ 485	+ 60	+ 810	+ 60	7g6g	- 60	- 375	- 60	- 535	- 637
			7H	+ 425	0	+ 750	0	7h6h	0	- 315	0	- 475	- 577
			8G	+ 590	+ 60	+ 1 010	+ 60	8g	- 60	- 460	- 60	- 810	- 637
		8H	+ 530	0	+ 950	0	9g8g	- 60	- 560	- 60	- 810	- 637	
		6	—	—	—	—	—	3h4h	0	- 150	0	- 375	- 866
			4H	+ 250	0	+ 500	0	4h	0	- 190	0	- 375	- 866
			5G	+ 395	+ 80	+ 710	+ 80	5g6g	- 80	- 316	- 80	- 680	- 946
			5H	+ 315	0	+ 630	0	5h4h	0	- 236	0	- 375	- 866
			—	—	—	—	—	5h6h	0	- 236	0	- 600	- 866
			—	—	—	—	—	6e	- 118	- 418	- 118	- 718	- 984
			—	—	—	—	—	6f	- 95	- 395	- 95	- 695	- 961
			6G	+ 480	+ 80	+ 880	+ 80	6g	- 80	- 380	- 80	- 680	- 946
			6H	+ 400	0	+ 800	0	6h	0	- 300	0	- 600	- 866
			—	—	—	—	—	7e6e	- 118	- 493	- 118	- 718	- 984

Table 14 — Deviations

*ES, es* = upper deviation  
*EI, ei* = lower deviation

Basic major diameter		Pitch mm	Nut thread					Bolt thread						
over mm	up to and incl. mm		Tolerance class	Pitch diameter		Minor diameter		Tolerance class	Pitch diameter		Major diameter		Minor diameter (for stress calculations) µm	
				<i>ES</i>	<i>EI</i>	<i>ES</i>	<i>EI</i>		<i>es</i>	<i>ei</i>	<i>es</i>	<i>ei</i>		
µm	µm			µm	µm	µm	µm		µm	µm	µm	µm		
90	180	6	7G	+ 580	+ 80	+ 1 080	+ 80	7g6g	- 80	- 455	- 80	- 680	- 946	
			7H	+ 500	0	+ 1 000	0	7h6h	0	- 375	0	- 600	- 866	
			8G	+ 710	+ 80	+ 1 330	+ 80	8g	- 80	- 555	- 80	- 1 030	- 946	
			8H	+ 630	0	+ 1 250	0	9g8g	- 80	- 680	- 80	- 1 030	- 946	
180	300	3	—	—	—	—	—	3h4h	0	- 125	0	- 236	- 433	
			4H	+ 212	0	+ 315	0	4h	0	- 160	0	- 236	- 433	
			5G	+ 313	+ 48	+ 448	+ 48	5g6g	- 48	- 248	- 48	- 423	- 481	
			5H	+ 265	0	+ 400	0	5h4h	0	- 200	0	- 236	- 433	
			—	—	—	—	—	5h6h	0	- 200	0	- 375	- 433	
			—	—	—	—	—	6e	- 85	- 335	- 85	- 460	- 518	
			—	—	—	—	—	6f	- 63	- 313	- 63	- 438	- 496	
			6G	+ 383	+ 48	+ 548	+ 48	6g	- 48	- 298	- 48	- 423	- 481	
			6H	+ 335	0	+ 500	0	6h	0	- 250	0	- 375	- 433	
			—	—	—	—	—	7e6e	- 85	- 400	- 85	- 460	- 518	
			7G	+ 473	+ 48	+ 678	+ 48	7g6g	- 48	- 363	- 48	- 423	- 481	
			7H	+ 425	0	+ 630	0	7h6h	0	- 315	0	- 375	- 433	
			8G	+ 578	+ 48	+ 848	+ 48	8g	- 48	- 448	- 48	- 648	- 481	
			8H	+ 530	0	+ 800	0	9g8g	- 48	- 548	- 48	- 648	- 481	
		4	—	—	—	—	—	—	3h4h	0	- 140	0	- 300	- 577
			4H	+ 236	0	+ 375	0	4h	0	- 180	0	- 300	- 577	
			5G	+ 360	+ 60	+ 535	+ 60	5g6g	- 60	- 284	- 60	- 535	- 637	
			5H	+ 300	0	+ 475	0	5h4h	0	- 224	0	- 300	- 577	
			—	—	—	—	—	5h6h	0	- 224	0	- 475	- 577	
			—	—	—	—	—	6e	- 95	- 375	- 95	- 570	- 672	
			—	—	—	—	—	6f	- 75	- 355	- 75	- 550	- 652	
			6G	+ 435	+ 60	+ 660	+ 60	6g	- 60	- 340	- 60	- 535	- 637	
			6H	+ 375	0	+ 600	0	6h	0	- 280	0	- 475	- 577	
			—	—	—	—	—	7e6e	- 95	- 450	- 95	- 570	- 672	
			7G	+ 535	+ 60	+ 810	+ 60	7g6g	- 60	- 415	- 60	- 535	- 637	
			7H	+ 475	0	+ 750	0	7h6h	0	- 355	0	- 475	- 577	
			8G	+ 660	+ 60	+ 1 010	+ 60	8g	- 60	- 510	- 60	- 810	- 637	
			8H	+ 600	0	+ 950	0	9g8g	- 60	- 620	- 60	- 810	- 637	
6	—	—	—	—	—	—	3h4h	0	- 160	0	- 375	- 866		
	4H	+ 265	0	+ 500	0	4h	0	- 200	0	- 375	- 866			
	5G	+ 415	+ 80	+ 710	+ 80	5g6g	- 80	- 330	- 80	- 680	- 946			
	5H	+ 335	0	+ 630	0	5h4h	0	- 250	0	- 375	- 866			
	—	—	—	—	—	5h6h	0	- 250	0	- 600	- 866			
	—	—	—	—	—	6e	- 118	- 433	- 118	- 718	- 984			
	—	—	—	—	—	6f	- 95	- 410	- 95	- 695	- 961			

Table 14 — Deviations

*ES, es* = upper deviation*EI, ei* = lower deviation

Basic major diameter		Pitch mm	Nut thread					Bolt thread					
over mm	up to and incl. mm		Tolerance class	Pitch diameter		Minor diameter		Tolerance class	Pitch diameter		Major diameter		Minor diameter (for stress calculations) µm
				<i>ES</i>	<i>EI</i>	<i>ES</i>	<i>EI</i>		<i>es</i>	<i>ei</i>	<i>es</i>	<i>ei</i>	
µm	µm			µm	µm	µm	µm		µm	µm	µm	µm	
180	300	6	6G	+ 505	+ 80	+ 880	+ 80	6g	- 80	- 395	- 80	- 680	- 946
			6H	+ 425	0	+ 800	0	6h	0	- 315	0	- 600	- 866
			—	—	—	—	—	7e6e	- 118	- 518	- 118	- 718	- 984
			7G	+ 610	+ 80	+ 1 080	+ 80	7g6g	- 80	- 480	- 80	- 680	- 946
			7H	+ 530	0	+ 1 000	0	7h6h	0	- 400	0	- 600	- 866
			8G	+ 750	+ 80	+ 1 330	+ 80	8g	- 80	- 580	- 80	- 1 030	- 946
			8H	+ 670	0	+ 1 250	0	9g8g	- 80	- 710	- 80	- 1 030	- 946

## Appendix A Notes for guidance

**A.1 Maximum material profile.** The maximum material profile of the thread for a nut and for a bolt is shown in Figure 9. These profiles are established from the basic profile given in clause 3.

**A.2 Coating.** Clause 6 gives information on tolerance position G, e, f and g, which provide clearance fits which may be used to accommodate coatings.

BS ....<sup>2)</sup>, which is in course of preparation, will include tables listing pitches and tolerance positions and the maximum thickness of coating that can be accommodated by each.

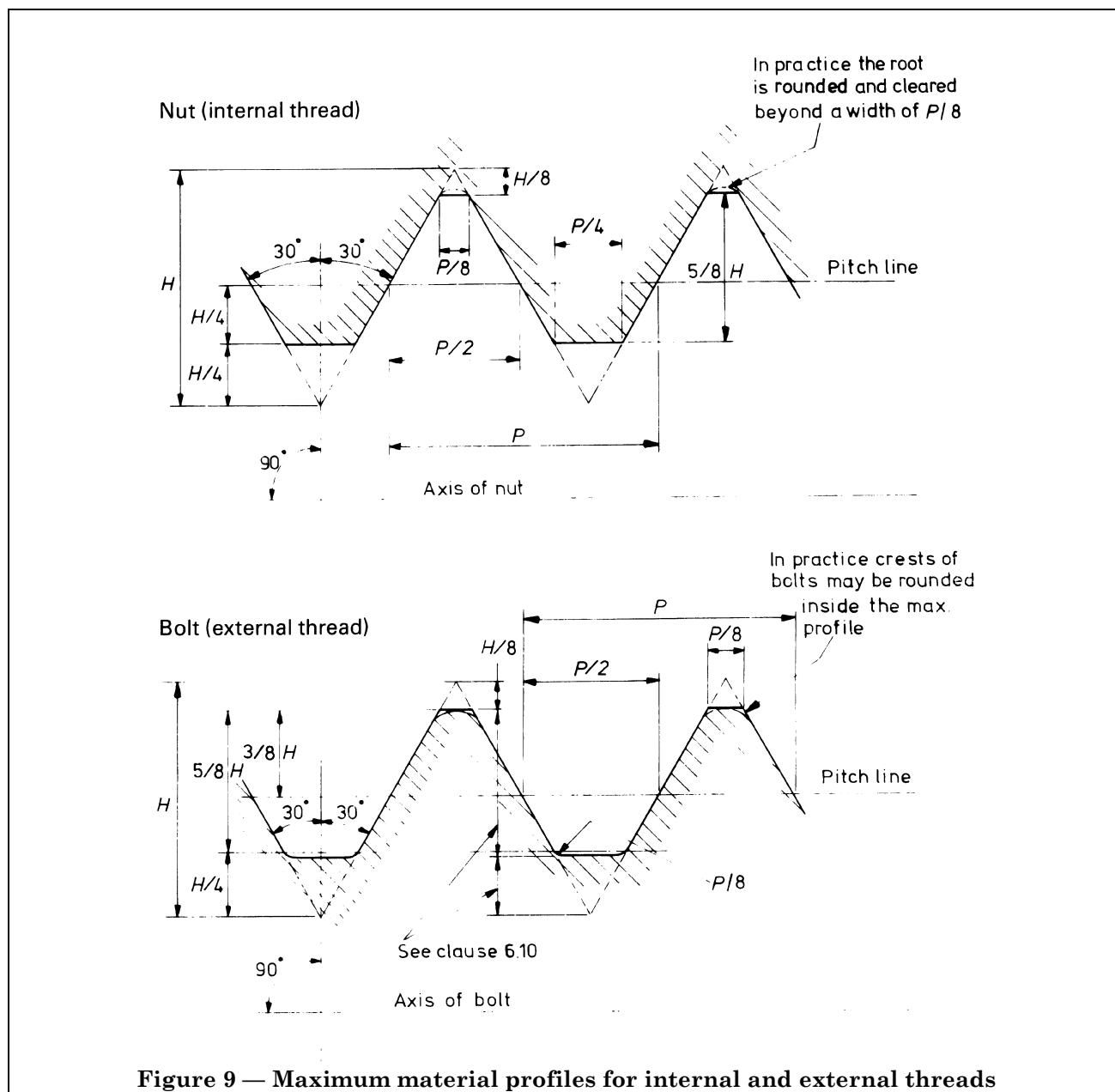

<sup>2)</sup> Based on ISO/DIS 4042 "Electroplated coatings on threaded components".

## A.3 External threads: stress areas

$$\text{Stress area } A_s = \frac{\pi}{4} \left( \frac{d_2 + d_3}{2} \right)^2$$

where

$d_2$  is the basic pitch diameter

$d_3$  is the minor diameter =  $d_1 - \frac{H}{6}$

$d_1$  being the basic minor diameter

$H$  being the height of the fundamental triangle for the thread.

Coarse series

Nominal thread diameter mm	Pitch of the thread mm	Nominal stress area mm <sup>2</sup>
1	0,25	0,46
1,1	0,25	0,59
1,2	0,25	0,73
1,4	0,3	0,98
1,6	0,35	1,27
1,8	0,35	1,7
2	0,4	2,07
2,2	0,45	2,48
2,5	0,45	3,39
3	0,5	5,03
3,5	0,6	6,78
4	0,7	8,78
5	0,8	14,2
6	1	20,1
7	1	28,9
8	1,25	36,6
10	1,5	58,0
12	1,75	84,3
14	2	115
16	2	157
18	2,5	192
20	2,5	245
22	2,5	303
24	3	353
27	3	459
30	3,5	561
33	3,5	694
36	4	817
39	4	976
42	4,5	1 121
45	4,5	1 306
48	5	1 473
52	5	1 758
56	5,5	2 030
60	5,5	2 362
64	6	2 676
68	6	3 055

Fine series

Nominal thread diameter mm	Pitch of the thread mm	Nominal stress area mm <sup>2</sup>
1	0,2	0,52
1,1	0,2	0,65
1,2	0,2	0,81
1,4	0,2	1,16
1,6	0,2	1,57
1,8	0,2	2,04
2	0,25	2,45
2,2	0,25	3,03
2,5	0,35	3,71
3	0,35	5,61
3,5	0,35	7,90
4	0,5	9,79
4,5	0,5	12,8
5	0,5	16,1
6	0,75	22
7	0,75	31,3
8	1	39,2
10	1,25	61,2
12	1,25	92,1
14	1,5	125
16	1,5	167
18	1,5	216
20	1,5	272
22	1,5	333
24	2	384
27	2	496
30	2	621
33	2	761

**A.4 External threads: minor diameters.** Minor diameter for external threads can be calculated using the information given in 6.10.

The minimum minor diameters will normally be tabulated in Part 2. In the case of the maximum minor diameters, these shall be less than the minimum minor diameter of the Go gauges according to BS 919-3.

## Appendix B Outline guide and examples for calculating limits of size of untabulated metric screw threads

The examples given below are intended to illustrate the method of calculation to use for untabulated threads. In cases where the data is not included in the referenced table\*, the formula shown should be used.

*Example 1: External (bolt) thread M30 × 1,255g6g*

Feature	Symbol	Table	Formula	Value
Basic major diameter	$d$	—	Nominal size	30,000
Basic pitch diameter	$d_2$	4*	$d - 0.6495 \text{ pitch}$	29,188
Basic minor diameter	$d_1$	4*	$d - 1.0825 \text{ pitch}$	28,647
(1) Fundamental deviation for tolerance position g	} $es$	5	<b>6.12.2</b>	0,028
Maximum major diameter				
(2) Major diameter tolerance for tolerance grade 6	} $T_d$	8	<b>6.12.4</b>	0,212
Minimum major diameter				
Maximum pitch diameter	$d_{2_{\max}}$		$d_2 - es$	29,160
(3) Pitch diameter tolerance for tolerance grade 5	} $T_{d_2}$	10*	<b>6.12.5</b>	0,108
Minimum pitch diameter				
Maximum minor diameter	$d_{1_{\max}}$		$d_1 - es - 2y^{(4)}$	28,568
Minimum root radius	$R_{\min}$	11	0.125 pitch	0.156
Minimum minor diameter	$d_{1_{\min}}$		$d_1 - es - 2z^{(4)}$	28,282

NOTE 1 Table 5 covers tolerance positions e, f, g and h.

NOTE 2 Table 8 covers tolerance grades 4, 6 and 8.

NOTE 3 Table 10 covers tolerance grades 3, 4, 5, 6, 7, 8 and 9.

NOTE 4 Explanation for dimensions y and z.

$$y = R_{\min} \left\{ 1 - \cos \left[ \frac{\pi}{3} - \arccos \left( 1 - \frac{Td_2}{4 \times R_{\min}} \right) \right] \right\}$$

$$z = \frac{H}{44} + \frac{Td_2}{22} - \frac{p}{88}$$

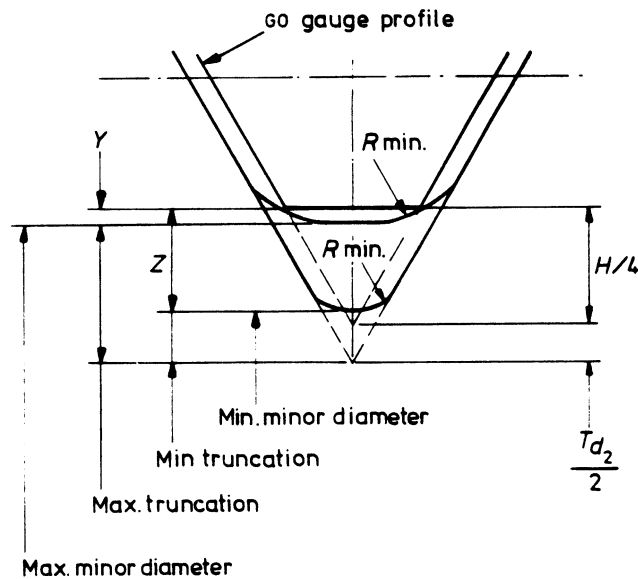

The maximum root profile shown in Figure 8 (see 6.10) and used for the calculation of the maximum minor diameter is theoretically possible but unlikely to occur in practice, since it would require the combination of maximum truncation at minor diameter and minimum material position on the thread flanks.

The maximum minor diameter will not normally be specified as part of the thread summary.

Summary:

External (bolt) thread  $M30 \times 1.25 - 5g6g$   
 Major diameter 29,972 – 29,760  
 Pitch diameter 29,160 – 29,052  
 Minor diameter 28,568 – 28,282

Example 2: Internal (nut) thread  $M345 \times 4-8G$

Feature	Symbol	Table	Formula	Value
Basic major diameter	$D$		Nominal size	345,000
Basic pitch diameter	$D_2$		$D - 0.6495 \text{ pitch}$	342,402
Basic minor diameter	$D_1$		$D - 1.0825 \text{ pitch}$	340,670
(5) Fundamental deviation for tolerance position G	$EI$	5		0,060
Minimum major diameter			$D_{\min}$	
Maximum major diameter	$D_{\max}$	—	Not required	—
Minimum pitch diameter	$D_{2\min}$		$D_2 + EI$	342,462
(6) Pitch diameter tolerance for tolerance grade 8	$T_{D_2}$	9*	<b>6.12.5<sup>(8)</sup></b>	0,600
Maximum pitch diameter			$D_{2\max}$	
Minimum minor diameter	$D_{1\min}$		$D_1 + EI$	0,730
(7) Minor diameter tolerance for tolerance grade 8	$T_{D_1}$	7		0,950
Maximum minor diameter			$D_{1\max}$	



NOTE 5 Table 5 covers tolerance positions G and H.

NOTE 6 Table 9 covers tolerance grades 4, 5, 6, 7 and 8.

NOTE 7 Table 7 covers tolerance grades 4, 5, 6, 7 and 8.

NOTE 8 It is important to note that where pitch diameter tolerances require calculation that it will be necessary firstly to calculate the equivalent  $T_{d_2}$  grade 6 for external (bolt) thread.

Summary:

Internal (nut) thread M345 × 4 – 8G

Major diameter 345,060 min.

Pitch diameter 342,462 – 343,062

Minor diameter 340,730 – 341,680



---

## Publications referred to

BS 919, *Screw gauge limits and tolerances.*

BS 919-3, *Gauges for ISO metric screw threads.*

BS 3643, *ISO metric screw threads.*

BS 3643-2, *Specification for selected limits of size.*

BS 6104-1, *Mechanical properties of fasteners — Part I: Bolts, screws and studs.*

BS 6293, *MJ threads for aerospace construction.*

BS 6293-1, *Specification for dimensions of basic profile.*

BS 6293-2, *Specification for dimensions for bolts and nuts.*

BS 6528, *Glossary of terms for cylindrical screw threads.*

PD 6494, *Mismatch of screw thread systems.*

ISO 68, *ISO general purpose screw threads — Basic profile.*

ISO 261, *ISO general purpose metric screw threads — General plan.*

ISO 262, *ISO general purpose metric screw threads — Selected sizes for screws, bolts and nuts.*

ISO 724, *ISO general purpose metric screw threads — Basic dimensions.*

ISO 965/1, *ISO general purpose metric screw threads — Tolerances — Part I: Principles and basic data.*

ISO 965/2, *ISO general purpose metric screw threads — Tolerances — Part 2: Limits of sizes for general purpose bolt and nut threads — Medium quality.*

ISO 965/3, *ISO general purpose metric screw threads — Tolerances — Part III: Deviations for constructional threads.*

---

# BSI — British Standards Institution

BSI is the independent national body responsible for preparing British Standards. It presents the UK view on standards in Europe and at the international level. It is incorporated by Royal Charter.

## Revisions

British Standards are updated by amendment or revision. Users of British Standards should make sure that they possess the latest amendments or editions.

It is the constant aim of BSI to improve the quality of our products and services. We would be grateful if anyone finding an inaccuracy or ambiguity while using this British Standard would inform the Secretary of the technical committee responsible, the identity of which can be found on the inside front cover. Tel: 020 8996 9000. Fax: 020 8996 7400.

BSI offers members an individual updating service called PLUS which ensures that subscribers automatically receive the latest editions of standards.

## Buying standards

Orders for all BSI, international and foreign standards publications should be addressed to Customer Services. Tel: 020 8996 9001. Fax: 020 8996 7001.

In response to orders for international standards, it is BSI policy to supply the BSI implementation of those that have been published as British Standards, unless otherwise requested.

## Information on standards

BSI provides a wide range of information on national, European and international standards through its Library and its Technical Help to Exporters Service. Various BSI electronic information services are also available which give details on all its products and services. Contact the Information Centre. Tel: 020 8996 7111. Fax: 020 8996 7048.

Subscribing members of BSI are kept up to date with standards developments and receive substantial discounts on the purchase price of standards. For details of these and other benefits contact Membership Administration. Tel: 020 8996 7002. Fax: 020 8996 7001.

## Copyright

Copyright subsists in all BSI publications. BSI also holds the copyright, in the UK, of the publications of the international standardization bodies. Except as permitted under the Copyright, Designs and Patents Act 1988 no extract may be reproduced, stored in a retrieval system or transmitted in any form or by any means – electronic, photocopying, recording or otherwise – without prior written permission from BSI.

This does not preclude the free use, in the course of implementing the standard, of necessary details such as symbols, and size, type or grade designations. If these details are to be used for any other purpose than implementation then the prior written permission of BSI must be obtained.

If permission is granted, the terms may include royalty payments or a licensing agreement. Details and advice can be obtained from the Copyright Manager. Tel: 020 8996 7070.