

Reviewing The Basics Of Microstrip Lines

An understanding of the fundamentals of microstrip transmission lines can guide high-frequency designers in the proper application of this venerable circuit technology.

Leo G. Maloratsky

Principal Engineer

Rockwell Collins, 2100 West Hibiscus

Blvd., Melbourne, FL 32901; (407)

953-1729, e-mail: lmalora@

mbnotes.collins.rockwell.com.

PRINTED transmission lines are widely used, and for good reason. They are broadband in frequency. They provide circuits that are compact and light in weight. They are generally economical to produce since they are readily adaptable to hybrid and monolithic integrated-circuit (IC) fabrication technologies at RF and microwave frequencies. To better appreciate printed transmission lines, and microstrip in particular, some of the basic principles of microstrip lines will be reviewed here.

A number of different transmission lines are generally used for microwave ICs (MICs) as shown in Fig. 1. Each type has its advantages

with respect to the others. In Fig. 1, it should be noted that the substrate materials are denoted by the dotted areas and the conductors are indicated by the bold lines.

The microstrip line is a transmission-line geometry with a single conductor trace on one side of a dielectric substrate and a single ground plane on the opposite side. Since it is an open structure, microstrip line has a major fabrication advantage over stripline. It also features ease of interconnections and adjustments.

In a microstrip line, the wavelength, Λ , is given by:

$$\Lambda = \lambda / (\epsilon_{\text{eff}})^{0.5} \quad (1)$$

where:

ϵ_{eff} = the effective dielectric constant, which depends on the dielectric constant of the substrate material and the physical dimensions of the microstrip line, and

λ = the free-space wavelength.

In a microstrip line, the electromagnetic (EM) fields exist partly in the air above the dielectric substrate and partly within the substrate itself. Intuitively, the effective dielectric constant of the line is expected to be greater than the dielectric constant

	Basic lines	Modifications		
Microstrip line				
Stripline				
Suspended stripline				
Slotline				
Coplanar waveguide				
Finline				

1. These are commonly used types of printed transmission lines for MICs.

Microstrip Lines

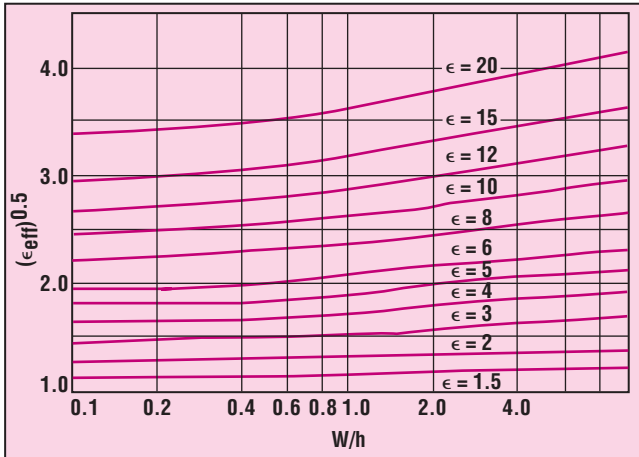

2. The values of effective dielectric constant are shown for different substrate relative dielectric constants as a function of W/h.

of air (1) and less than that of the dielectric substrate.¹ Various curves for effective dielectric constant are shown in Fig. 2 as a function of physical dimensions and relative dielectric constant.

Referring again to Fig. 1, it should be apparent that a basic (unshielded) microstrip line is not really a practical structure. It is

open to the air and, in reality, it is desirable to have circuits that are covered to protect them from the environment as well as to prevent radiation and EM interference (EMI). Also, the microstrip configurations that have been so far discussed are transversally infinite in extent, which deviates from reality. Covering the basic microstrip configuration with metal top plates on the top and on the sides leads to a more realistic circuit configuration, a shielded microstrip line with a housing (Fig. 1).

The main purposes of the housing or package are to provide mechanical strength, EM shielding, hermetization, and heat sinking in the case of high-power applications. Packaging must protect the circuitry from moisture, humidity, dust, salt spray, and other environmental contaminants. In order to protect the circuit, certain methods of sealing can be used: conductive epoxy, solder, gasket materials, and metallization tape.

An MIC mounted into a housing may be looked on as a dielectrically loaded cavity resonator (Fig. 3, left) with the following inner dimensions: a is the width, l is the length, and H is the height of the enclosure. These dimensions should be selected in a way so that the waveguide modes are below cutoff.

The parasitic modes appear in this resonator if:

$$H = \{h[l - (l/\epsilon)]R\}l(R - 1) \quad (2)$$

where:

$$R = (\lambda_0 / 2)^2 [(M / l)^2 + (N / a)^2] (2a)$$

A comparison of various transmission-line types

Transmission line	Q factor	Radiation	Dispersion	Impedance range	Chip mounting
Microstrip (dielectric) (GaAs, Si)	250 100 to 150	Low High	Low	20 to 120	Difficult for shunt, easy for series
Stripline	400	Low	None	35 to 250	Poor
Suspended stripline	500	Low	None	40 to 150	Fair
Slotline	100	Medium	High	60 to 200	Easy for shunt, difficult for series
Coplanar waveguide	150	Medium	Low	20 to 250	Easy for series and shunt
Finline	500	None	Low	10 to 400	Fair

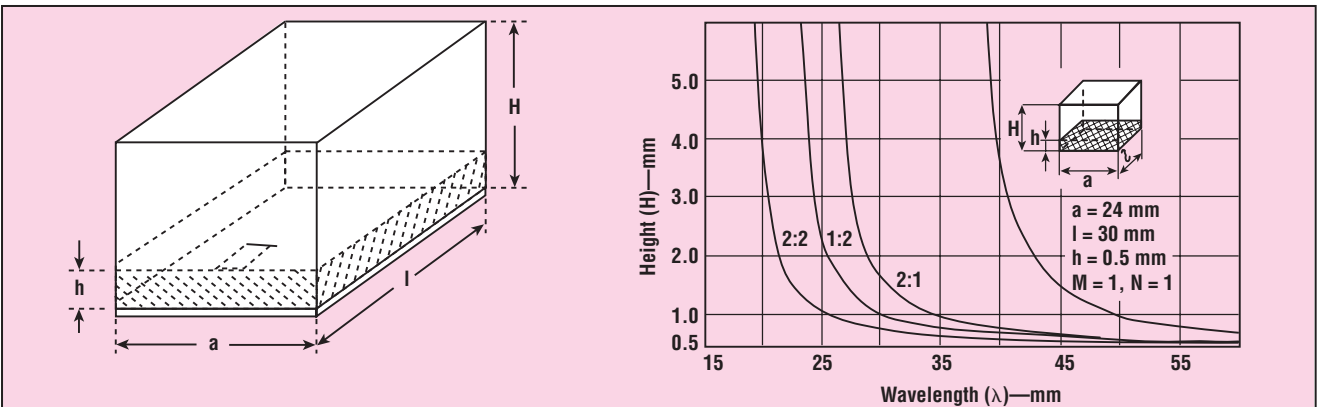

3. Housing dimensions are selected for microstrip circuits (left) to minimize losses. The effects of unfavorable housing height versus wavelength and different parasitic modes is shown (right).

Microstrip Lines

and M and $N =$ positive integers.
 From eq. 2, it is possible to obtain the condition of absence of parasitic modes:

$$R - 1 < 0; R < 1$$

or

$$\lambda_0^2 < 4 / [(M/l)^2 + (N/a)^2] \quad (3)$$

or

$$\lambda_0 < 2 / [(M/l)^2 + (N/a)^2]^{0.5} \quad (4)$$

Equation 4 is known as the condition for wave propagation in a waveguide with dimensions $l \times a$. In the case of this article, it can also be considered the condition for the absence of parasitic modes in a waveguide of cross-section $a \times H$ or $l \times H$. If eq. 4 is not satisfied, parasitic modes can arise, and the height H must be chosen to suppress these modes. Figure 3 (right) illustrates the resulting graphs of unfavorable H versus λ_0 for housing dimensions of $a = 24$ mm, $l = 30$ mm, and dielectric substrate with a dielectric constant of 9.8 and THK of 0.5 mm.

The top and side covers essentially redistribute the field of the more theoretical microstrip and understandably have an influence on the effective dielectric constant.

Figure 4 shows the relationship between the effective dielectric constant and the physical dimensions of the shielded microstrip line for different values of the relative dielectric constant of the substrate material.² In these curves, it has been

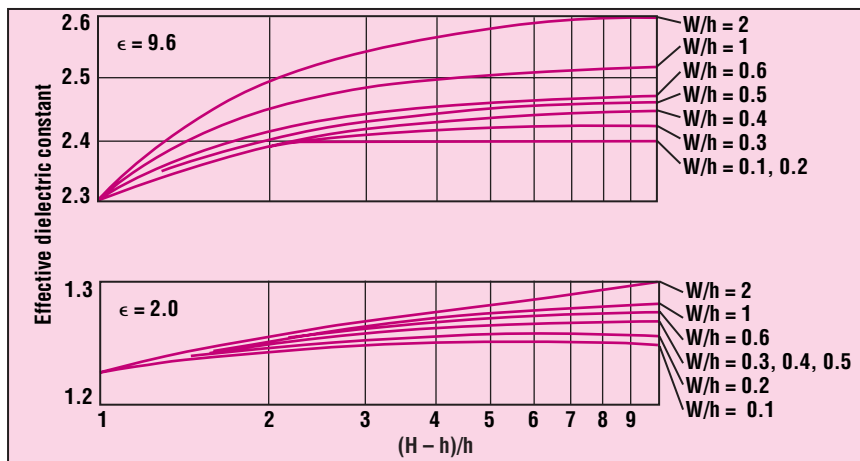

4. The effective dielectric constant is shown as a function of the relative dielectric constant and physical dimensions for a shielded microstrip line.

assumed that the side walls are sufficiently spaced so that they only see weak fringing fields and, therefore, have a negligible effect on the effective dielectric constant. The top cover tends to lower the effective dielectric constant (which is consistent with intuition). The top wall enables electric fields in the air above the strip conductor thereby giving the air more influence in determining the propagation characteristics.

The characteristic impedance of a microstrip line may be approximately calculated by assuming that the EM field in the line has a quasi transverse-EM (TEM) nature. The characteristic impedance of a microstrip line can be calculated using the Wheeler equations.^{3,4}

Figure 5 shows the characteristic impedance of microstrip lines for var-

ious geometries and substrates of different relative dielectric constants while Fig. 6 illustrates the relationships between characteristic impedance and the physical dimensions of shielded microstrip lines for two examples: substrates with low (2) and high (9.6) relative dielectric constants.² The top cover tends to reduce the impedance. When the ratio of the distance from the top cover to the dielectric substrate and the substrate thickness $[(H - h)/h]$ is greater than 10, the enclosure effects can be considered negligible. The characteristic impedance range of a microstrip line is 20 to 120 Ω . The upper limit is set by production tolerances while the lower limit is set by the appearance of higher-order modes.

There are three types of losses that occur in microstrip lines: con-

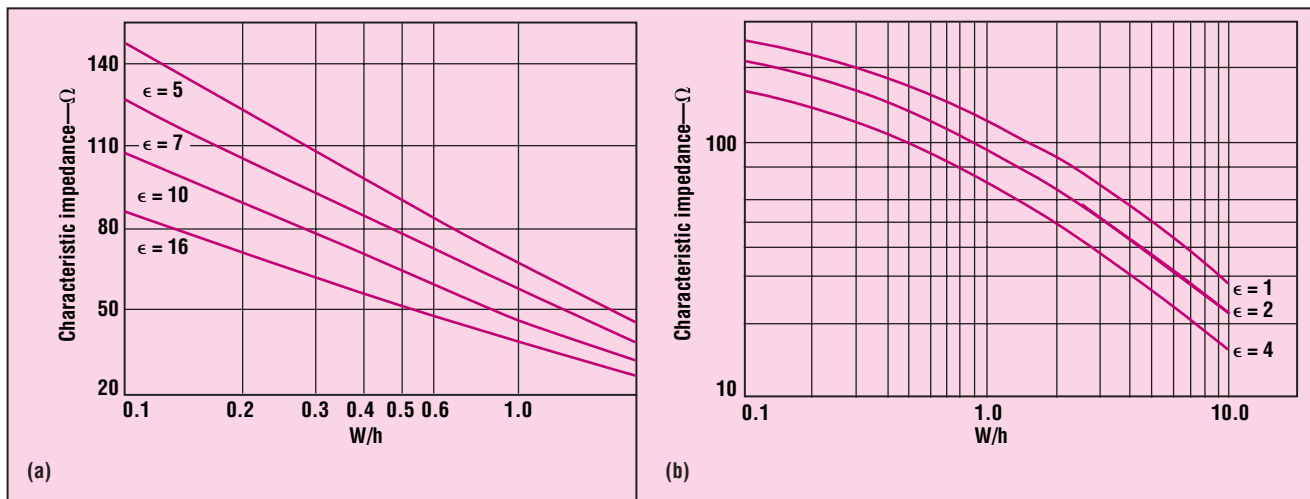

5. The characteristic line impedance has been plotted for substrates with high (a) and low (b) dielectric constants.

Microstrip Lines

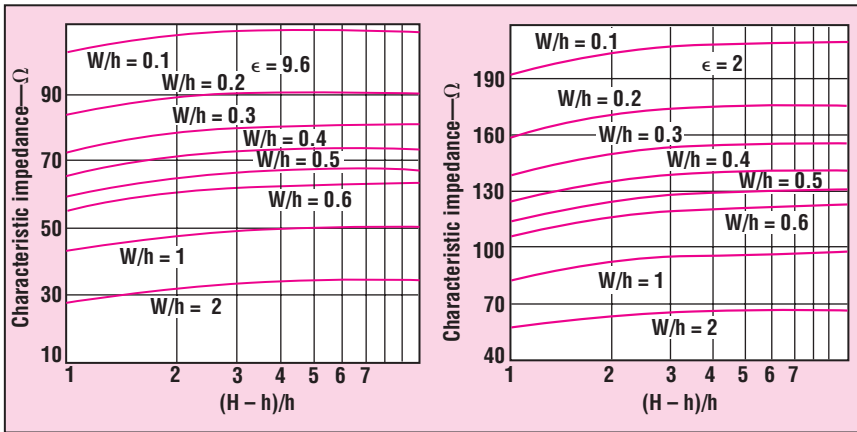

6. These plots show the relationship between the characteristic impedance and the physical dimensions of microstrip lines using substrates with high (9.6, left) and low (2.0, right) dielectric constants.

ductor (or ohmic) losses, dielectric losses, and radiation losses. An idealized microstrip line, being open to a semi-infinite air space, acts similar to an antenna and tends to radiate energy. Substrate materials with low dielectric constants (5 or less) are used when cost reduction is the priority. Similar materials are also used at millimeter-wave frequencies to avoid excessively tight mechanical tolerances. However, the lower the

dielectric constant, the less the concentration of energy is in the substrate region and, hence, the more are the radiation losses. Radiation losses depend on the dielectric constant, the substrate thickness, and the circuit geometry.

The use of high-dielectric-constant substrate materials reduces radiation losses because most of the EM field is concentrated in the dielectric between the conductive strip and the

ground plane. The real benefit in having a higher dielectric constant is that the package size decreases by approximately the square root of the dielectric constant. This is an advantage at lower frequencies but may be a problem at higher frequencies.

In most conventional microstrip designs with high substrate dielectric constant, conductor losses in the strip conductor and the ground plane dominate over dielectric and radiation losses. Conductor losses are a result of several factors related to the metallic material composing the ground plane and walls, among which are conductivity, skin effects, and surface roughness. With finite conductivity, there is a non-uniform current density starting at the surface and exponentially decaying into the bulk of the conductive metal. This is the alleged skin effect and its effects can be visualized by an approximation consisting of a uniform current density flowing in a layer near the surface of the metallic elements to a uniform skin depth, δ . The skin depth of a conductor is defined as the distance to the conductor (Fig. 7) where the current density drops to $1/e$ from a maximum current density of I_{max} , or 37 percent of its value at the surface of the conductor.

To minimize conductor loss while simultaneously minimizing the amount of metallic material flanking the dielectric, the conductor thickness should be greater than approximately three to five times the skin depth.

In a microstrip line, conductor losses increase with increasing characteristic impedance due to the greater resistance of narrow strips. Conductor losses follow a trend which is opposite to radiation loss with respect to W/h .

The fabrication process of real microstrip devices creates scratches and bumps on the metal surfaces. A cross-section of a microstrip line is shown in Fig. 7. The inside surfaces of the strip conductor and the ground plane facing the substrate repeat the shape of the substrate. The current, concentrated in the metal surface next to the substrate, follows the uneven surface of the substrate and encounters a greater resistance com-

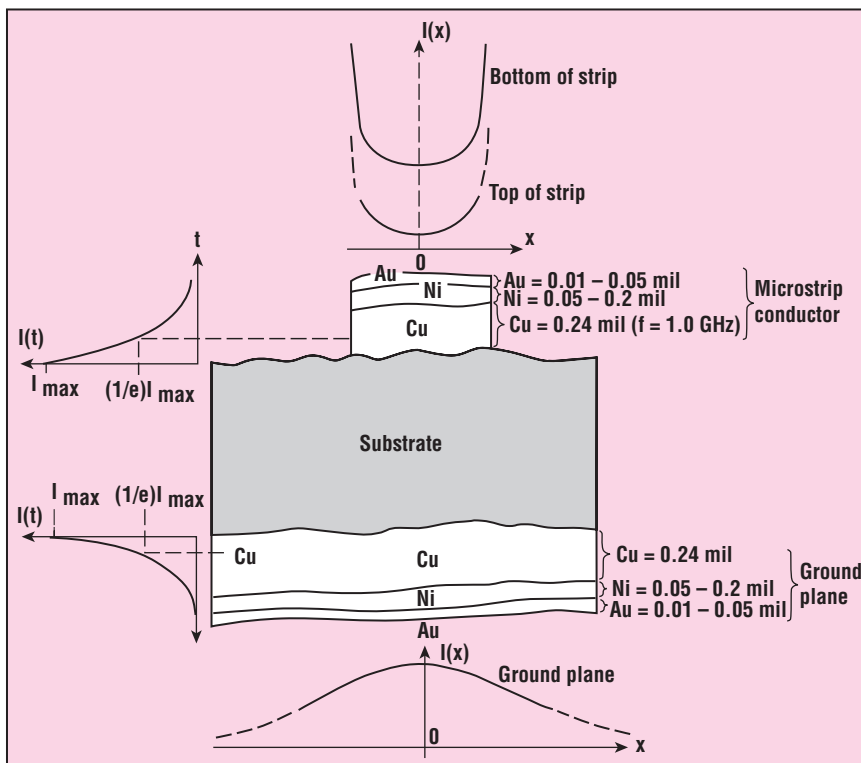

7. This cross-sectional view shows the current distribution across a microstrip conductor and its ground plane.

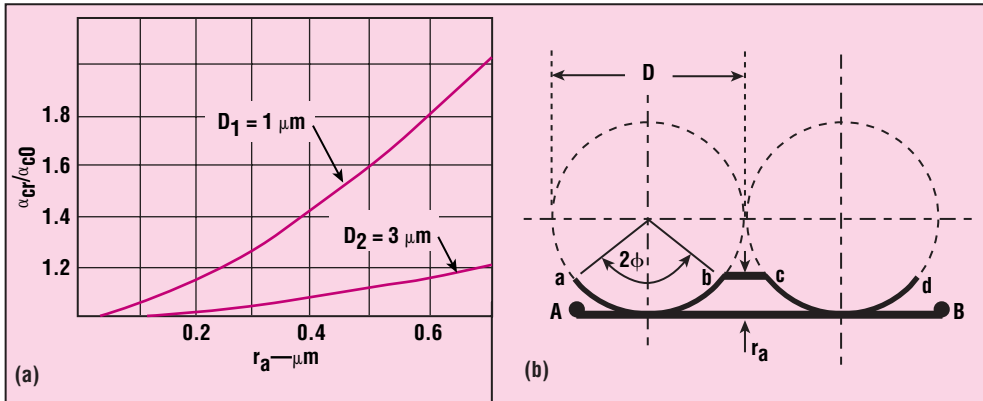

8. The profile of a substrate's uneven surface (a) shows how surface roughness affects normalized conductor losses (b).

pared to the case of a smooth substrate. As the roughness of the surface increases, the length of the current path increases and, therefore, the losses increase.

Consider a substrate surface which, for example, coincides with the shape of the diamond abrasive material that is used to polish the substrate. The path of the current in conductor segment a-d (Fig. 8a) is shown by the line abcd. For an ideally smooth surface, the length of the current path AB is: $L_{AB} = Dn$ where:

n = the number of diamond abrasives within segment AB.

The ratio of conductor losses in the case of an uneven surface, α_{cr} , to losses in the case of a perfectly smooth surface, α_{co} ,² is:

$$\alpha_{cr} / \alpha_{co} = 1 + \arccos [1 - (4r_a / D)] - 2\{[(2r_a / D)[1 - (2r_a / D)]\}^{0.5} \quad (5)$$

Using eq. 5, α_{cr}/α_{co} can be plotted as a function of r_a for $D_1 = 1 \mu\text{m}$ and $D_2 = 3 \mu\text{m}$ (Fig. 8b). Analysis of the resulting functions shows that for smaller diameters, conductor losses in the microstrip line are more dependent on the unevenness of the substrate roughness because the extra path length a surface (or skin) current sees is less. For example, consider a copper (Cu) microstrip line with sapphire substrate where typically the roughness is $1 \mu\text{m}$.⁵ The skin depth at a few gigahertz is $1 \mu\text{m}$ and the loss is increased approximately 60 percent when the surface roughness is taken into account.

To minimize dielectric losses, high-quality, low-loss dielectric substrates, such as alumina, quartz, and sapphire, are typically used in hybrid ICs. For most microstrip lines, conductor losses greatly exceed dielectric losses. However, in monolithic microwave ICs (MMICs), silicon (Si) or GaAs substrates result in much larger dielectric losses (approximately 0.04 dB/mm).⁵

The preceding sections have considered the individual contributions to losses in microstrip by radiation, ohmic, and dielectric effects. These individual loss components are at most first-order perturbations in the

overall EM wave propagation and, consequently, can be combined linearly. To do so, it is convenient to consider the total Q factor, which can be expressed by:

$$1/Q = (1/Q_c) + (1/Q_d) + (1/Q_r)$$

where:

Q_c , Q_d , and Q_r are the quality factors corresponding to the conductor, dielectric, and radiation losses, respectively. The unloaded Q factor of the microstrip line is typically on the order of 250.

CHOOSING DIMENSIONS

For all circuit considerations, a basic approach involves starting with the particular ranges of dimension ratios required to achieve a desired characteristic impedance. Following that, the strip width should be minimized to decrease the overall dimensions, as well as to suppress higher-order modes. It is important to remember, however, that a smaller strip width leads to higher losses.

Factors that affect the choice of substrate thickness are the most contro-

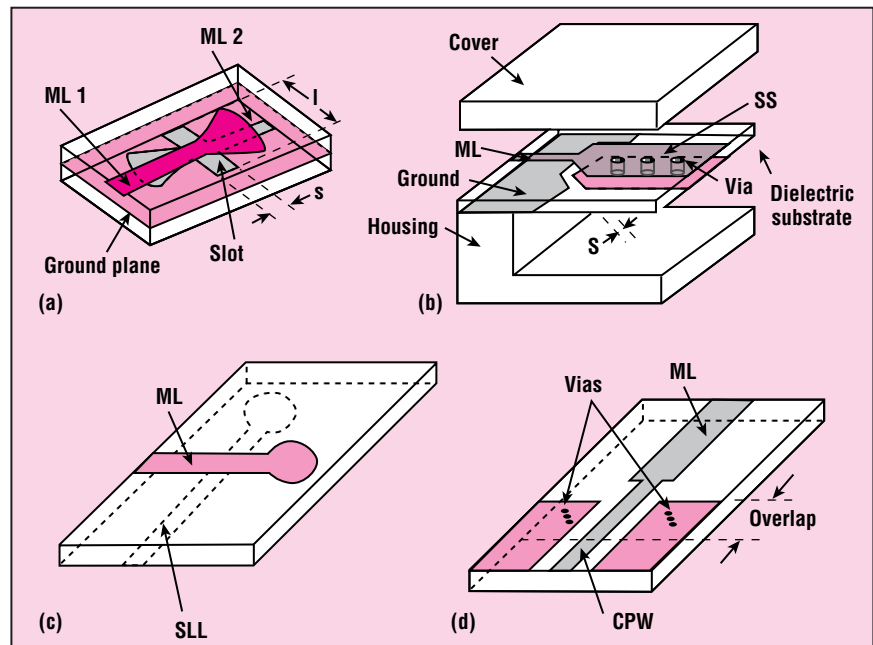

9. Various transitions between microstrip and other circuit structures are possible: microstrip to microstrip (a), microstrip to suspended stripline (b), microstrip to slotted line (c), and microstrip to coplanar waveguide (d).

versial. The positive effects of decreasing substrate thickness are compact circuits, ease of integration, less tendency to launch higher-order modes or radiation, and via holes drilled through the dielectric substrate will contribute smaller parasitic inductances to the overall performance.

However, a decrease in the substrate thickness (h) while maintain-

ing a constant characteristic impedance, Z_0 , must be accompanied by a narrowing of the conductor width, W . Narrowing W leads to higher conductor losses along with a lower Q . Also, for smaller W and h , the fabrication tolerances become more severe. Careless handling of thin substrates can cause stress and strain which can modify the performance of

the substrate.

Microstrip circuit dimensions decrease with increasing substrate dielectric constant. Losses then usually increase because higher dielectric constant materials usually have higher loss tangents, $\tan \delta$, and also because for the same characteristic impedance, reduced conductor line widths have higher ohmic losses. This is a typical conflicting situation between the necessary requirements for small dimensions and low loss. For many applications, lower dielectric constants are preferred since losses are reduced, conductor geometries are larger (and, therefore, more producible), and the cutoff frequency of the circuit increases.

MICROSTRIP TRANSITIONS

The rapid development of high-density modules requires the design of interconnects and transitions, especially for multilayer circuits. Consider useful transitions from microstrip to other printed transition lines. A transition between two microstrip lines (Fig. 9a) can be realized through a slot in the ground plane.

A transition between a microstrip line and a suspended stripline circuit is shown in Fig. 9b.

A transition between a slotline and a microstrip line can be seen in Fig. 9c.^{7,8}

An overlay transition between a microstrip line and coplanar waveguide (CPW) is shown (Fig. 9d).^{9,10} ●●

Acknowledgment

The author would like to thank Dr. Paul Chorney who reviewed these materials and provided valuable suggestions.

References

1. H. Sobol, "Application of Integrated Circuit Technology to Microwave Frequencies," *Proceedings of the IEEE*, Vol. 59, 1971, pp. 1200-1211.
2. L.G. Maloratsky, *Miniaturization of Microwave Elements and Devices*, Soviet Radio, Moscow, 1976.
3. H.A. Wheeler, "Transmission-Line Properties of a Strip on a Dielectric Sheet on a Plane," *IEEE Transactions on Microwave Theory & Techniques*, Vol. 25, No. 8, August 1977, pp. 631-647.
4. H.A. Wheeler, "Transmission-Line Properties of Parallel Strips Separated by a Dielectric Sheet," *IEEE Transactions on Microwave Theory & Techniques*, Vol. 3, No. 3, March 1965, pp. 172-185.
5. T.C. Edwards, *Foundations for Microstrip Circuit Design*, Wiley, New York, 1981.
6. K.J. Herrick, J.G. Yook, and P.B. Katehi, "Microtechnology in the Development of Three-Dimensional Circuits," *IEEE Transactions on Microwave Theory & Techniques*, Vol. 46, No. 11, November 1998.
7. S.B. Cohn, "Slot-Line on a Dielectric Substrate," *IEEE Transactions on Microwave Theory & Techniques*, Vol. 17, 1969, pp. 768-778.
8. J.S. Izadian and S.M. Izadian, *Microwave Transition Design*, Artech House, Norwood, MA, 1988.
9. M. Hougart and C. Aury, "Various Excitation of Coplanar Waveguides," *IEEE MTT-S International Microwave Symposium Digest*, 1979.
10. J. Burke and R.W. Jackson, "Surface-to-Surface Transition via Electromagnetic Coupling of Microstrip and Coplanar Waveguide," *IEEE Transactions on Microwave Theory & Techniques*, Vol. 37, No. 3, March 1989, pp. 519-525.