

## ***AN-71 Micropower Circuits Using the LM4250 Programmable Op Amp***

---

### **ABSTRACT**

The LM4250 is a highly versatile monolithic operational amplifier. A single external programming resistor determines the quiescent power dissipation, input offset and bias currents, slew rate, gain-bandwidth product, and input noise characteristics of the amplifier. Since the device is in effect a different op amp for each externally programmed set current, it is possible to use a single stock item for a variety of circuit functions in a system.

### **Contents**

1	Introduction .....	3
2	Circuit Description LM4250 .....	3
3	Bias Current Setting Procedure .....	4
4	Frequency Response of a Programmable Op Amp .....	6
5	Small Signal Sine Wave Response .....	6
6	Small Signal Step Input Response .....	6
7	Slew Rate Limited Large Signal Response .....	7
8	Full Power Bandwidth .....	8
9	500 Mano-Watt X10 Amplifier .....	8
10	Micro-Power Monitor with High Current Switch .....	9
11	IC Meter Amplifier Runs on Two Flashlight Batteries .....	10
12	The Complete Nanoammeter .....	10
13	Circuit for Higher Current Readings .....	11
14	A 10 mV to 100V Full-Scale Voltmeter .....	12
15	Low Frequency Pulse Generator Using a Single +5V Supply .....	12
16	X100 Instrumentation Amplifier .....	14
17	5V Regulator for Cmos Logic Circuits .....	15
18	References .....	15

### **List of Figures**

1	LM4250 Schematic Diagram .....	3
2	Input Resistance vs $I_{SET}$ .....	4
3	3a .....	5
4	3c.....	5
5	3b .....	5
6	Biasing Schemes.....	6
7	Bode Plot.....	6
8	Frequency vs Slew Rate Limit vs Peak Output Voltage .....	7
9	Slew Rate vs Rise Time vs Step Voltage.....	8
10	500 nW x 10 Amplifier .....	9
11	$\mu$ -Power Comparator with High Current Switch .....	9
12	Basic Meter Amplifier .....	10
13	Complete Meter Amplifier .....	10

All trademarks are the property of their respective owners.

---

14	Ammeter .....	11
15	Voltmeter .....	12
16	Pulse Generator .....	12
17	Pulse Frequency vs $R_2$ .....	13
18	$\times 100$ Instrumentation Amplifier .....	14
19	$A_v$ and CMRR vs Frequency .....	15
20	350 $\mu$ W Quiescent Drain 5 Volt Regulator .....	16

**List of Tables**

1	Resistance Values for DC Nano and Micro Ammeter .....	11
2	Resistance Values for DC Ammeter .....	11
3	Resistance Values for a DC Voltmeter .....	12

## 1 Introduction

The LM4250 is a highly versatile monolithic operational amplifier. A single external programming resistor determines the quiescent power dissipation, input offset and bias currents, slew rate, gain-bandwidth product, and input noise characteristics of the amplifier. Since the device is in effect a different op amp for each externally programmed set current, it is possible to use a single stock item for a variety of circuit functions in a system.

This paper describes the circuit operation of the LM4250, various methods of biasing the device, frequency response considerations, and some circuit applications exercising the unique characteristics of the LM4250.

## 2 Circuit Description LM4250

The LM4250 has two special features when compared with other monolithic operational amplifiers. One is the ability to externally set the bias current levels of the amplifiers, and the other is the use of PNP transistors as the differential input pair.

Referring to Figure 1, Q<sub>1</sub> and Q<sub>2</sub> are high current gain lateral PNPs connected as a differential pair. R<sub>1</sub> and R<sub>2</sub> provide emitter degeneration for greater stability at high bias currents. Q<sub>3</sub> and Q<sub>4</sub> are used as active loads for Q<sub>1</sub> and Q<sub>2</sub> to provide high gain and also form a current inverter to provide the maximum drive for the single ended output into Q<sub>5</sub>. Q<sub>5</sub> is an emitter follower which prevents loading of the input stage by the succeeding amplifier stage.

One advantage of this lateral PNP input stage is a common mode swing to within 200 mV of the negative supply. This feature is especially useful in single supply operation with signals referred to ground. Another advantage is the almost constant input bias current over a wide temperature range. The input resistance R<sub>IN</sub> is approximately equal to  $2\beta(R_E + r_e)$  where  $\beta$  is the current gain,  $r_e$  is the emitter resistance of one of the input lateral PNPs, and R<sub>E</sub> is the resistance of one of the 10 k $\Omega$  emitter resistor. Using a DC beta of 100 and the normal temperature dependent expression for  $r_e$  gives:

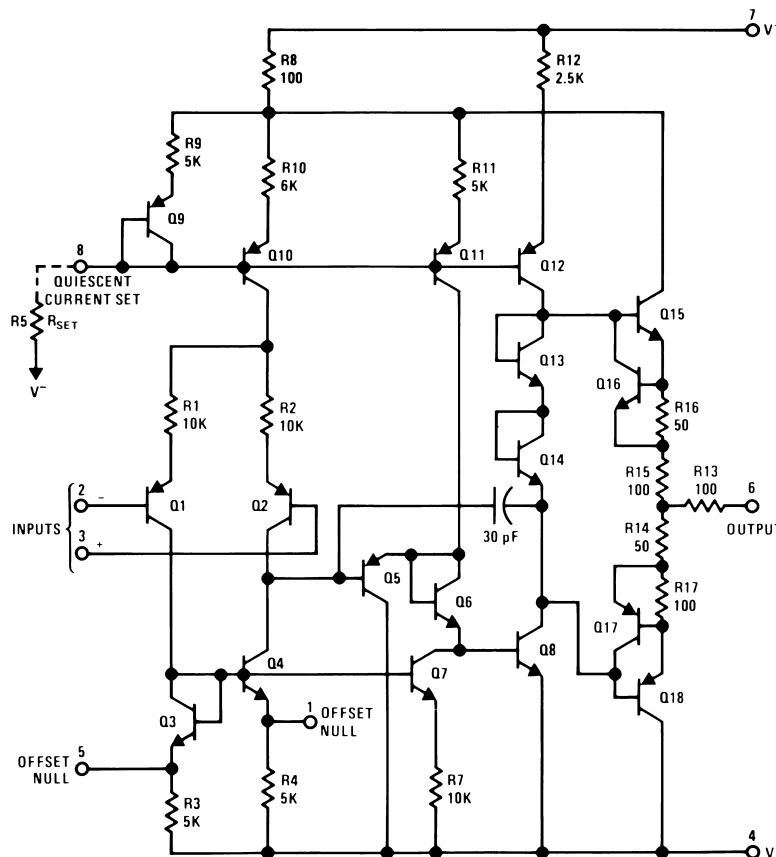
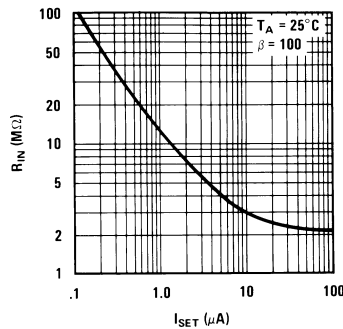

Figure 1. LM4250 Schematic Diagram

$$R_{IN} \approx 2 \text{ M}\Omega + 2 \frac{kT}{qI_B} \quad (1)$$

where  $I_B$  is input bias current. At room temperature this formula becomes:

$$R_{IN} \approx 2 \text{ M}\Omega + \frac{52 \text{ mV}}{I_B} \quad (2)$$



**Figure 2. Input Resistance vs  $I_{SET}$**

Figure 2 gives a typical plot of  $R_{IN}$  vs  $I_{set}$  derived from the above equation.

Continuing with the circuit description,  $Q_6$  level shifts downward to the base of  $Q_8$  which is the second stage amplifier.  $Q_8$  is run as a common emitter amplifier with a current source load ( $Q_{12}$ ) to provide maximum gain. The output of  $Q_8$  drives the class B complementary output stage composed of  $Q_{15}$  and  $Q_{18}$ .

The bias current levels in the LM4250 are set by the amount of current ( $I_{set}$ ) drawn out of Pin 8. The constant current sources  $Q_{10}$ ,  $Q_{11}$ , and  $Q_{12}$  are controlled by the amount of  $I_{set}$  current through the diode connected transistor  $Q_9$  and resistor  $R_9$ . The constant collector current from  $Q_{10}$  biases the differential input stage. Therefore, the level  $Q_{10}$  is set at will control such amplifier characteristics as input bias current, input resistance, and amplifier slew rate. Current source  $Q_{11}$  biases  $Q_5$  and  $Q_6$ . The current ratio between  $Q_5$  and  $Q_6$  is controlled by constant current sink  $Q_7$ . Current source  $Q_{12}$  sets the currents in diodes  $Q_{13}$  and  $Q_{14}$  which bias the output stage to the verge of conduction thereby eliminating the dead zone in the class B output.  $Q_{12}$  also acts as the load for  $Q_8$  and limits the drive current to  $Q_{15}$ .

The output current limiting is provided by  $Q_{16}$  and  $Q_{17}$  and their associated resistors  $R_{16}$  and  $R_{17}$ . When enough current is drawn from the output,  $Q_{16}$  turns on and limits the base drive of  $Q_{15}$ . Similarly  $Q_{17}$  turns on when the LM4250 attempts to sink too much current, limiting the base drive of  $Q_{18}$  and therefore output current. Frequency compensation is provided by the 30 pF capacitor across the second stage amplifier,  $Q_8$ , of the LM4250. This provides a 6 dB per octave rolloff of the open loop gain.

### 3 Bias Current Setting Procedure

The single set resistor shown in Figure 6a offers the most straightforward method of biasing the LM4250. When the set resistor is connected from Pin 8 to ground the resistance value for a given set current is:

$$R_{SET} = \frac{V^+ - 0.5}{I_{SET}} \quad (3)$$

The 0.5 volts shown in Equation 3 is the voltage drop of the master bias current diode connected transistor on the integrated circuit chip. In applications where the regulation of the  $V^+$  supply with respect to the  $V^-$  supply (as in the case of tracking regulators) is better than the  $V^+$  supply with respect to ground the set resistor should be connected from Pin 8 to  $V^-$ .  $R_{SET}$  is then:

$$R_{SET} = \frac{V^+ + |V^-| - 0.5}{I_{SET}} \quad (4)$$

The transistor and resistor scheme shown in Figure 6b allows one to switch the amplifier off without disturbing the main  $V^+$  and  $V^-$  power supply connections. Attaching  $C_1$  across the circuit prevents any switching transient from appearing at the amplifier output. The dual scheme shown in Figure 6c has a constant set current flowing through  $R_{S1}$  and a variable current through  $R_{S2}$ . Transistor  $Q_2$  acts as an emitter follower current sink whose value depends on the control voltage  $V_c$  on the base. This circuit provides a method of varying the amplifier's characteristics over a limited range while the amplifier is in operation. The FET circuit shown in Figure 6d covers the full range of set currents in response to as little as a 0.5V gate potential change on a low pinch-off voltage FET such as the 2N3687. The limit resistor prevents excessive current flow out of the LM4250 when the FET is fully turned on.



Figure 3. 3a

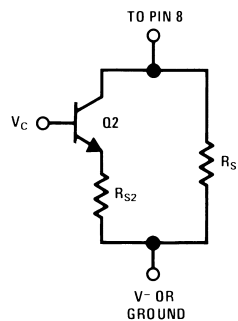

Figure 4. 3c

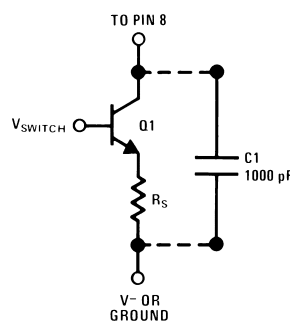
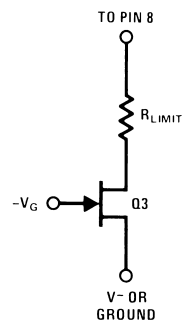

Figure 5. 3b



3d

**Figure 6. Biasing Schemes**

#### 4 Frequency Response of a Programmable Op Amp

This section provides a method of determining the sine and step voltage response of a programmable op amp. Both the sine and step voltage responses of an amplifier are modified when the rate of change of the output voltage reaches the slew rate limit of the amplifier. The following analysis develops the Bode plot as well as the small signal and slew rate limited responses of an amplifier to these two basic categories of waveforms.

#### 5 Small Signal Sine Wave Response

The key to constructing the Bode plot for a programmable op amp is to find the gain bandwidth product, GBWP, for a given set current. Quiescent power drain, input bias current, or slew rate considerations usually dictate the desired set current. The data sheet curve relating GBWP to set current provides the value of GBWP which when divided by one yields the unity gain crossover of  $f_u$ . Assuming a set current of  $6 \mu\text{A}$  gives a GBWP of 200,000 Hz and therefore an  $f_u$  of 200 kHz for the example shown in Figure 7. Since the device has a single dominant pole, the rolloff slope is  $-20 \text{ dB}$  of gain per decade of frequency ( $-6 \text{ dB/octave}$ ). The dotted line shown on Figure 7 has this slope and passes through the 200 kHz  $f_u$  point. Arbitrarily choosing an inverting amplifier with a closed loop gain magnitude of 50 determines the height of the 34 dB horizontal line shown in Figure 7. Graphically finding the intersection of the sloped line and the horizontal line or mathematically dividing GBWP by 50 determines the 3 dB down frequency of 4 kHz for the closed loop response of this amplifier configuration. Therefore, the amplifier will now apply a gain of  $-50$  to all small signal sine waves at frequencies up to 4 kHz. For frequencies above 4 kHz, the gain will be as shown on the sloped portion of the Bode plot.

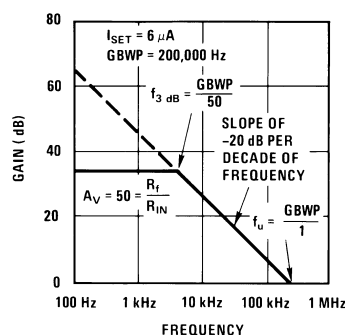
**Figure 7. Bode Plot**

#### 6 Small Signal Step Input Response

The amplifier's response to a positive step voltage change at the input will be an exponentially rising waveform whose rise time is a function of the closed loop 3 dB down bandwidth of the amplifier. The amplifier may be modeled as a single pole low pass filter followed by a gain of 50 wideband amplifier. From basic filter theory\*, the 10% to 90% rise time of a single pole low pass filter is:

$$t_r = \frac{0.35}{f_{3\text{ dB}}} \tag{5}$$

For the example shown in Figure 7 the 4 kHz 3 dB down frequency would give a rise time of 87.5 μs.

**NOTE:** \*See reference.

## 7 Slew Rate Limited Large Signal Response

The final consideration, which determines the upper speed limitation on the previous two types of signal responses, is the amplifier slew rate. The slew rate of an amplifier is the maximum rate of change of the output signal which the amplifier is capable of delivering. In the case of sinusoidal signals, the maximum rate of change occurs at the zero crossing and may be derived as follows:

$$V_o = V_p \sin 2\pi f t \tag{6}$$

$$\frac{dV_o}{dt} = 2\pi f V_p \cos 2\pi f t \tag{7}$$

$$\left. \frac{dV_o}{dt} \right|_{t=0} = 2\pi f V_p \tag{8}$$

$$S_r = 2\pi f_{\text{MAX}} V_p \tag{9}$$

where:

$$\begin{aligned} V_o &= \text{output voltage} \\ V_p &= \text{peak output voltage} \\ S_r &= \text{maximum } \frac{dV_o}{dt} \end{aligned} \tag{10}$$

The maximum sine wave frequency an amplifier with a given slew rate will sustain without causing the output to take on a triangular shape is therefore a function of the peak amplitude of the output and is expressed as:

$$f_{\text{MAX}} = \frac{S_r}{2\pi V_p} \tag{11}$$

Figure 8 shows a quick reference graphical presentation of this formula with the area below any  $V_{\text{peak}}$  line representing an undistorted small signal sine wave response for a given frequency and amplifier slew rate and the area above the  $V_{\text{peak}}$  line representing a distorted sine wave response due to slew rate limiting for a sine wave with the given  $V_{\text{peak}}$ .

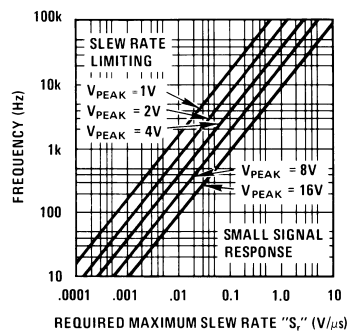
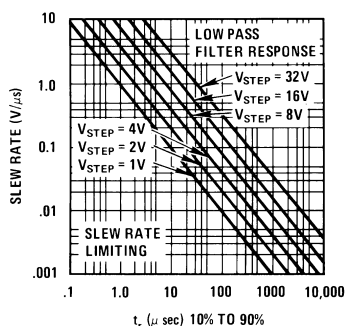

Figure 8. Frequency vs Slew Rate Limit vs Peak Output Voltage

Large signal step voltage changes at the output will have a rise time as shown in equation 5 until a signal with a rate of output voltage change equal to the slew rate of the amplifier occurs. At this point the output will become a ramp function with a slope equal to  $S_r$ . This action occurs when:

$$S_r \leq \frac{V_{\text{step}}}{t_r} \tag{12}$$



**Figure 9. Slew Rate vs Rise Time vs Step Voltage**

Figure 9 graphically expresses this formula and shows the maximum amplitude of undistorted step voltage for a given slew rate and rise time. The area above each step voltage line represents the undistorted low pass filter type response mode of the amplifier. If the intersection of the rise time and slew rate values of a particular amplifier configuration falls below the expected step voltage amplitude line, the rise time will be determined by the slew rate of the amplifier. The rise time will then be equal to the amplitude of the step divided by the slew rate  $S_r$ .

## 8 Full Power Bandwidth

The full power bandwidth often found on amplifier specification sheets is the range of frequencies from zero to the frequency found at the intersection on Figure 8 of the maximum rated output voltage and the slew rate  $S_r$  of the amplifier. Mathematically this is:

$$f_{\text{full power}} = \frac{S_r}{2\pi V_{\text{rated}}} \quad (13)$$

The full power bandwidth of a programmable amplifier such as the LM4250 varies with the master bias set current.

The above analysis of sine wave and step voltage amplifier responses applies for all single dominant pole op amps such as the LM101A, LM1107, LM108A, LM112, LM118, and LM741 as well as the LM4250 programmable op amp.

## 9 500 Mano-Watt X10 Amplifier

The X10 inverting amplifier shown in Figure 10 demonstrates the low power capability of the LM4250 at extremely low values of supply voltage and set current. The circuit draws 260 nA from the +1.0V supply of which 50 nA flows through the 12 MΩ set resistor. The current into the -1.0V supply is only 210 nA since the set resistor is tied to ground rather than  $V^-$ . Total quiescent power dissipation is:

$$P_D = (260 \text{ nA})(1\text{V}) + (210 \text{ nA})(1\text{V}) \quad (14)$$

$$P_D = 470 \text{ nW} \quad (15)$$

The slew rate determined from the data sheet typical performance curve is 1 V/ms for a .05 μA set current. Samples of actual values observed were 1.2 V/ms for the negative slew rate and 0.85 V/ms for the positive slew rate. This difference occurs due to the non-symmetry in the current sources used for charging and discharging the internal 30 pF compensation capacitor.

The 3 dB down (gain of -7.07) frequency observed for this configuration was approximately 300 Hz which agrees fairly closely with the 3.5 kHz GBWP divided by 10 taken from an extrapolation of the data sheet typical GBWP versus set current curve.

Peak-to-peak output voltage swing into a 100 kΩ load is 0.7V or ±0.35V peak. An increase in supply voltage to ±1.35V such as delivered by a pair of mercury cells directly increases the output swing by ±0.35V to 1.4V peak-to-peak. Although this increases the power dissipation to approximately 1 μW per battery, a power drain of 15 μW or less will not affect the shelf life of a mercury cell.



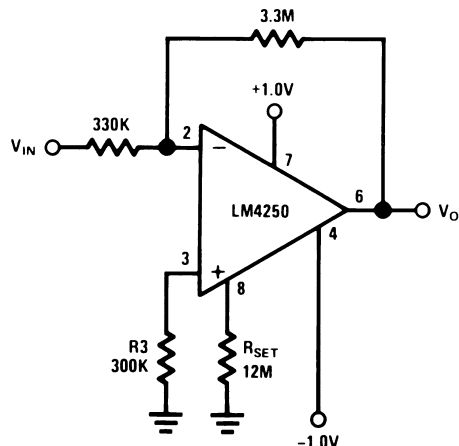

Figure 10. 500 nW x 10 Amplifier

## 10 Micro-Power Monitor with High Current Switch

Figure 11 shows the combination of a micro-power comparator and a high current switch run from a separate supply. This circuit provides a method of continuously monitoring an input voltage while dissipating only 100  $\mu$ W of power and still being capable of switching a 500 mA load if the input exceeds a given value. The reference voltage can be any value between +8.5V and -8.5V. With a minimum gain of approximately 100,000 the comparator can resolve input voltage differences down into the 0.2 mV region.

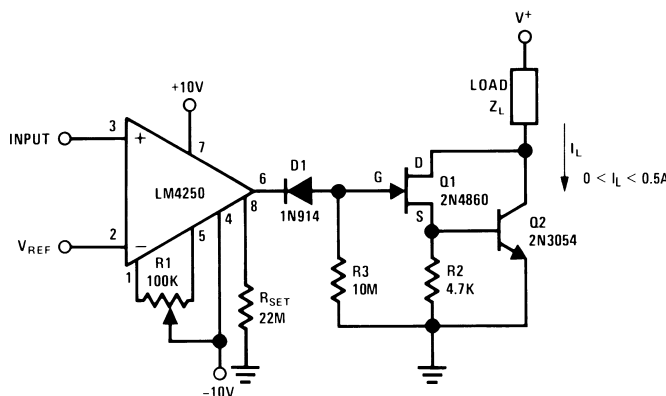

Figure 11.  $\mu$ -Power Comparator with High Current Switch

The bias current for the LM4250 shown in Figure 11 is set at 0.44  $\mu$ A by the 200 M $\Omega$   $R_{set}$  resistor. This results in a total comparator power drain of 100  $\mu$ W and a slew rate of approximately 11 V/ms in the positive direction and 12.8 V/ms in the negative direction. Potentiometer  $R_1$  provides input offset nulling capability for high accuracy applications. When the input voltage is less than the reference voltage, the output of the LM4250 is at approximately -9.5V causing diode  $D_1$  to conduct. The gate of  $Q_1$  is held at -8.8V by the voltage developed across  $R_3$ . With a large negative voltage on the gate of  $Q_1$  it turns off and removes the base drive from  $Q_2$ . This results in a high voltage or open switch condition at the collector of  $Q_2$ . When the input voltage exceeds the reference voltage, the LM4250 output goes to +9.5V causing  $D_1$  to be reverse biased.  $Q_1$  turns on as does  $Q_2$ , and the collector of  $Q_2$  drops to approximately 1V while sinking the 500 mA of load current.

The load denoted as  $Z_L$  can be resistor, relay coil, or indicator lamp as required; but the load current should not exceed 500 mA. For  $V^+$  values of less than 15V and  $I_L$  values of less than 25 mA both  $Q_2$  and  $R_2$  may be omitted. With only the 2N4860 JFET as an output device the circuit is still capable of driving most common types of indicator lamps.

## 11 IC Meter Amplifier Runs on Two Flashlight Batteries

Meter amplifiers normally require one or two 9V transistor batteries. Due to the heavy current drain on these supplies, the meters must be switched to the OFF position when not in use. The meter circuit described here operates on two 1.5V flashlight batteries and has a quiescent power drain so low that no ON-OFF switch is needed. A pair of Eveready No. 950 "D" cells will serve for a minimum of one year without replacement. As a DC ammeter, the circuit will provide current ranges as low as 100 nA full-scale.

The basic meter amplifier circuit shown in Figure 12 is a current-to-voltage converter. Negative feedback around the amplifier insures that currents  $I_{IN}$  and  $I_f$  are always equal, and the high gain of the op amp insures that the input voltage between Pins 2 and 3 is in the microvolt region. Output

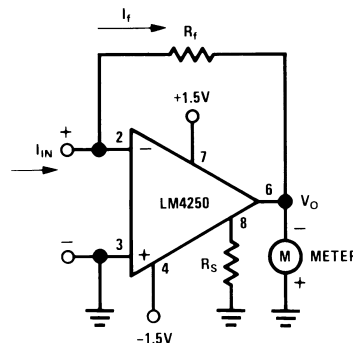

Figure 12. Basic Meter Amplifier

voltage  $V_o$  is therefore equal to  $-I_f R_f$ . Considering the  $\pm 1.5V$  sources ( $\pm 1.2V$  end-of-life) a practical value of  $V_o$  for full scale meter deflection is 300 mV. With the master bias-current setting resistor ( $R_s$ ) set at 10 M $\Omega$ , the total quiescent current drain of the circuit is 0.6  $\mu A$  for a total power supply drain of 1.8  $\mu W$ . The input bias current, required by the amplifier at this low level of quiescent current, is in the range of 600 pA.

## 12 The Complete Nanoammeter

The complete meter amplifier shown in Figure 13 is a differential current-to-voltage converter with input protection, zeroing and full scale adjust provisions, and input resistor balancing for minimum offset voltage. Resistor  $R'_f$  (equal in value to  $R_f$  for measurements of less than 1  $\mu A$ ) insures that the input bias currents for the two input terminals of the amplifier do not contribute significantly to an output error voltage. The output voltage  $V_o$  for the differential current-to-voltage converter is equal to  $-2 I_f R_f$  since the floating input current  $I_{IN}$  must flow through  $R_f$  and  $R'_f$ .  $R'_f$  may

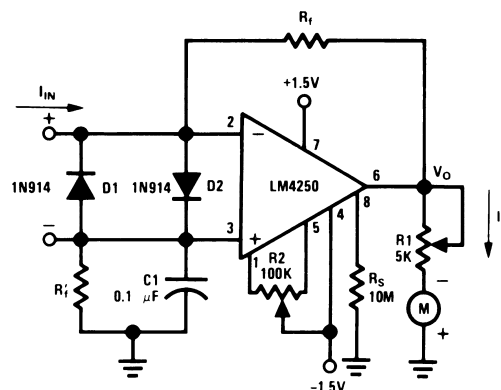

Figure 13. Complete Meter Amplifier

**Table 1. Resistance Values for DC Nano and Micro Ammeter**

I FULL SCALE	$R_f$ [ $\Omega$ ]	$R'_f$ [ $\Omega$ ]
100 nA	1.5M	1.5M
500 nA	300k	300k
1 $\mu$ A	300k	0
5 $\mu$ A	60k	0
10 $\mu$ A	30k	0
50 $\mu$ A	6k	0
100 $\mu$ A	3k	0

be omitted for  $R_f$  values of 500 k $\Omega$  or less, since a resistance of this value contributes an error of less than 0.1% in output voltage. Potentiometer  $R_2$  provides an electrical meter zero by forcing the input offset voltage  $V_{os}$  to zero. Full scale meter deflection is set by  $R_1$ . Both  $R_1$  and  $R_2$  only need to be set once for each op amp and meter combination. For a 50 microamp 2 k $\Omega$  meter movement,  $R_1$  should be about 4 k $\Omega$  to give full scale meter deflection in response to a 300 mV output voltage. Diodes  $D_1$  and  $D_2$  provide full input protection for overcurrents up to 75 mA.

With an  $R_f$  resistor value of 1.5M the circuit in Figure 13 becomes a nanometer with a full scale reading capability of 100 nA. Reducing  $R_f$  to 3 k $\Omega$  in steps, as shown in Figure 13 increases the full scale deflection to 100  $\mu$ A, the maximum for this circuit configuration. The voltage drop across the two input terminals is equal to the output voltage  $V_o$  divided by the open loop gain. Assuming an open loop gain of 10,000 gives an input voltage drop of 30  $\mu$ V or less.

### 13 Circuit for Higher Current Readings

For DC current readings higher than 100  $\mu$ A, the inverting amplifier configuration shown in Figure 14 provides the required gain. Resistor  $R_A$  develops a voltage drop in response to input current  $I_A$ . This voltage is amplified by a factor equal to the ratio of  $R_f/R_B$ .  $R_B$  must be sufficiently larger than  $R_A$ , so as not to load the input signal. Figure 14 also shows the proper values of  $R_A$ ,  $R_B$  and  $R_f$  for full scale meter deflections of from 1 mA to 10A.

**Table 2. Resistance Values for DC Ammeter**

I FULL SCALE	$R_A$ [ $\Omega$ ]	$R_B$ [ $\Omega$ ]	$R_f$ [ $\Omega$ ]
1 mA	3.0	3k	300k
10 mA	.3	3k	300k
100 mA	.3	30k	300k
1A	.03	30k	300k
10A	.03	30k	30k

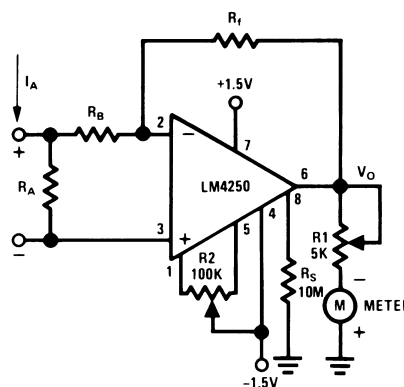

**Figure 14. Ammeter**

## 14 A 10 mV to 100V Full-Scale Voltmeter

A resistor inserted in series with one of the input leads of the basic meter amplifier converts it to a wide range voltmeter circuit, as shown in Figure 15. This inverting amplifier has a gain varying from  $-30$  for the 10 mV full scale range to  $-0.003$  for the 100V full scale range. Figure 15 also lists the proper values of  $R_v$ ,  $R_f$ , and  $R'_f$  for each range. Diodes  $D_1$  and  $D_2$  provide complete amplifier protection for input overvoltages as high as 500V on the 10 mV range, but if overvoltages of this magnitude are expected under continuous operation, the power rating of  $R_v$  should be adjusted accordingly.

**Table 3. Resistance Values for a DC Voltmeter**

V FULL SCALE	$R_v$ [ $\Omega$ ]	$R_f$ [ $\Omega$ ]	$R'_f$ [ $\Omega$ ]
10 mV	100k	1.5M	1.5M
100 mV	1M	1.5M	1.5M
1V	10M	1.M	1.5M
10V	10M	300k	0
100V	10M	30k	0

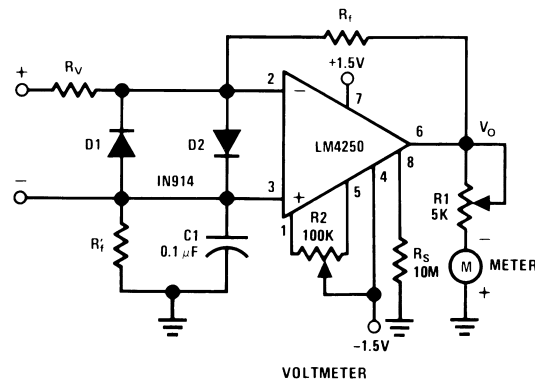

**Figure 15. Voltmeter**

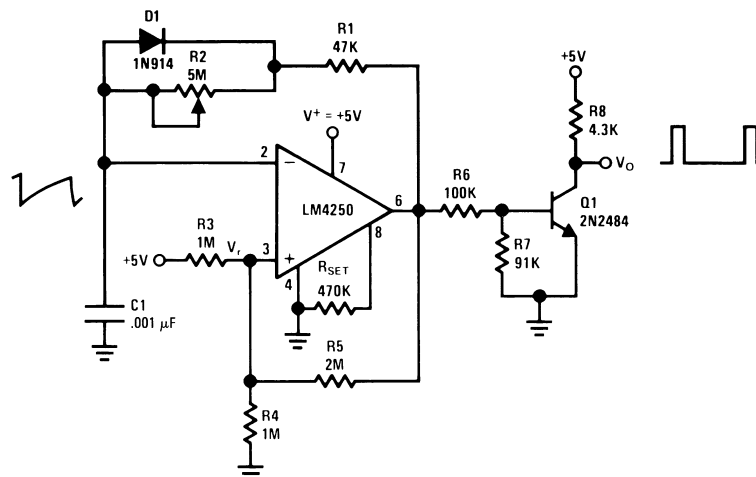

**Figure 16. Pulse Generator**

## 15 Low Frequency Pulse Generator Using a Single +5V Supply

The variable frequency pulse generator shown in Figure 16 provides an example of the LM4250 operated from a single supply. The circuit is a buffered output free running multivibrator with a constant width output pulse occurring with a frequency determined by potentiometer  $R_2$ .

The LM4250 acts as a comparator for the voltages found at the upper plate of capacitor  $C_1$  and at the reference point denoted as  $V_r$  on Figure 16. Capacitor  $C_1$  charges and discharges with a peak-to-peak amplitude of approximately 1V determined by the shift in reference voltage  $V_r$  at Pin 3 of the op amp. The charge path of  $C_1$  is from the amplifier output, which is at its maximum positive voltage  $V_{HIGH}$  (approximately  $V^+ - 0.5V$ ), through  $R_1$  and through the potentiometer  $R_2$ . Diode  $D_1$  is reverse biased during the charge period. When  $C_1$  charges to the  $V_r$  value determined by the net result of  $V_{HIGH}$  through resistor  $R_5$  and  $V^+$  through the voltage divider made up of resistors  $R_3$  and  $R_4$  the amplifier swings to its lower limit of approximately 0.5V causing  $C_1$  to begin discharging. The discharge path is through the forward biased diode  $D_1$ , through resistor  $R_1$ , and into Pin 6 of the op amp. Since the impedance in the discharge path does not vary for  $R_2$  settings of from 3 k $\Omega$  to 5 M $\Omega$ , the output pulse maintains a constant pulse width of 41  $\mu s \pm 1.5 \mu s$  over this range of potentiometer settings. Figure 17 shows the output pulse frequency variation from 6 kHz down to 360 Hz as  $R_2$  places from 100 k $\Omega$  up to 5 M $\Omega$  of additional resistance in the charge path of  $C_1$ . Setting  $R_2$  to zero ohms will short out diode  $D_1$  and cause a symmetrical square wave output at a frequency of 10 kHz. Increasing the value of  $C_1$  will lower the range of frequencies available in response to the  $R_2$  variation shown on Figure 17. Electrolytic capacitors may be used for the larger values of  $C_1$  since it has only positive voltages applied to it.

The output buffer  $Q_1$  presents a constant load to the op amp output thereby preventing frequency variations caused by  $V_{HIGH}$  and  $V_{LOW}$  voltages changing as a function of load current. The output of  $Q_1$  will interface directly with a standard TTL or DTL logic device. Reversing diode  $D_1$  will invert the polarity of the generator output providing a series of negative going pulses dropping from +5V to the saturation voltage of  $Q_1$ .

The change in output frequency as a function of supply voltage is less than  $\pm 4\%$  for a  $V^+$  change of from 4V to 10V. This stability of frequency versus supply voltage is due to the fact that the reference voltage  $V_r$  and the drive voltage for the capacitor are both direct functions of  $V^+$ .

The power dissipation of the free running multivibrator is 300  $\mu W$  and the power dissipation of the buffer circuit is approximately 5.8 mW.

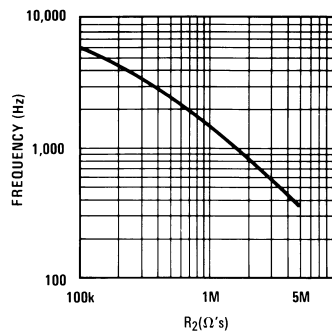
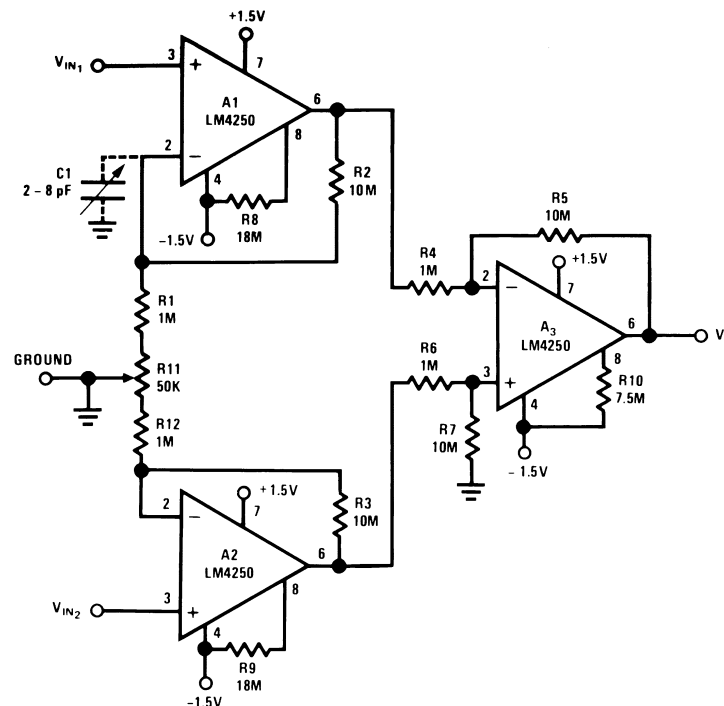

Figure 17. Pulse Frequency vs  $R_2$

**Notes:**

Quiescent  $P_D = 10 \mu W$

R2, R3, R4, R5, R6 and R7 are 1% resistors

R11 and C1 are for DC and AC common mode rejection adjustments

**Figure 18. x 100 Instrumentation Amplifier**

## 16 X100 Instrumentation Amplifier

The instrumentation amplifier circuit shown in [Figure 18](#) has a full differential input center tapped to ground. With the bias current set at approximately  $0.1 \mu A$ , the impedance looking into either  $V_{IN1}$  or  $V_{IN2}$  is  $100 M\Omega$  with respect to ground, and the input bias current at either terminal is  $0.2 nA$ . The two non-inverting input stages  $A_1$  and  $A_2$  apply a gain of 10 to the input signal, and the differential output stage  $A_3$  applies an additional gain of  $-10$  for a net amplifier gain of  $-100$ :

$$V_O = -100(V_{IN1} - V_{IN2}). \quad (16)$$

The entire circuit can run from two 1.5V batteries connected directly (no power switch) to the  $V^+$  and  $V^-$  terminals. With a total current drain of  $2.8 \mu A$  the quiescent power dissipation of the circuit is  $8.4 \mu W$ . This is low enough to have no significant effect on the shelf life of most batteries.

Potentiometer  $R_{11}$  provides a means for matching the gains of  $A_1$  and  $A_2$  to achieve maximum DC common mode rejection ratio CMRR. With  $R_{11}$  adjusted to its null point for DC common mode rejection the small AC CMRR trimmer capacitor  $C_1$  will normally give an additional 10 to 20 dB of CMRR over the operating frequency range. Since  $C_1$  actually balances wiring capacitance rather than amplifier frequency characteristics, it may be necessary to attach it to Pin 2 of either  $A_1$  or  $A_2$  as required. [Figure 19](#) shows the variation of CMRR (referred to the input) with frequency for this configuration. Since the circuit applies a gain of 100 or 40 dB to an input signal, the actual observed rejection ratio

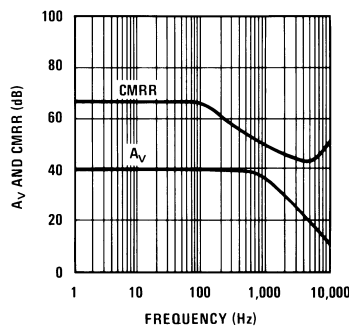

**Figure 19. A<sub>V</sub> and CMRR vs Frequency**

is the difference between the CMRR curve and A<sub>V</sub> curve. For example, a 60 Hz common mode signal will be attenuated by 67 dB minus 40 dB or 27 dB for an actual rejection ratio of  $V_{IN}/V_O$  equal to 22.4.

The maximum peak-to-peak output signal into a 100 kΩ load resistor is approximately 1.8V. With no input signal, the noise seen at the output is approximately 0.8 mV<sub>RMS</sub> or 8 μV<sub>RMS</sub> referred to the input. When doing power dissipation measurements on this circuit, it should be kept in mind that even a 1 MΩ oscilloscope probe placed between +1.5V and -1.5V will more than double the power drawn from the batteries.

## 17 5V Regulator for Cmos Logic Circuits

The ideal regulator for low power CMOS logic elements should dissipate essentially no power when the CMOS devices are running at low frequencies, but be capable of delivering full output power on demand when the CMOS devices are running in the 0.1 MHz to 10 MHz region. With a 10V input voltage, the regulator shown in Figure 20 will dissipate 350 μW in the stand-by mode but will deliver up to 50 mA of continuous load current when required.

The circuit is basically a boosted output voltage-follower referenced to a low current zener diode. The voltage divider consisting of R<sub>2</sub> and R<sub>3</sub> provides a 5V tap voltage from the 6.5V reference diode to determine the regulator output. Since a standard 6.5V zener diode does not exhibit good regulation in the 2 μA to 60 μA reverse current region, Q<sub>2</sub> must be a special device. An NPN transistor with its collector and base terminals grounded and its emitter tied to the junction of R<sub>1</sub> and R<sub>2</sub> exhibits a well-controlled base emitter reverse breakdown voltage. A National Semiconductor process 25 small signal NPN transistor sorted to a 2N registration such as 2N3252 has a BV<sub>EBO</sub> at 10 μA specified as 5.5V minimum, 6.5V typical, and 7.0V maximum. Using a diode connected 2N3252 as a reference, the regulator output voltage changed 78 mV in response to an 8V to 36V change in the input voltage. This test was done under both no load and full load conditions and represents a line regulation of better than 1.6%.

A load change from 10 μA to 50 mA caused a 1 mV change in output voltage giving a load regulation value of 0.05%. When operating the regulator at load currents of less than 25 mA, no heat sink is required for Q<sub>1</sub>. For load currents in excess of 50 mA, Q<sub>1</sub> should be replaced by a Darlington pair with the 2N3019 acting as a driver for a higher power device such as a 2N3054.

## 18 References

Millman, J. and Halkias, C.C.: "Electronic Device and Circuits," pp. 465–466, McGraw-Hill Book Company, New York, 1967.

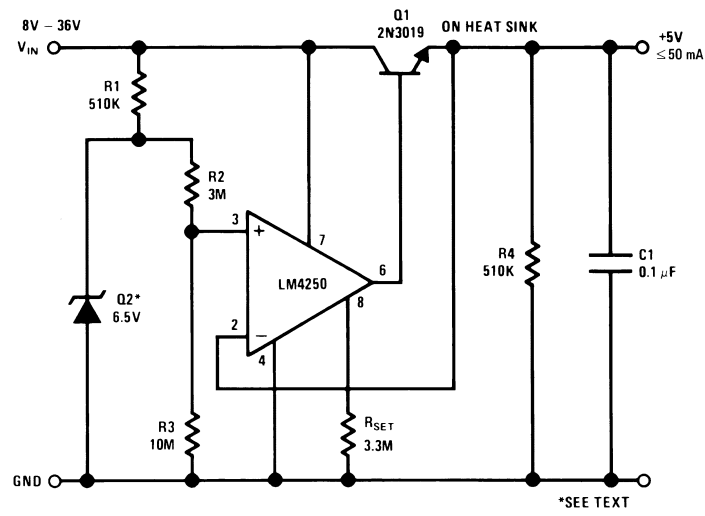

Figure 20. 350 µW Quiescent Drain 5 Volt Regulator



## IMPORTANT NOTICE

Texas Instruments Incorporated and its subsidiaries (TI) reserve the right to make corrections, enhancements, improvements and other changes to its semiconductor products and services per JESD46, latest issue, and to discontinue any product or service per JESD48, latest issue. Buyers should obtain the latest relevant information before placing orders and should verify that such information is current and complete. All semiconductor products (also referred to herein as "components") are sold subject to TI's terms and conditions of sale supplied at the time of order acknowledgment.

TI warrants performance of its components to the specifications applicable at the time of sale, in accordance with the warranty in TI's terms and conditions of sale of semiconductor products. Testing and other quality control techniques are used to the extent TI deems necessary to support this warranty. Except where mandated by applicable law, testing of all parameters of each component is not necessarily performed.

TI assumes no liability for applications assistance or the design of Buyers' products. Buyers are responsible for their products and applications using TI components. To minimize the risks associated with Buyers' products and applications, Buyers should provide adequate design and operating safeguards.

TI does not warrant or represent that any license, either express or implied, is granted under any patent right, copyright, mask work right, or other intellectual property right relating to any combination, machine, or process in which TI components or services are used. Information published by TI regarding third-party products or services does not constitute a license to use such products or services or a warranty or endorsement thereof. Use of such information may require a license from a third party under the patents or other intellectual property of the third party, or a license from TI under the patents or other intellectual property of TI.

Reproduction of significant portions of TI information in TI data books or data sheets is permissible only if reproduction is without alteration and is accompanied by all associated warranties, conditions, limitations, and notices. TI is not responsible or liable for such altered documentation. Information of third parties may be subject to additional restrictions.

Resale of TI components or services with statements different from or beyond the parameters stated by TI for that component or service voids all express and any implied warranties for the associated TI component or service and is an unfair and deceptive business practice. TI is not responsible or liable for any such statements.

Buyer acknowledges and agrees that it is solely responsible for compliance with all legal, regulatory and safety-related requirements concerning its products, and any use of TI components in its applications, notwithstanding any applications-related information or support that may be provided by TI. Buyer represents and agrees that it has all the necessary expertise to create and implement safeguards which anticipate dangerous consequences of failures, monitor failures and their consequences, lessen the likelihood of failures that might cause harm and take appropriate remedial actions. Buyer will fully indemnify TI and its representatives against any damages arising out of the use of any TI components in safety-critical applications.

In some cases, TI components may be promoted specifically to facilitate safety-related applications. With such components, TI's goal is to help enable customers to design and create their own end-product solutions that meet applicable functional safety standards and requirements. Nonetheless, such components are subject to these terms.

No TI components are authorized for use in FDA Class III (or similar life-critical medical equipment) unless authorized officers of the parties have executed a special agreement specifically governing such use.

Only those TI components which TI has specifically designated as military grade or "enhanced plastic" are designed and intended for use in military/aerospace applications or environments. Buyer acknowledges and agrees that any military or aerospace use of TI components which have **not** been so designated is solely at the Buyer's risk, and that Buyer is solely responsible for compliance with all legal and regulatory requirements in connection with such use.

TI has specifically designated certain components which meet ISO/TS16949 requirements, mainly for automotive use. Components which have not been so designated are neither designed nor intended for automotive use; and TI will not be responsible for any failure of such components to meet such requirements.

### Products

Audio	<a href="http://www.ti.com/audio">www.ti.com/audio</a>
Amplifiers	<a href="http://amplifier.ti.com">amplifier.ti.com</a>
Data Converters	<a href="http://dataconverter.ti.com">dataconverter.ti.com</a>
DLP® Products	<a href="http://www.dlp.com">www.dlp.com</a>
DSP	<a href="http://dsp.ti.com">dsp.ti.com</a>
Clocks and Timers	<a href="http://www.ti.com/clocks">www.ti.com/clocks</a>
Interface	<a href="http://interface.ti.com">interface.ti.com</a>
Logic	<a href="http://logic.ti.com">logic.ti.com</a>
Power Mgmt	<a href="http://power.ti.com">power.ti.com</a>
Microcontrollers	<a href="http://microcontroller.ti.com">microcontroller.ti.com</a>
RFID	<a href="http://www.ti-rfid.com">www.ti-rfid.com</a>
OMAP Applications Processors	<a href="http://www.ti.com/omap">www.ti.com/omap</a>
Wireless Connectivity	<a href="http://www.ti.com/wirelessconnectivity">www.ti.com/wirelessconnectivity</a>

### Applications

Automotive and Transportation	<a href="http://www.ti.com/automotive">www.ti.com/automotive</a>
Communications and Telecom	<a href="http://www.ti.com/communications">www.ti.com/communications</a>
Computers and Peripherals	<a href="http://www.ti.com/computers">www.ti.com/computers</a>
Consumer Electronics	<a href="http://www.ti.com/consumer-apps">www.ti.com/consumer-apps</a>
Energy and Lighting	<a href="http://www.ti.com/energy">www.ti.com/energy</a>
Industrial	<a href="http://www.ti.com/industrial">www.ti.com/industrial</a>
Medical	<a href="http://www.ti.com/medical">www.ti.com/medical</a>
Security	<a href="http://www.ti.com/security">www.ti.com/security</a>
Space, Avionics and Defense	<a href="http://www.ti.com/space-avionics-defense">www.ti.com/space-avionics-defense</a>
Video and Imaging	<a href="http://www.ti.com/video">www.ti.com/video</a>

### TI E2E Community

[e2e.ti.com](http://e2e.ti.com)