

# ***PDHengineer.com***

**Course N<sup>o</sup> IC-4001**

## **Fiber Optics (Volume 1) - Theory**

This document is the course text. You may review this material at your leisure before or after you purchase the course. If you have not already purchased the course, you may do so now by returning to the course overview page located at:

<http://www.pdhengineer.com/pages/IC-4001.htm>  
(Please be sure to capitalize and use dash as shown above.)

Once the course has been purchased, you can easily return to the course overview, course document and quiz from PDHengineer's My Account menu.

If you have any questions or concerns, remember you can contact us by using the Live Support Chat link located on any of our web pages, by email at [administrator@PDHengineer.com](mailto:administrator@PDHengineer.com) or by telephone toll-free at 1-877-PDHengineer.

Thank you for choosing PDHengineer.com.



17350 State Highway 249 | Suite 140 | Houston, TX 77064

Fiber Optics  
Volume I  
Theory

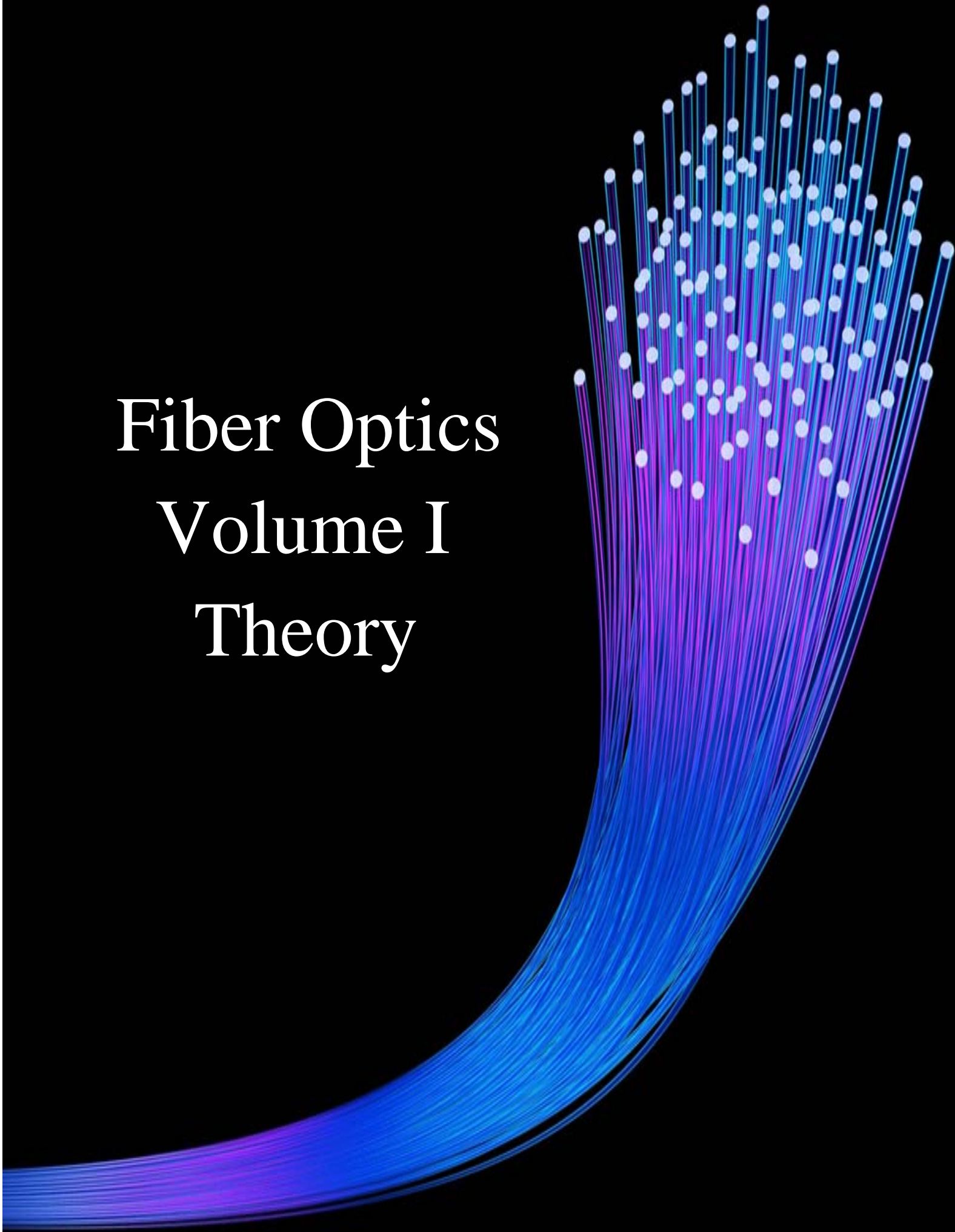

## Table of Contents

<u>Section</u>	<u>Page</u>
Preface .....	3
Introduction .....	4
Chapter 1 – Transmission of Light .....	9
Chapter 2 – Transmission through Fiber..	16
Chapter 3 – Optical Fiber types.....	30
Summary .....	39

This series of courses are based on the Navy Electricity and Electronics Training Series (NEETS) section on Fiber Optic cable systems. The NEETS material has been reformatted for readability and ease of use as a continuing education course. The NEETS series is produced by the Naval Education and Training Professional Development and Technology Center.

## Preface

This is the first in a series of five courses about fiber optic cable systems. The series covers fiber optics from basic light theory transmission to cables, connectors, testing, and signal transmission.

The complete series includes these five courses:

1. Fiber Optics I – Theory
2. Fiber Optics II – Cable Design
3. Fiber Optics III – Connectors
4. Fiber Optics IV – Testing
5. Fiber Optics V – Equipment

The first course, *Fiber Optics I – Theory*, is an overview of the technology of fiber optic cables including a description of the components, history, and advantages of fiber optic cables. This course also discusses the electromagnetic theory of light and describes the properties of light reflection, refraction, diffusion, and absorption.

The second course, *Fiber Optics II - Cable Design*, explains the basic construction of fiber optic cables including the types of cables, cable properties, and performance characteristics. The course reviews multimode, single mode step-index and graded index fibers, and fabrication procedures.

The third course, *Fiber Optics III - Connectors*, describes fiber optic splices, connectors, couplers and the types of connections they form in systems. It includes a discussion on the types of extrinsic and intrinsic coupling losses, fiber alignment and fiber mismatch problems, and fiber optic mechanical and fusion splices.

The fourth course, *Fiber Optics IV - Testing*, describes the optical fiber and optical connection laboratory measurements used to evaluate fiber optic components and system performance, including the near-field and far-field optical power distribution of an optical fiber. This course also reviews optical time-domain reflectometry (OTDR).

The fifth course, *Fiber Optics V - Equipment*, explains the principal properties of an optical source and fiber optic transmitters, the optical emission properties of semiconductor light-emitting diodes (LEDs) and laser diodes (LDs), and explains the operational differences between surface-emitting LEDs (SLEDs), edge-emitting LEDs (ELEDs), superluminescent diodes (SLDs), and laser diodes.

It is not necessary to take the courses in sequence. However, for best comprehension it is suggested that the courses be taken in the order presented.

## Introduction

Electrical systems include telephone, radio, cable television (CATV), radar, and satellite links. In the past 30 years, researchers have developed a new technology that offers greater data rates over longer distances at costs lower than copper wire systems. This technology is fiber optics.

Fiber optics uses light to send information (data). More formally, *fiber optics* is the branch of optical technology concerned with the transmission of radiant power (light energy) through fibers.

### Overview

A fiber optic data link sends input data through fiber optic components and provides this data as output information. It has the following three basic functions:

- To convert an electrical input signal to an optical signal
- To send the optical signal over an optical fiber
- To convert the optical signal back to an electrical signal

A fiber optic data link consists of three parts - transmitter, optical fiber, and receiver. Figure 1 is an illustration of a fiber optic data-link connection. The transmitter, optical fiber, and receiver perform the basic functions of the fiber optic data link. Each part of the data link is responsible for the successful transfer of the data signal.

A fiber optic data link needs a transmitter that can effectively convert an electrical input signal to an optical signal and launch the data-containing light down the optical fiber. A fiber optic data link also needs a receiver that can effectively transform this optical signal back into its original form. This means that the electrical signal provided as data output should exactly match the electrical signal provided as data input.

Figure 1. - Parts of a fiber optic data link.

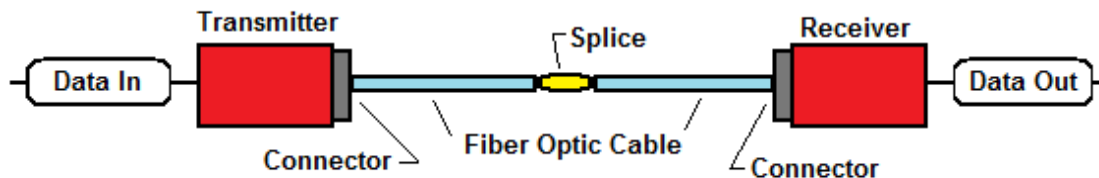

The transmitter converts the input signal to an optical signal suitable for transmission. The transmitter consists of two parts, an interface circuit and a source drive circuit. The transmitter's drive circuit converts the electrical signals to an optical signal. It does this by varying the current flow through the light source. The two types of optical sources are light-emitting diodes (LEDs) and laser diodes.

The optical source launches the optical signal into the fiber. The optical signal will become progressively weakened and distorted because of scattering, absorption, and dispersion mechanisms in the fiber waveguides.

The receiver converts the optical signal exiting the fiber back into an electrical signal. The receiver consists of two parts, the optical detector and the signal-conditioning circuits. An optical detector detects the optical signal. The signal-conditioning circuit conditions the detector output so that the receiver output matches the original input to the transmitter. The receiver should amplify and process the optical signal without introducing noise or signal distortion. Noise is any disturbance that obscures or reduces the quality of the signal. Noise effects and limitations of the signal-conditioning circuits cause the distortion of the receiver's electrical output signal.

An optical detector can be either a semiconductor positive-intrinsic-negative (*PIN*) diode or an avalanche photodiode (APD).

A *PIN* diode changes its electrical conductivity according to the intensity and wavelength of light. The *PIN* diode consists of an intrinsic region between p-type and n-type semiconductor material.

A fiber optic data link also includes passive components other than an optical fiber. Figure 1 does not show the optical connections used to complete the construction of the fiber optic data link. Passive components used to make fiber connections affect the performance of the data link. These components can also prevent the link from operating. Fiber optic components used to make the optical connections include optical splices, connectors, and couplers.

Proof of link performance is an integral part of the design, fabrication, and installation of any fiber optic system. Various measurement techniques are used to test individual parts of a data link. Each data link part is tested to be sure the link is operating properly.

## **History**

People have used light to transmit information for hundreds of years. However, it was not until the 1960s, with the invention of the laser that widespread interest in optical (light) systems for data communications began. The invention of the laser prompted researchers to study the potential of fiber optics for data communications, sensing, and other applications. Laser systems could send a much larger amount of data than telephone, microwave, and other electrical systems. The first experiment with the laser involved letting the laser beam transmit freely through the air. Researchers also conducted experiments letting the laser beam transmit through different types of waveguides. Glass fibers, gas-filled pipes, and tubes with focusing lenses are examples of optical waveguides. Glass fibers soon became the preferred medium for fiber optic research.

Initially, the very large losses in the optical fibers prevented coaxial cables from being replaced. Loss is the decrease in the amount of light reaching the end of the fiber. Early fibers had losses around 1,000 dB/km making them impractical for communications use. In 1969, several scientists concluded that impurities in the fiber material caused the signal loss in optical fibers.

The basic fiber material did not prevent the light signal from reaching the end of the fiber. These researchers believed it was possible to reduce the losses in optical fibers by removing the impurities. By removing the impurities, construction of low-loss optical fibers was possible.

There are two basic types of optical fibers, multimode fibers and single mode fibers. The types of fiber designs are covered in Volume II – Cable Design.

In 1970, Corning Glass Works made a multimode fiber with losses under 20 dB/km.

This same company, in 1972, made a high silica-core multimode optical fiber with 4dB/km minimum attenuation (loss). Currently, multimode fibers can have losses as low as 0.5 dB/km at wavelengths around 1300 nm. Single mode fibers are available with losses lower than 0.25 dB/km at wavelengths around 1500 nm.

Developments in semiconductor technology, which provided the necessary light sources and detectors, furthered the development of fiber optics. Conventional light sources, such as lamps or lasers, were not easily used in fiber optic systems. These light sources tended to be too large and required lens systems to launch light into the fiber. In 1971, Bell Laboratories developed a small area light-emitting diode (LED). This light source was suitable for low-loss coupling to optical fibers. Researchers could then perform source-to-fiber jointing easily and repeatedly. Early semiconductor sources had operating lifetimes of only a few hours. However, by 1973, projected lifetimes of lasers advanced from a few hours to greater than 1,000 hours. By 1977, projected lifetimes of lasers advanced to greater than 7,000 hours. By 1979, these devices were available with projected lifetimes of more than 100,000 hours.

In addition, researchers also continued to develop new fiber optic parts. The types of new parts developed included low-loss fibers and fiber cables, splices, and connectors. These parts permitted demonstration and research on complete fiber optic systems.

Advances in fiber optics have permitted the introduction of fiber optics into present applications. These applications are mostly in the telephone long-haul systems, but are growing to include cable television, computer networks, video systems, and data links. Research should increase system performance and provide solutions to existing problems in conventional applications. The impressive results from early research show there are many advantages offered by fiber optic systems.

### **Fiber Optic Applications**

System design has centered on long-haul communications and the subscriber-loop plant. The subscriber-loop plant is the part of a system that connects a subscriber – or customer - to the nearest switching center. Cable television is an example. Limited work has also been done on short-distance applications.

Initially, central office trunking required multimode optical fibers with moderate to good performance. Fiber performance depends on the amount of loss and signal distortion introduced by the fiber when it is operating at a specific wavelength. Long-haul systems require single mode

optical fibers with very high performance. Single mode fibers tend to have lower loss and produce less signal distortion.

In contrast, short-distance systems tend to use only multimode technology. Examples of short-distance systems include process control and local area networks (LANs). Short-distance systems have many connections. The larger fiber core and higher fiber numerical aperture (NA) of multimode fibers reduce losses at these connections.

In subscriber-loop applications, system design and parts selection are related. Designers consider trade-offs in the following areas:

- Fiber properties
- Types of connections
- Optical sources
- Detector types

Designers develop systems to meet stringent working requirements, while trying to maintain economic performance. It is quite difficult to identify a standard system design approach.

Future system design improvements depend on continued research. Researchers expect fiber optic product improvements to upgrade performance and lower costs for short-distance applications. Future systems center on broadband services that will allow transmission of voice, video, and data. Services will include television, data retrieval, video word processing, electronic mail, banking, and shopping.

### **Advantages and Disadvantages of Fiber Optics**

Fiber optic systems have many attractive features that are superior to electrical systems. These include improved system performance, immunity to electrical noise, signal security, and improved safety and electrical isolation.

Other advantages include reduced size and weight, environmental protection, and overall system economy. The main advantages of fiber optic systems include,

- System Performance
- Greatly increased bandwidth and capacity
- Lower signal attenuation (loss)
- Immunity to Electrical Noise
- Immune to noise
- No crosstalk
- Lower bit error rates
- Signal Security
- Difficult to tap
- Nonconductive Electrical Isolation
- No common ground required
- Freedom from short circuit and sparks



- Size and Weight
- Reduced size and weight cables
- Environmental Protection
- Resistant to radiation and corrosion
- Resistant to temperature variations
- Improved ruggedness and flexibility
- Less restrictive in harsh environments
- Overall System Economy
- Low per-channel cost
- Lower installation cost

Despite the many advantages of fiber optic systems, there are some disadvantages.

Because of the relative newness of the technology, fiber optic components are expensive. Fiber optic transmitters and receivers are still relatively expensive compared to electrical interfaces. The lack of standardization in the industry has also limited the acceptance of fiber optics. Many industries are more comfortable with the use of electrical systems and are reluctant to switch to fiber optics. However, industry researchers are eliminating these disadvantages.

In the next three chapters we will look at the properties of light, how light is transmitted through optical fibers, and the types of optical fibers.

# Chapter 1

## Transmission of Light

Fiber optics deals with the transmission of light energy through transparent fibers. How an optical fiber guides light depends on the nature of the light and the structure of the optical fiber. A light wave is a form of energy that is moved by wave motion. Wave motion can be defined as a recurring disturbance advancing through space with or without the use of a physical medium. In fiber optics, wave motion is the movement of light energy through an optical fiber.

Before we introduce the subject of light transmission through optical fibers, we must first understand the nature of light and the properties of light waves.

### Light Propagation

The exact nature of light is not fully understood, although people have been studying the subject for many centuries. In the 1700s and before, experiments seemed to indicate that light was composed of particles. In the early 1800s, a physicist Thomas Young showed that light exhibited wave characteristics.

Further experiments by other physicists culminated in James Maxwell collecting the four fundamental equations that completely describe the behavior of the electromagnetic fields. James Maxwell deduced that light was simply a component of the electromagnetic spectrum. This seems to firmly establish that light is a wave. Yet, in the early 1900s, the interaction of light with semiconductor materials, called the photoelectric effect, could not be explained with electromagnetic-wave theory.

The advent of quantum physics successfully explained the photoelectric effect in terms of fundamental particles of energy called *quanta*. Quanta are known as *photons* when referring to light energy.

Today, when studying light that consists of many photons, as in propagation, that light behaves as a continuum - an electromagnetic wave. On the other hand, when studying the interaction of light with semiconductors, as in sources and detectors, the quantum physics approach is taken. In this course we use both the electromagnetic wave and photon concepts, each in the places where it best matches the phenomenon we are studying.

The electromagnetic energy of light is a form of electromagnetic radiation.

Light and similar forms of radiation are made up of moving electric and magnetic forces. A simple example of motion similar to these radiation waves can be made by dropping a pebble into a pool of water. In this example, the water is not actually being moved by the outward motion of the wave, but rather by the up-and-down motion of the water. The up-and-down motion is transverse, or at right angles, to the outward motion of the waves. This type of wave motion is called *transverse-wave motion*. The transverse waves spread out in expanding circles

until they reach the edge of the pool, in much the same manner as the transverse waves of light spread from the sun. However, the waves in the pool are very slow and clumsy in comparison with light, which travels approximately 186,000 miles per second.

Light radiates from its source in all directions until it is absorbed or diverted by some substance. See Figure 2, the lines drawn from the light source to any point on one of the transverse waves indicate the direction that the wavefronts are moving. These lines are called *light rays*.

Figure 2. - Light rays and wavefronts from a nearby light source.

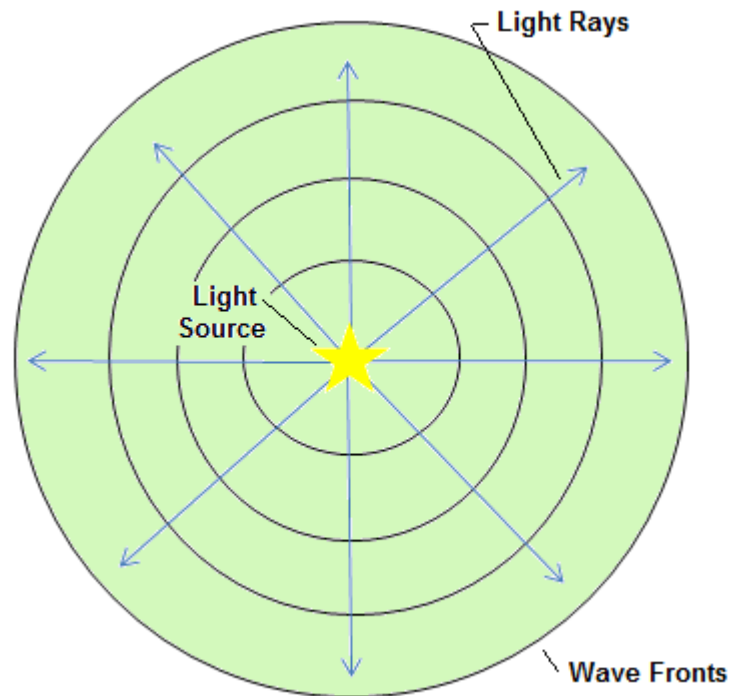

Although single rays of light typically do not exist, light rays shown in illustrations are a convenient method used to show the direction in which light is traveling at any point. A ray of light can be illustrated as a straight line.

### Light Properties

When light waves, which travel in straight lines, encounter any substance, they can be reflected, absorbed, transmitted, or refracted. This is illustrated in Figure 3. Those substances that transmit almost all the light waves falling upon them are said to be *transparent*. A transparent substance is one through which you can see clearly.

Clear glass is transparent because it transmits light rays without diffusing them, such as shown in the first image in Figure 4. There is no substance known that is perfectly transparent, but many substances are nearly so. Substances through which some light rays can pass, but through which objects cannot be seen clearly because the rays are diffused, are called *translucent* (See the

second image in Figure 4). The frosted glass of a light bulb and a piece of oiled paper are examples of translucent materials. Those substances that are unable to transmit any light rays are called *opaque* (third image in Figure 4). Opaque substances either reflect or absorb all the light rays that fall upon them.

Figure 3. - Light waves reflected, absorbed, and transmitted.

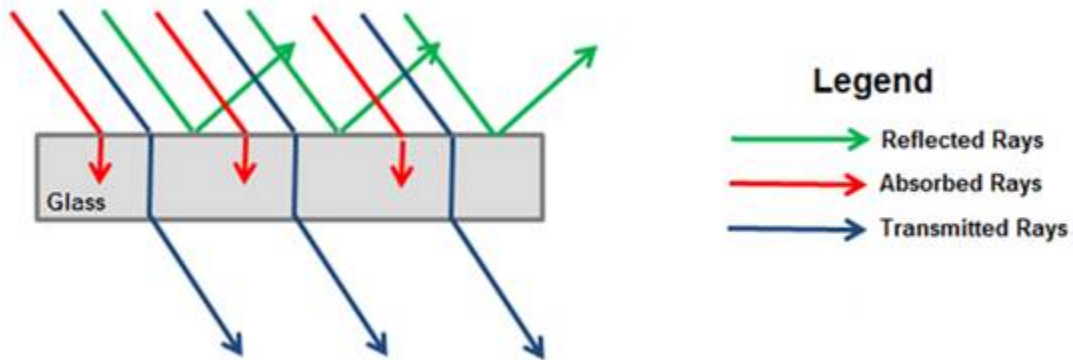
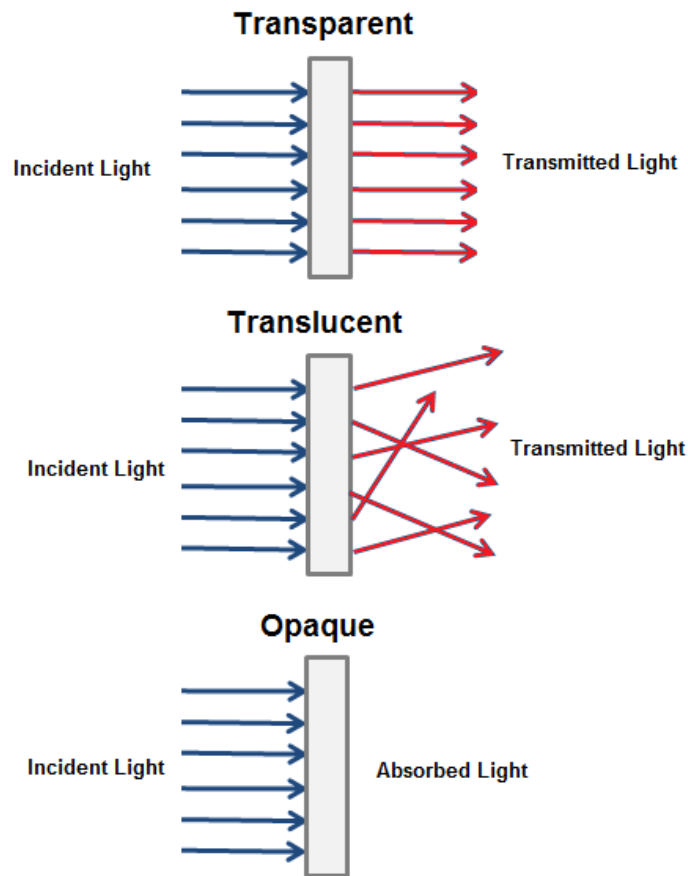

Figure 4. - Substances: Transparent; Translucent; and Opaque.



All substances that are not light sources are visible only because they reflect all or some part of the light reaching them from some luminous source.

Examples of luminous sources include the sun, a gas flame, and an electric light filament, because they are sources of light energy. If light is neither transmitted nor reflected, it is absorbed or taken up by the medium. When light strikes a substance, some absorption and some reflection always take place. No substance completely transmits, reflects, or absorbs all the light rays that reach its surface.

### Light Reflection

*Reflected waves* are simply those waves that are neither transmitted nor absorbed, but are reflected from the surface of the medium they encounter. See Figure 5, when a wave approaches a reflecting surface, such as a mirror, the wave that strikes the surface is called the *incident wave*, and the one that bounces back is called the reflected wave. An imaginary line perpendicular to the point at which the incident wave strikes the reflecting surface is called the *normal*, or the perpendicular. The angle between the incident wave and the normal is called the *angle of incidence*.

The angle between the reflected wave and the normal is called the angle of reflection.

Figure 5. - Reflection of a wave.

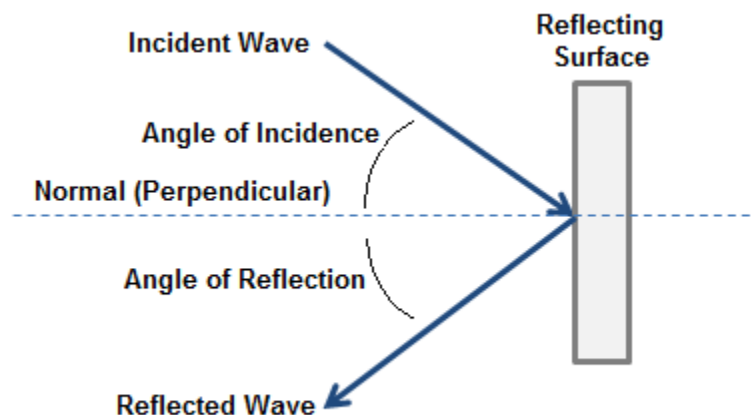

If the surface of the medium contacted by the incident wave is smooth and polished, each reflected wave will be reflected back at the same angle as the incident wave. The path of the wave reflected from the surface forms an angle equal to the one formed by its path in reaching the medium.

This conforms to the *law of reflection* which states: The angle of incidence is equal to the angle of reflection.

The amount of incident-wave energy that is reflected from a surface depends on the nature of the surface and the angle at which the wave strikes the surface. The amount of wave energy reflected increases as the angle of incidence increases. The reflection of energy is the greatest when the wave is nearly parallel to the reflecting surface. When the incidence wave is perpendicular to the surface, more of the energy is transmitted into the substance and reflection of energy is at its least. At any incident angle, a mirror reflects almost all of the wave energy, while a dull, black surface reflects very little.

Light waves obey the law of reflection. Light travels in a straight line through a substance of uniform density. For example, you can see the straight path of light rays admitted through a narrow slit into a darkened room. The straight path of the beam is made visible by illuminated dust particles suspended in the air. If the light is made to fall onto the surface of a mirror or other reflecting surface, however, the direction of the beam changes sharply.

The light can be reflected in almost any direction, depending on the angle with which the mirror is held.

### Light Refraction

When a light wave passes from one medium into a medium having a different velocity of propagation, a change in the direction of the wave will occur. This change of direction as the wave enters the second medium is called *refraction*. As in the discussion of reflection, the wave striking the boundary (surface) is called the incident wave, and the imaginary line perpendicular to the boundary is called the normal. The angle between the incident wave and the normal is called the angle of incidence. As the wave passes through the boundary, it is bent either toward or away from the normal. The angle between the normal and the path of the wave through the second medium is the *angle of refraction*.

<p><b>Velocity of Propagation</b> is the speed waves can travel through a medium.</p>
---

A light wave passing through a block of glass is shown in Figure 6. The wave moves from point A to point B at a constant speed. This is the incident wave. As the wave penetrates the glass boundary at point B, the velocity of the wave is slowed down. This causes the wave to bend toward the normal. The wave then takes the path from point B to point C through the glass and becomes both the refracted wave from the top surface and the incident wave to the lower surface. As the wave passes from the glass to the air (the second boundary), it is again refracted, this time away from the normal, and takes the path from point C to point D. After passing through the last boundary, the velocity increases to the original velocity of the wave. As illustrated, refracted waves can bend toward or away from the normal.

This bending depends on the velocity of the wave through different mediums.

The broken line between points B and E is the path that the wave would travel if the two mediums (air and glass) had the same density.

Figure 6. - Refraction of a wave.

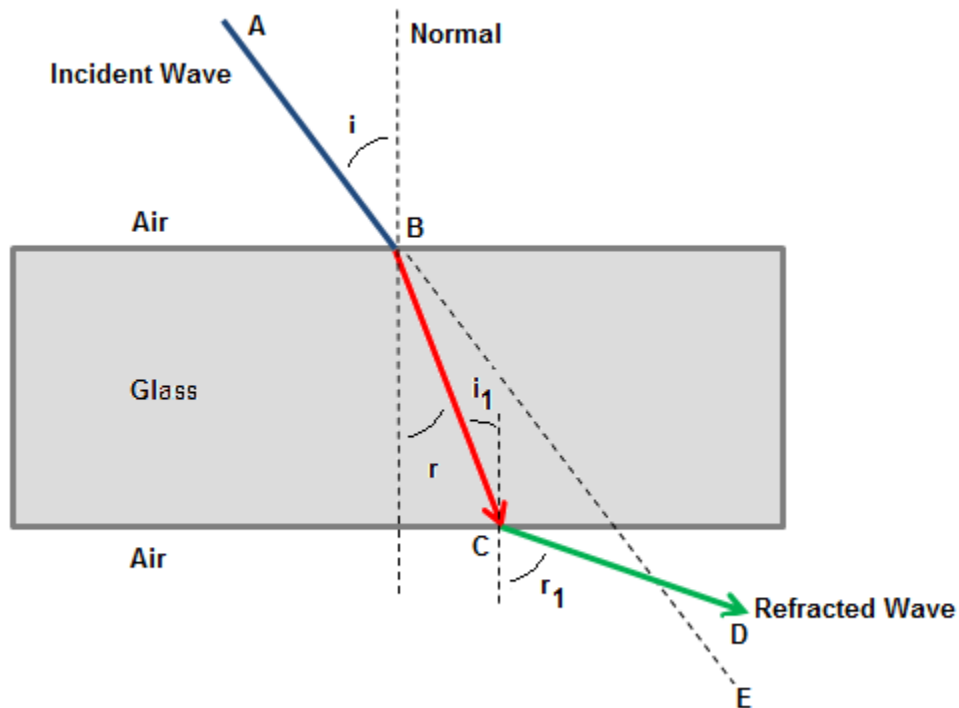

Another interesting condition can be shown using Figure 6. If the wave passes from a less dense to a denser medium, it is bent toward the normal, and the angle of refraction ( $r$ ) is less than the angle of incidence ( $i$ ). Likewise, if the wave passes from a denser to a less dense medium, it is bent away from the normal, and the angle of refraction ( $r_1$ ) is greater than the angle of incidence ( $i_1$ ).

An example of refraction is the apparent bending of a spoon when it is immersed in a cup of water. The bending seems to take place at the surface of the water, or exactly at the point where there is a change of density.

Obviously, the spoon does not bend from the pressure of the water. The light forming the image of the spoon is bent as it passes from the water (a medium of high density) to the air (a medium of comparatively low density).

Without refraction, light waves would pass in straight lines through transparent substances without any change of direction. Figure 6 shows that rays striking the glass at any angle other than perpendicular are refracted. However, perpendicular rays, which enter the glass normal to the surface, continue through the glass and into the air in a straight line - no refraction takes place.

## Light Diffusion

When light is reflected from a mirror, the angle of reflection equals the angle of incidence. When light is reflected from a piece of plain white paper; however, the reflected beam is scattered, or *diffused*, as shown in Figure 7. Because the surface of the paper is not smooth, the reflected light is broken up into many light beams that are reflected in all directions.

Figure 7. - Diffusion of light.

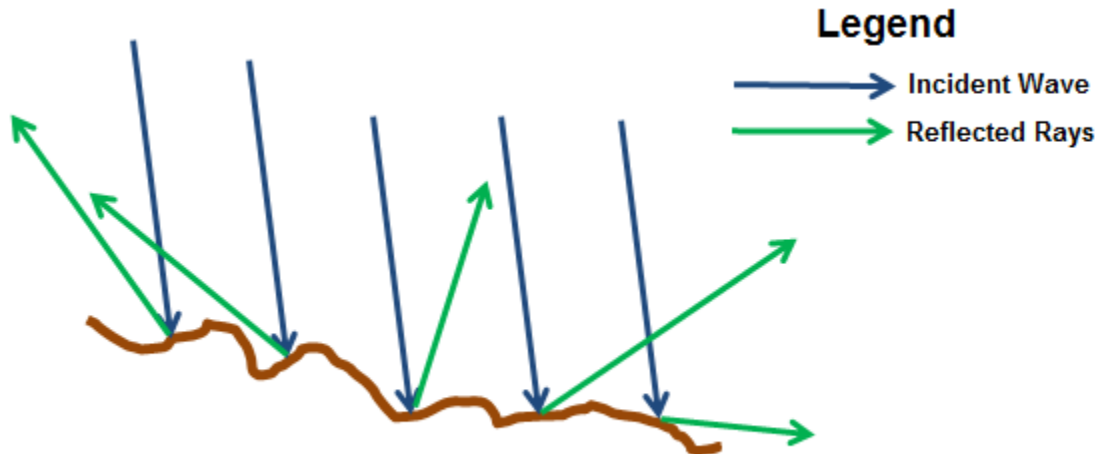

## Light Absorption

We have just seen that a light beam is reflected and diffused when it falls onto a piece of white paper. If the light beam falls onto a piece of black paper, the black paper absorbs most of the light rays and very little light is reflected from the paper.

If the surface upon which the light beam falls is perfectly black, there is no reflection; that is, the light is totally absorbed. No matter what kind of surface light falls upon, some of the light is absorbed.



## Chapter 2

### Transmission of Light through Optical Fibers

The transmission of light along optical fibers depends not only on the nature of light, but also on the structure of the optical fiber. Two methods are used to describe how light is transmitted along the optical fiber. The first method, *ray theory*, uses the concepts of light reflection and refraction. The second method, *mode theory*, treats light as electromagnetic waves. We must first understand the basic optical properties of the materials used to make optical fibers. These properties affect how light is transmitted through the fiber.

#### Optical Material Properties

The basic optical property of a material, relevant to optical fibers, is the *index of refraction*. The index of refraction ( $n$ ) measures the speed of light in an optical medium. The index of refraction of a material is the ratio of the speed of light in a vacuum to the speed of light in the material itself. The speed of light ( $c$ ) in free space (vacuum) is  $3 \times 10^8$  meters per second (m/s). The speed of light is the frequency ( $f$ ) of light multiplied by the wavelength of light ( $\lambda$ ). When light enters the fiber material, the light travels slower at a speed ( $v$ ). Light will always travel slower in the fiber material than in air. The index of refraction is given by,

$$N = \frac{c}{v}$$

Where,

$n$  = Index of refraction.

$c$  = Speed of light,  $3 \times 10^8$  meters per second (m/s).

$v$  = Speed of light in the fiber material, meters/sec.

A light ray is reflected and refracted when it encounters the boundary between two different transparent mediums. For example, Figure 8 shows what happens to the light ray when it encounters the interface between glass and air. The index of refraction for glass ( $n_1$ ) is 1.50. The index of refraction for air ( $n_2$ ) is 1.00.

Figure 8. - Light reflection and refraction at a glass-air boundary.

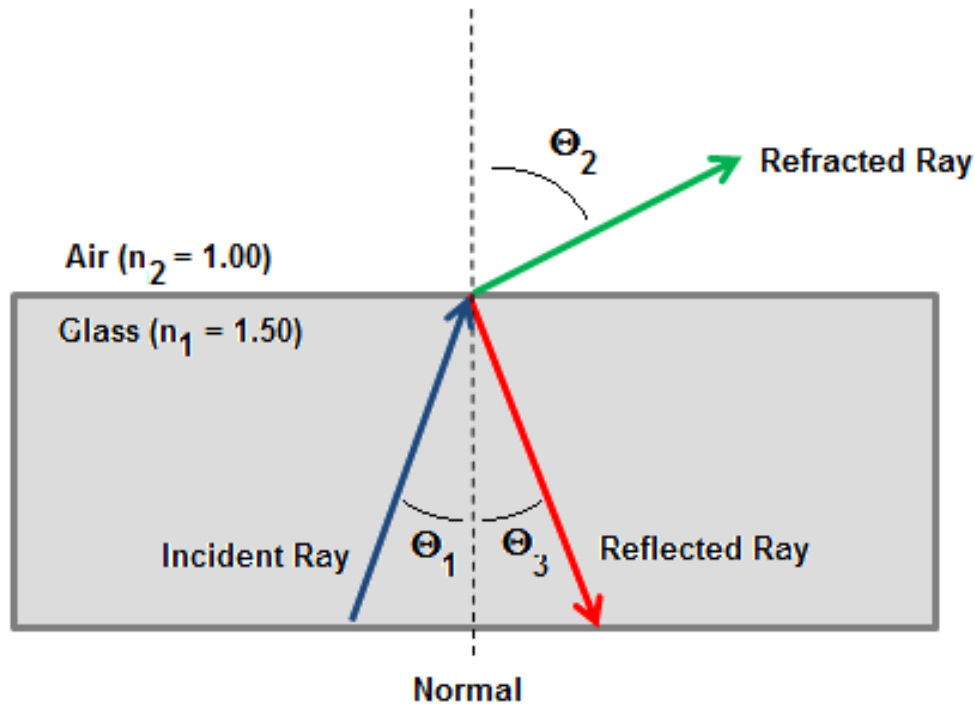

Let's assume the light ray or incident ray is traveling through the glass. When the light ray encounters the glass-air boundary, there are two results. The first result is that part of the ray is reflected back into the glass. The second result is that part of the ray is refracted (bent) as it enters the air. The bending of the light at the glass-air interface is the result of the difference between the index of refractions. Since  $n_1$  is greater than  $n_2$ , the angle of refraction ( $\Theta_2$ ) will be greater than the angle of incidence ( $\Theta_1$ ). Snell's law of refraction is used to describe the relationship between the incident and the refracted rays at the boundary. Snell's Law is given by,

$$n_1 * \sin(\Theta_1) = n_2 * \sin(\Theta_2)$$

Where,

$\Theta_1$  = Angle of incidence, degrees.

$\Theta_2$  = Angle of refraction, degrees.

$n_1$  = Index of refraction for material 1.

$n_2$  = Index of refraction for material 2.

As the angle of incidence ( $\Theta_1$ ) becomes larger, the angle of refraction ( $\Theta_2$ ) approaches 90 degrees. At this point, no refraction is possible. The light ray is totally reflected back into the glass medium. No light escapes into the air. This condition is called total *internal reflection*.

The angle at which total internal reflection occurs is called the *critical angle of incidence*. The critical angle of incidence ( $\Theta_c$ ) is shown in Figure 9. At any angle of incidence ( $\Theta_1$ ) greater than the critical angle, light is totally reflected back into the glass medium. The critical angle of incidence is determined by using Snell's Law. The critical angle is given by,

$$\sin(\Theta_c) = \frac{n_2}{n_1}$$

Where,

$\Theta_c$  = Critical angle of incidence, degrees.

$n_1$  = Index of refraction for material 1.

$n_2$  = Index of refraction for material 2.

Figure 9. - Critical angle of incidence.

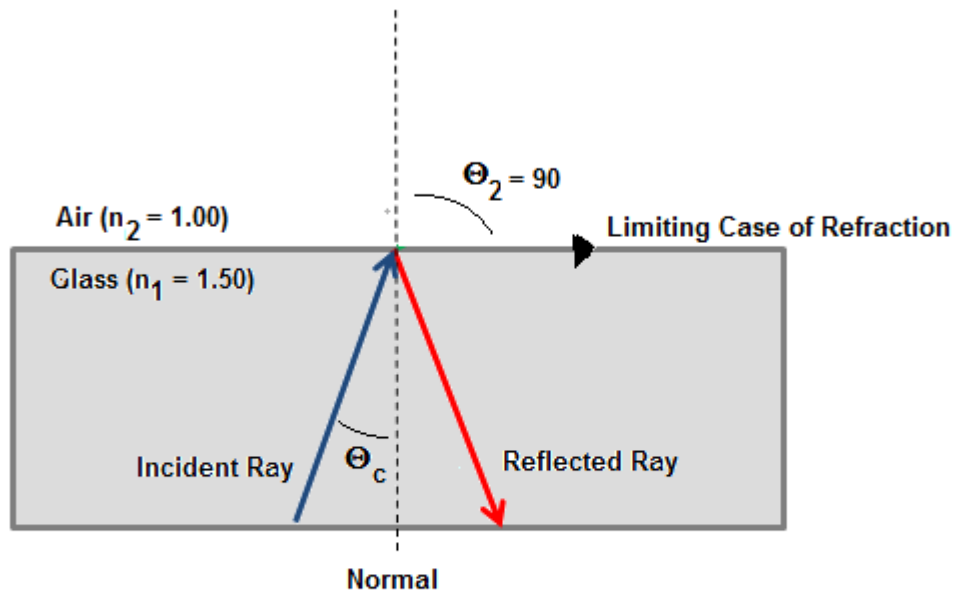

The condition of total internal reflection is an ideal situation.

However, in reality, there is always some light energy that penetrates the boundary. This situation is explained by the mode theory, or the electromagnetic wave theory, of light.

## Optical Fiber Structure

The basic structure of an optical fiber consists of three parts; the core, the cladding, and the coating or buffer. The basic structure of an optical fiber is shown in Figure 10. The *core* is a cylindrical rod of dielectric material. Dielectric material conducts no electricity. Light propagates mainly along the core of the fiber. The core is generally made of glass. The core is described as having a radius of  $(a)$  and an index of refraction  $n_1$ . The core is surrounded by a layer of material called the *cladding*. Even though light will propagate along the fiber core without the layer of cladding material, the cladding does perform some necessary functions.

Figure 10. - Basic structure of an optical fiber.

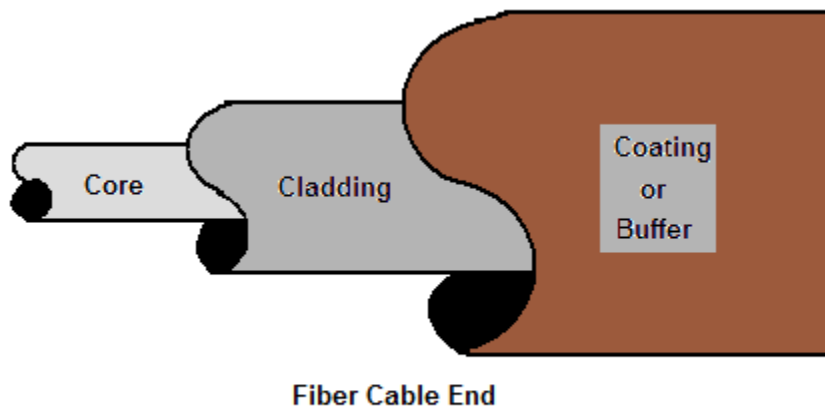

The cladding layer is made of a dielectric material with an index of refraction  $n_2$ . The index of refraction of the cladding material is less than that of the core material. The cladding is generally made of glass or plastic. The cladding performs the following functions:

- Reduces loss of light from the core into the surrounding air
- Reduces scattering loss at the surface of the core
- Protects the fiber from absorbing surface contaminants
- Adds mechanical strength

For extra protection, the cladding is enclosed in an additional layer called the coating or buffer. The coating or buffer is a layer of material used to protect an optical fiber from physical damage. The material used for a buffer is a type of plastic.

The buffer is elastic in nature and prevents abrasions. The buffer also prevents the optical fiber from scattering losses caused by microbends. Microbends occur when an optical fiber is placed on a rough and distorted surface.

## Propagation of Light along a Fiber

The concept of light propagation, the transmission of light along an optical fiber, can be described by two theories. According to the first theory, light is described as a simple ray. This theory is the ray theory, or geometrical optics, approach. The advantage of the ray approach is that you get a clearer picture of the propagation of light along a fiber. The ray theory is used to approximate the light acceptance and guiding properties of optical fibers. According to the second theory, light is described as an electromagnetic wave. This theory is the mode theory, or wave representation, approach. The mode theory describes the behavior of light within an optical fiber. The mode theory is useful in describing the optical fiber properties of absorption, attenuation, and dispersion.

### Ray Theory

Two types of rays can propagate along an optical fiber. The first type is called meridional rays. *Meridional rays* are rays that pass through the axis of the optical fiber. Meridional rays are used to illustrate the basic transmission properties of optical fibers.

The second type is called skew rays. *Skew rays* are rays that travel through an optical fiber without passing through its axis.

#### Meridional Rays

Meridional rays can be classified as bound or unbound rays. Bound rays remain in the core and propagate along the axis of the fiber. *Bound rays* propagate through the fiber by total internal reflection. *Unbound rays* are refracted out of the fiber core. Figure 11 shows a possible path taken by bound and unbound rays in a step-index fiber. The core of the step-index fiber has an index of refraction  $n_1$ . The cladding of a step-index has an index of refraction  $n_2$ , which is lower than  $n_1$ . Figure 11 assumes the core-cladding interface is perfect. However, imperfections at the core-cladding interface will cause part of the bound rays to be refracted out of the core into the cladding. The light rays refracted into the cladding will eventually escape from the fiber. In general, meridional rays follow the laws of reflection and refraction.

Figure 11. - Bound and unbound rays in a step-index fiber.

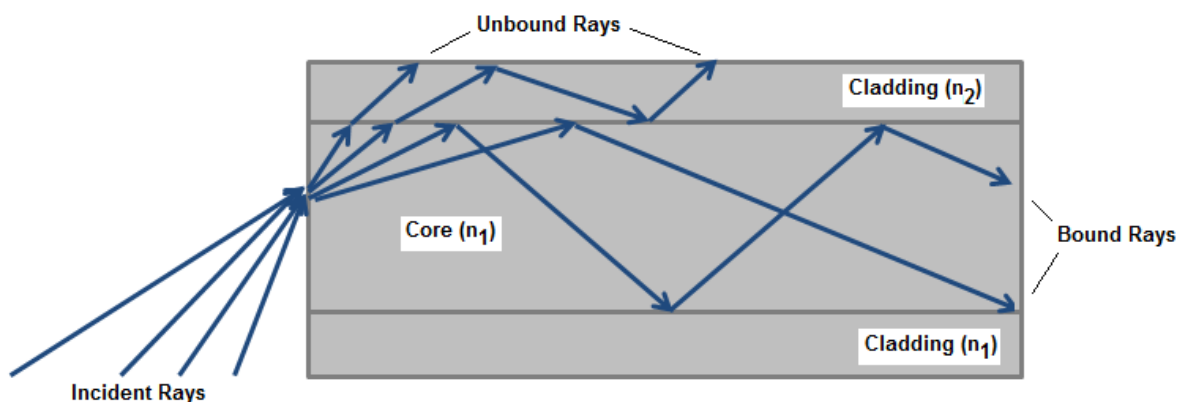

It is known that bound rays propagate in fibers due to total internal reflection, but how do these light rays enter the fiber? Rays that enter the fiber must intersect the core-cladding interface at an angle greater than the critical angle ( $\Theta_c$ ). Only those rays that enter the fiber and strike the interface at these angles will propagate along the fiber.

How a light ray is launched into a fiber is shown in Figure 12. The incident ray  $I_1$  enters the fiber at the angle  $\Theta_a$ .  $I_1$  is refracted upon entering the fiber and is transmitted to the core-cladding interface. The ray then strikes the core-cladding interface at the critical angle ( $\Theta_c$ ).  $I_1$  is totally reflected back into the core and continues to propagate along the fiber. The incident ray  $I_2$  enters the fiber at an angle greater than  $\Theta_a$ . Again,  $I_2$  is refracted upon entering the fiber and is transmitted to the core-cladding interface.  $I_2$  strikes the core-cladding interface at an angle less than the critical angle ( $\Theta_c$ ).  $I_2$  is refracted into the cladding and is eventually lost. The light ray incident on the fiber core must be within the *acceptance cone* defined by the angle  $\Theta_a$  shown in Figure 13.

Angle  $\Theta_a$  is defined as the acceptance angle. The *acceptance angle* ( $\Theta_a$ ) is the maximum angle to the axis of the fiber that light entering the fiber is propagated. The value of the angle of acceptance ( $\Theta_a$ ) depends on fiber properties and transmission conditions.

Figure 12. - How a light ray enters an optical fiber.

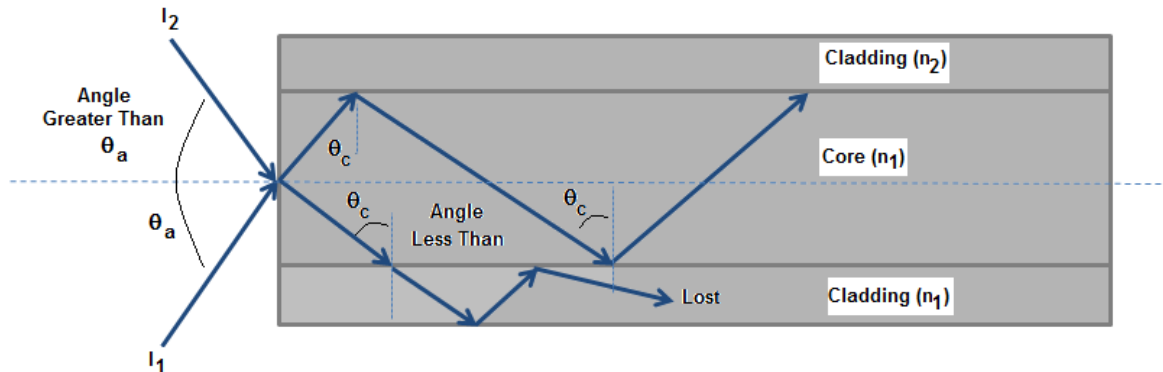
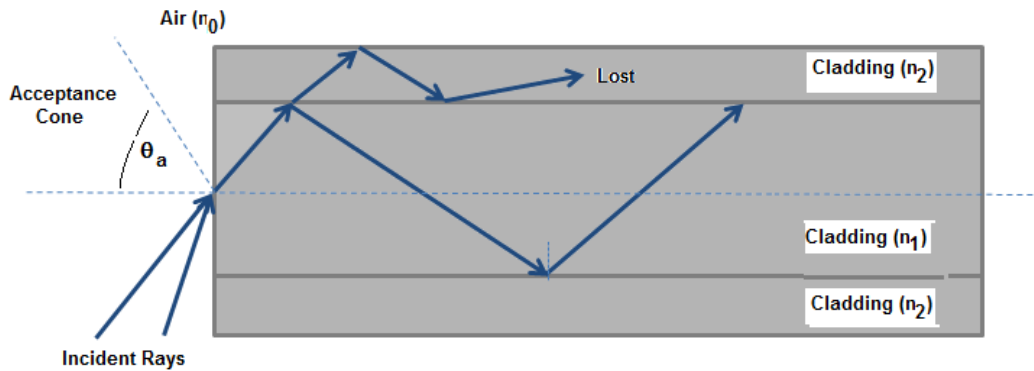

Figure 13. - Fiber acceptance angle.



The acceptance angle is related to the refractive indices of the core, cladding, and medium surrounding the fiber. This relationship is called the *numerical aperture* of the fiber. The numerical aperture (NA) is a measurement of the ability of an optical fiber to capture light. The NA is also used to define the acceptance cone of an optical fiber.

Figure 14 illustrates the relationship between the acceptance angle and the refractive indices. The index of refraction of the fiber core is  $n_1$ . The index of refraction of the fiber cladding is  $n_2$ . The index of refraction of the surrounding medium is  $n_0$ . By using Snell's law and basic trigonometric relationships, the NA of the fiber is given by,

$$NA = n_0 * \sin(\Theta_a) = \sqrt{n_2^2 - n_1^2}$$

Where,

NA = Numerical Aperture.

$\Theta_a$  = Angle of incidence, degrees.

$n_0$  = Index of refraction, surrounding medium (generally air).

$n_1$  = Index of refraction, fiber core.

$n_2$  = Index of refraction, fiber cladding.

Since the medium next to the fiber at the launching point is normally air,  $n_0$  is equal to 1.00. The NA is then simply equal to  $\sin(\Theta_a)$ .

The NA is a convenient way to measure the light-gathering ability of an optical fiber. It is used to measure source-to-fiber power-coupling efficiencies. A high NA indicates a high source-to-fiber coupling efficiency.

Typical values of NA range from 0.20 to 0.29 for glass fibers. Plastic fibers generally have a higher NA. An NA for plastic fibers can be higher than 0.50. In addition, the NA is commonly used to specify multimode fibers.

However, for small core diameters, such as in single mode fibers, the ray theory breaks down. Ray theory describes only the direction a plane wave takes in a fiber. Ray theory eliminates any properties of the plane wave that interfere with the transmission of light along a fiber. In reality, plane waves interfere with each other. Therefore, only certain types of rays are able to propagate in an optical fiber. Optical fibers can support only a specific number of guided modes. In small core fibers, the number of modes supported is one or only a few modes. Mode theory is used to describe the types of plane waves able to propagate along an optical fiber.

### Skew Rays

A possible path of propagation of skew rays is shown in Figure 14.

Figure 14, the first view provides an angled view and the second view provides a front view.

Skew rays propagate without passing through the center axis of the fiber.

The acceptance angle for skew rays is larger than the acceptance angle of meridional rays. This condition explains why skew rays outnumber meridional rays. Skew rays are often used in the calculation of light acceptance in an optical fiber. The addition of skew rays increases the amount of light capacity of a fiber. In large NA fibers, the increase may be significant.

Figure 14. - Skew ray propagation: Angled view; Front view.

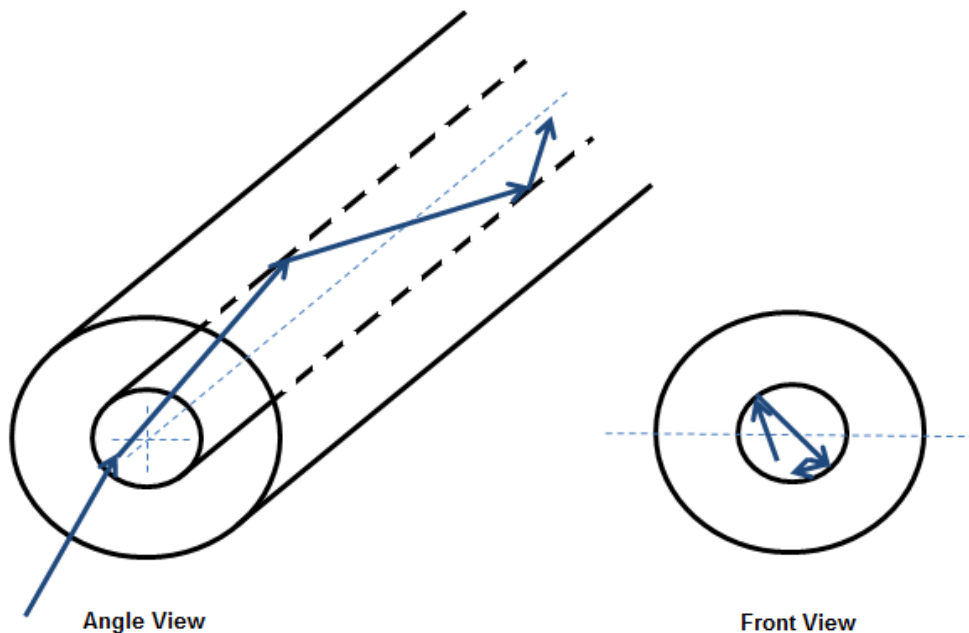



The addition of skew rays also increases the amount of loss in a fiber. Skew rays tend to propagate near the edge of the fiber core. A large portion of the number of skew rays that are trapped in the fiber core are considered to be leaky rays. Leaky rays are predicted to be totally reflected at the core-cladding boundary. However, these rays are partially refracted because of the curved nature of the fiber boundary. Mode theory is also used to describe this type of leaky ray loss.

## Mode Theory

The mode theory, along with the ray theory, is used to describe the propagation of light along an optical fiber. The mode theory is used to describe the properties of light that ray theory is unable to explain. The mode theory uses electromagnetic wave behavior to describe the propagation of light along a fiber. A set of guided electromagnetic waves is called the modes of the fiber.

### Plane Waves

The mode theory suggests that a light wave can be represented as a plane wave. A plane wave is described by its direction, amplitude, and wavelength of propagation. A *plane wave* is a wave whose surfaces of constant phase are infinite parallel planes normal to the direction of propagation.

The planes having the same phase are called the wavefronts. The wavelength ( $\lambda$ ) of the plane wave is given by,

$$\lambda = \frac{c}{f \cdot n}$$

Where,

$\lambda$  = Wavelength.

$c$  = Speed of light in a vacuum,  $3 \times 10^8$  meters per second (m/s).

$f$  = Frequency of light.

$n$  = Index of refraction of the medium.

Figure 15 shows the direction and wavefronts of plane-wave propagation. Plane waves, or wavefronts, propagate along the fiber similar to light rays. However, not all wavefronts incident on the fiber at angles less than or equal to the critical angle of light acceptance propagate along the fiber. Wavefronts may undergo a change in phase that prevents the successful transfer of light along the fiber.

Figure 15. - Plane-wave propagation.

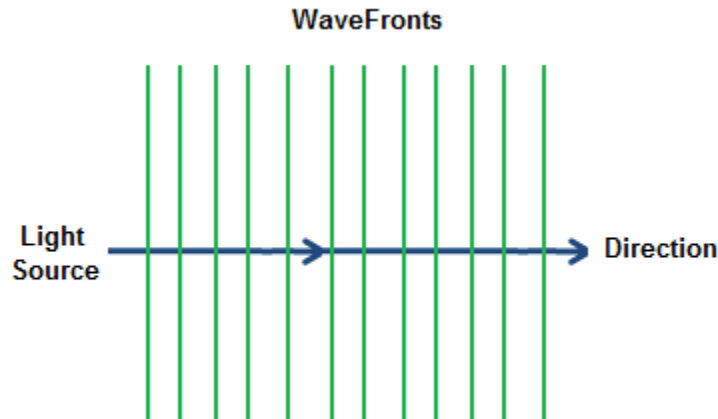

Wavefronts are required to remain in phase for light to be transmitted along the fiber. Consider the wavefront incident on the core of an optical fiber as shown in Figure 16. Only those wavefronts incident on the fiber at angles less than or equal to the critical angle may propagate along the fiber. The wavefront undergoes a gradual phase change as it travels down the fiber. Phase changes also occur when the wavefront is reflected. The wavefront must remain in phase after the wavefront transverses the fiber twice and is reflected twice. The distance transversed is shown between point A and point B on Figure 16. The reflected waves at point A and point B are in phase if the total amount of phase collected is an integer multiple of  $2\pi$  radian. If propagating wavefronts are not in phase, they eventually disappear. Wavefronts disappear because of *destructive interference*. The wavefronts that are in phase interfere with the wavefronts that are out of phase. This interference is the reason why only a finite number of modes can propagate along the fiber.

Figure 16. - Wavefront propagation along an optical fiber.

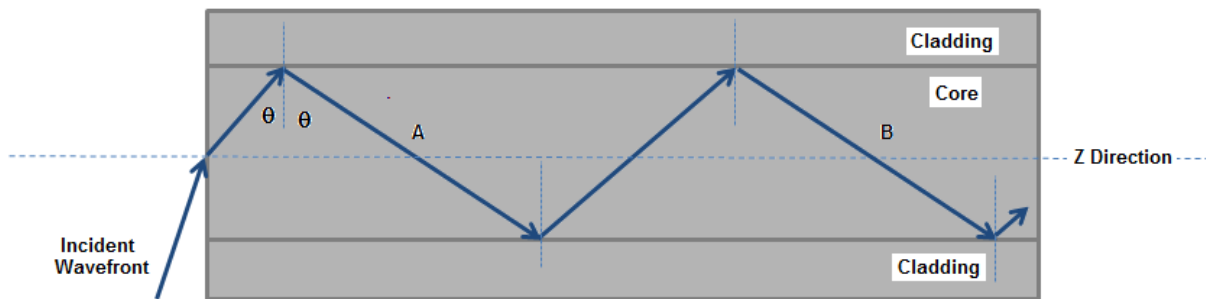

The plane waves repeat as they travel along the fiber axis. The direction the plane wave travels is assumed to be the z-direction as shown in Figure 16. The plane waves repeat at a distance equal to  $\lambda/\sin(\Theta)$ . Plane waves also repeat at a periodic frequency  $\beta = 2\pi \sin(\Theta)/\lambda$ . The quantity

$\beta$  is defined as the *propagation constant* along the fiber axis. As the wavelength ( $\lambda$ ) changes, the value of the propagation constant must also change.

For a given mode, a change in wavelength can prevent the mode from propagating along the fiber. The mode is no longer bound to the fiber. The mode is said to be cut off. Modes that are bound at one wavelength may not exist at longer wavelengths. The wavelength at which a mode ceases to be bound is called the *cutoff wavelength* for that mode. However, an optical fiber is always able to propagate at least one mode. This mode is referred to as the fundamental mode of the fiber. The fundamental mode can never be cut off.

The wavelength that prevents the next higher mode from propagating is called the cutoff wavelength of the fiber. An optical fiber that operates above the cutoff wavelength (at a longer wavelength) is called a single mode fiber. An optical fiber that operates below the cutoff wavelength is called a multimode fiber.

In a fiber, the propagation constant of a plane wave is a function of the wave's wavelength and mode. The change in the propagation constant for different waves is called *dispersion*. The change in the propagation constant for different wavelengths is called *chromatic dispersion*. The change in propagation constant for different modes is called *modal dispersion*.

These dispersions cause the light pulse to spread as it goes down the fiber (See Figure 17). Some dispersion occurs in all types of fibers.

Figure 17. - The spreading of a light pulse.

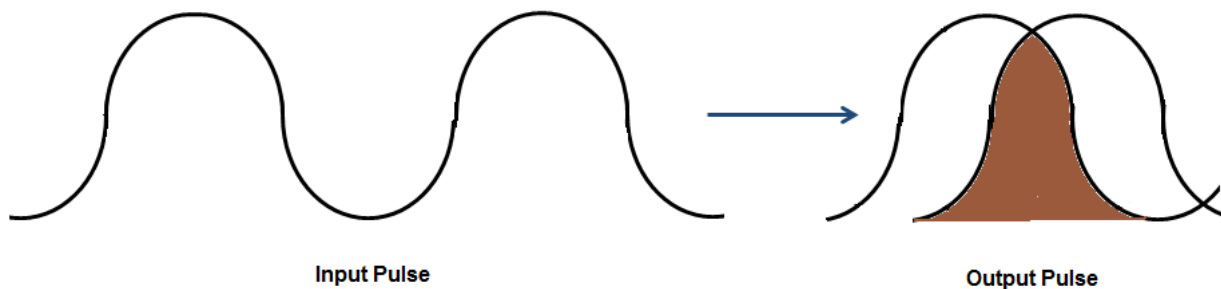

Modes - A set of guided electromagnetic waves is called the modes of an optical fiber.

Maxwell's equations describe electromagnetic waves or modes as having two components. The two components are the electric field,  $E(x, y, z)$ , and the magnetic field,  $H(x, y, z)$ . The electric field,  $E$ , and the magnetic field,  $H$ , are at right angles to each other. Modes traveling in an optical fiber are said to be transverse. The transverse modes, shown in Figure 18, propagate along the axis of the fiber. The mode field patterns shown in Figure 18 are said to be transverse electric (TE). In TE modes, the electric field is perpendicular to the direction of propagation.

The magnetic field is in the direction of propagation. Another type of transverse mode is the transverse magnetic (TM) mode. TM modes are opposite to TE modes. In TM modes, the

magnetic field is perpendicular to the direction of propagation. The electric field is in the direction of propagation. Figure 18 shows only TE modes.

Figure 18. - Transverse electric (TE) mode field patterns.

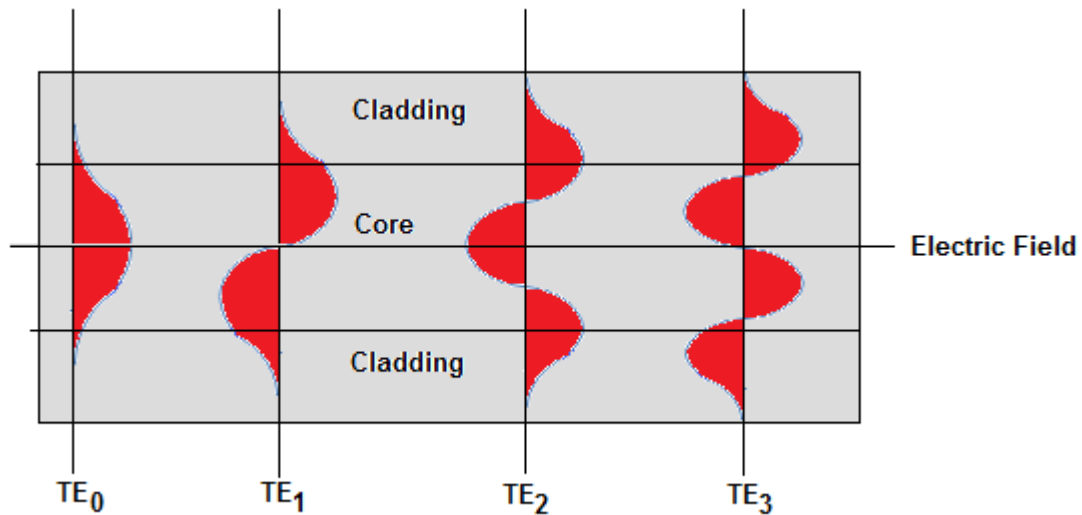

The TE mode field patterns shown in Figure 18 indicate the order of each mode. The order of each mode is indicated by the number of field maxima within the core of the fiber. For example, TE<sub>0</sub> has one field maxima. The electric field is a maximum at the center of the waveguide and decays toward the core-cladding boundary. TE<sub>0</sub> is considered the fundamental mode or the lowest order standing wave. As the number of field maxima increases, the order of the mode is higher. Generally, modes with more than a few (5-10) field maxima are referred to as high-order modes.

The order of the mode is also determined by the angle the wavefront makes with the axis of the fiber. Figure 19 illustrates light rays as they travel down the fiber. These light rays indicate the direction of the wavefronts. High-order modes cross the axis of the fiber at steeper angles. Low-order and high-order modes are shown in Figure 19.

Figure 19. - Low-order and high-order modes.

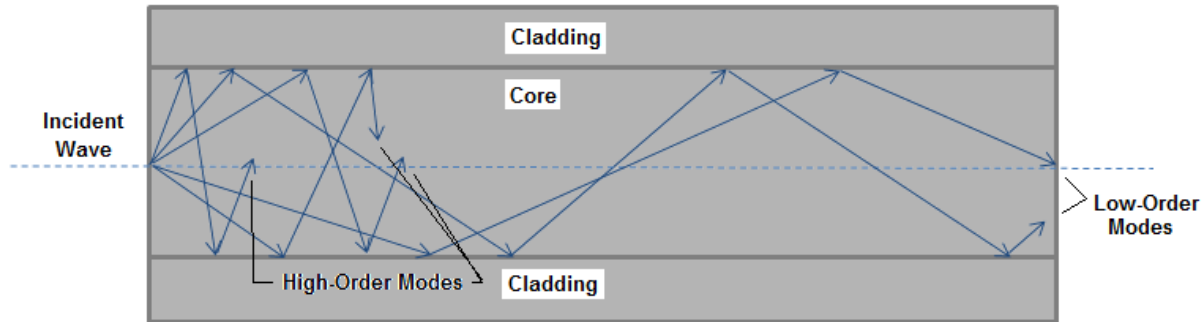

Before we progress, let us refer back to Figure 18.

Notice that the modes are not confined to the core of the fiber. The modes extend partially into the cladding material. Low-order modes penetrate the cladding only slightly. In low-order modes, the electric and magnetic fields are concentrated near the center of the fiber. However, high-order modes penetrate further into the cladding material. In high-order modes, the electrical and magnetic fields are distributed more toward the outer edges of the fiber.

This penetration of low-order and high-order modes into the cladding region indicates that some portion is refracted out of the core. The refracted modes may become trapped in the cladding due to the dimension of the cladding region. The modes trapped in the cladding region are called *cladding modes*. As the core and the cladding modes travel along the fiber, mode coupling occurs. *Mode coupling* is the exchange of power between two modes. Mode coupling to the cladding results in the loss of power from the core modes.

In addition to bound and refracted modes, there are leaky modes.

Leaky modes are similar to leaky rays. *Leaky modes* lose power as they propagate along the fiber. For a mode to remain within the core, the mode must meet certain boundary conditions. A mode remains bound if the propagation constant beta ( $\beta$ ) meets the following boundary condition,

$$\frac{2 * \pi * n_2}{\lambda} < \beta < \frac{2 * \pi * n_1}{\lambda}$$

Where,

$\lambda$  = Wavelength.

$\beta$  = Propagation constant.

$n_1$  = Index of refraction for the core.

$n_2$  = Index of refraction for the cladding.

When the propagation constant becomes smaller than  $2\pi n_2/\lambda$ , power leaks out of the core and into the cladding. Generally, modes leaked into the cladding are lost in a few centimeters. However, leaky modes can carry a large amount of power in short fibers.

### Normalized Frequency

Electromagnetic waves bound to an optical fiber are described by the fiber's normalized frequency.

The *normalized frequency* determines how many modes a fiber can support. Normalized frequency is a dimensionless quantity.

Normalized frequency is also related to the fiber's cutoff wavelength. Normalized frequency ( $V$ ) is defined as,

$$V = \frac{2*\pi*a}{l} * \sqrt{n_2^2 - n_1^2}$$

Where,

$V$  = Normalized Frequency.

$a$  = Core diameter.

$\lambda$  = Wavelength of light in air.

$n_1$  = Core index of refraction.

$n_2$  = Cladding index of refraction.

$l$  = Wavelength of light in air.

The number of modes that can exist in a fiber is a function of  $V$ . As the value of  $V$  increases, the number of modes supported by the fiber increases. Optical fibers, single mode and multimode, can support a different number of modes.

## Chapter 3

### Optical Fiber Types

Optical fibers are characterized by their structure and by their properties of transmission. Basically, optical fibers are classified into two types. The first type is single mode fibers. The second type is multimode fibers. As each name implies, optical fibers are classified by the number of modes that propagate along the fiber. As previously explained, the structure of the fiber can permit or restrict modes from propagating in a fiber. The basic structural difference is the core size. Single mode fibers are manufactured with the same materials as multimode fibers. Single mode fibers are also manufactured by following the same fabrication process as multimode fibers.

#### Single Mode Fibers

The core size of single mode fibers is small. The core size (diameter) is typically around 8 to 10 micrometers ( $\mu\text{m}$ ). A fiber core of this size allows only the fundamental or lowest order mode to propagate around a 1300 nanometer (nm) wavelength. Single mode fibers propagate only one mode, because the core size approaches the operational wavelength ( $\lambda$ ). The value of the normalized frequency parameter ( $V$ ) relates core size with mode propagation.

In single mode fibers,  $V$  is less than or equal to 2.405. When  $V$  is less than or equal to 2.405, single mode fibers propagate the fundamental mode down the fiber core, while high-order modes are lost in the cladding. For low  $V$  values ( $\leq 1.0$ ), most of the power is propagated in the cladding material. Power transmitted by the cladding is easily lost at fiber bends. The value of  $V$  should remain near the 2.405 level.

Single mode fibers have a lower signal loss and a higher information capacity (bandwidth) than multimode fibers. Single mode fibers are capable of transferring higher amounts of data due to low fiber dispersion. Basically, dispersion is the spreading of light as light propagates along a fiber. Dispersion mechanisms in single mode fibers are discussed in more detail later in this chapter. Signal loss depends on the operational wavelength ( $\lambda$ ). In single mode fibers, the wavelength can increase or decrease the losses caused by fiber bending. Single mode fibers operating at wavelengths larger than the cutoff wavelength lose more power at fiber bends. They lose power because light radiates into the cladding, which is lost at fiber bends. In general, single mode fibers are considered to be low-loss fibers, which increase system bandwidth and length.

#### Multimode Fibers

As their name implies, multimode fibers propagate more than one mode. Multimode fibers can propagate over 100 modes. The number of modes propagated depends on the core size and numerical aperture (NA). As the core size and

NA increase, the number of modes increases. Typical values of fiber core size and NA are 50 to 100  $\mu\text{m}$  and 0.20 to 0.29, respectively.

A large core size and a higher NA have several advantages. Light is launched into a multimode fiber with more ease. The higher NA and the larger core size make it easier to make fiber connections. During fiber splicing, core-to-core alignment becomes less critical. Another advantage is that multimode fibers permit the use of light-emitting diodes (LEDs). Single mode fibers typically must use laser diodes. LEDs are cheaper, less complex, and last longer. LEDs are preferred for most applications.

Multimode fibers also have some disadvantages. As the number of modes increases, the effect of modal dispersion increases. Modal dispersion (intermodal dispersion) means that modes arrive at the fiber end at slightly different times. This time difference causes the light pulse to spread. Modal dispersion affects system bandwidth. Fiber manufacturers adjust the core diameter, NA, and index profile properties of multimode fibers to maximize system bandwidth.

### **Properties of Optical Fiber Transmission**

The principles behind the transfer of light along an optical fiber were discussed earlier in this chapter. We learned that propagation of light depended on the nature of light and the structure of the optical fiber. However, our discussion did not describe how optical fibers affect system performance.

In this case, system performance deals with signal loss and bandwidth.

Signal loss and system bandwidth describe the amount of data transmitted over a specified length of fiber. Many optical fiber properties increase signal loss and reduce system bandwidth. The most important properties that affect system performance are fiber attenuation and dispersion.

Attenuation reduces the amount of optical power transmitted by the fiber. Attenuation controls the distance an optical signal (pulse) can travel as shown in Figure 20. Once the power of an optical pulse is reduced to a point where the receiver is unable to detect the pulse, an error occurs. Attenuation is mainly a result of light absorption, scattering, and bending losses. Dispersion spreads the optical pulse as it travels along the fiber. This spreading of the signal pulse reduces the system bandwidth or the information-carrying capacity of the fiber. Dispersion limits how fast information is transferred as shown in Figure 20. An error occurs when the receiver is unable to distinguish between input pulses caused by the spreading of each pulse. The effects of attenuation and dispersion increase as the pulse travels the length of the fiber as shown in Figure 21.



Figure 20. - Fiber transmission properties.

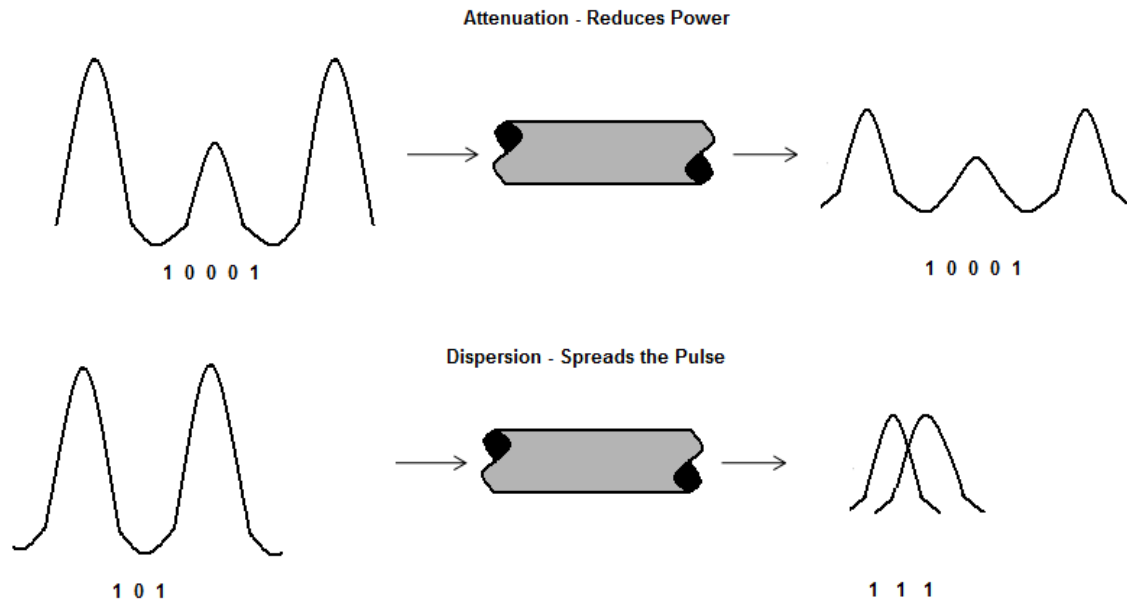
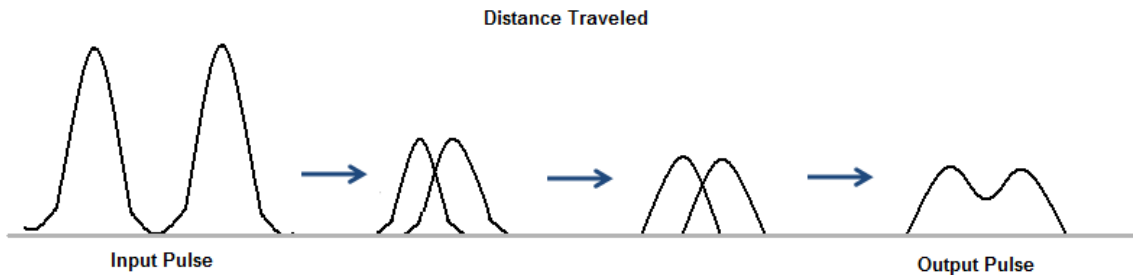

Figure 21. - Pulse spreading and power loss along an optical fiber.



In addition to fiber attenuation and dispersion, other optical fiber properties affect system performance. Fiber properties, such as modal noise, pulse broadening, and polarization, can reduce system performance.

Modal noise, pulse broadening, and polarization are too complex to discuss as introductory level material. However, be aware that attenuation and dispersion are not the only fiber properties that affect performance.

### Attenuation

Attenuation in an optical fiber is caused by absorption, scattering, and bending losses. *Attenuation* is the loss of optical power as light travels along the fiber. Signal attenuation is defined as the ratio of optical input power ( $P_i$ ) to the optical output power ( $P_o$ ). Optical input

power is the power injected into the fiber from an optical source. Optical output power is the power received at the fiber end or optical detector. The following equation defines signal attenuation as a unit of length,

$$\text{Attenuation} = \frac{10}{L} * \log 10 \left( \frac{P_i}{P_0} \right)$$

Where,

L = Length of the cable, kilometers.

P<sub>i</sub> = Power input, watts.

P<sub>0</sub> = Power output, watts.

Signal attenuation is a log relationship. Length (L) is expressed in kilometers. Therefore, the unit of attenuation is decibels/kilometer (dB/km). As previously stated, attenuation is caused by absorption, scattering, and bending losses. Each mechanism of loss is influenced by fiber-material properties and fiber structure. However, loss is also present at fiber connections. The present discussion remains relative to optical fiber attenuation properties.

### Absorption

Absorption is a major cause of signal loss in an optical fiber. *Absorption* is defined as the portion of attenuation resulting from the conversion of optical power into another energy form, such as heat. Absorption in optical fibers is explained by three factors:

- Imperfections in the atomic structure of the fiber material
- The intrinsic or basic fiber-material properties
- The extrinsic (presence of impurities) fiber-material properties

Imperfections in the atomic structure induce absorption by the presence of missing molecules or oxygen defects. Absorption is also induced by the diffusion of hydrogen molecules into the glass fiber. Since intrinsic and extrinsic material properties are the main cause of absorption, they are discussed further.

**Intrinsic Absorption.** - *Intrinsic absorption* is caused by basic fiber-material properties. If an optical fiber were absolutely pure, with no imperfections or impurities, then all absorption would be intrinsic. Intrinsic absorption sets the minimal level of absorption.

In fiber optics, silica (pure glass) fibers are used predominately. Silica fibers are used because of their low intrinsic material absorption at the wavelengths of operation.

In silica glass, the wavelengths of operation range from 700 nanometers (nm) to 1600 nm. Figure 22 shows the level of attenuation at the wavelengths of operation. This wavelength of operation is between two intrinsic absorption regions. The first region is the ultraviolet region (below 400-nm wavelength). The second region is the infrared region (above 2000-nm wavelength).

Figure 22. - Fiber losses.

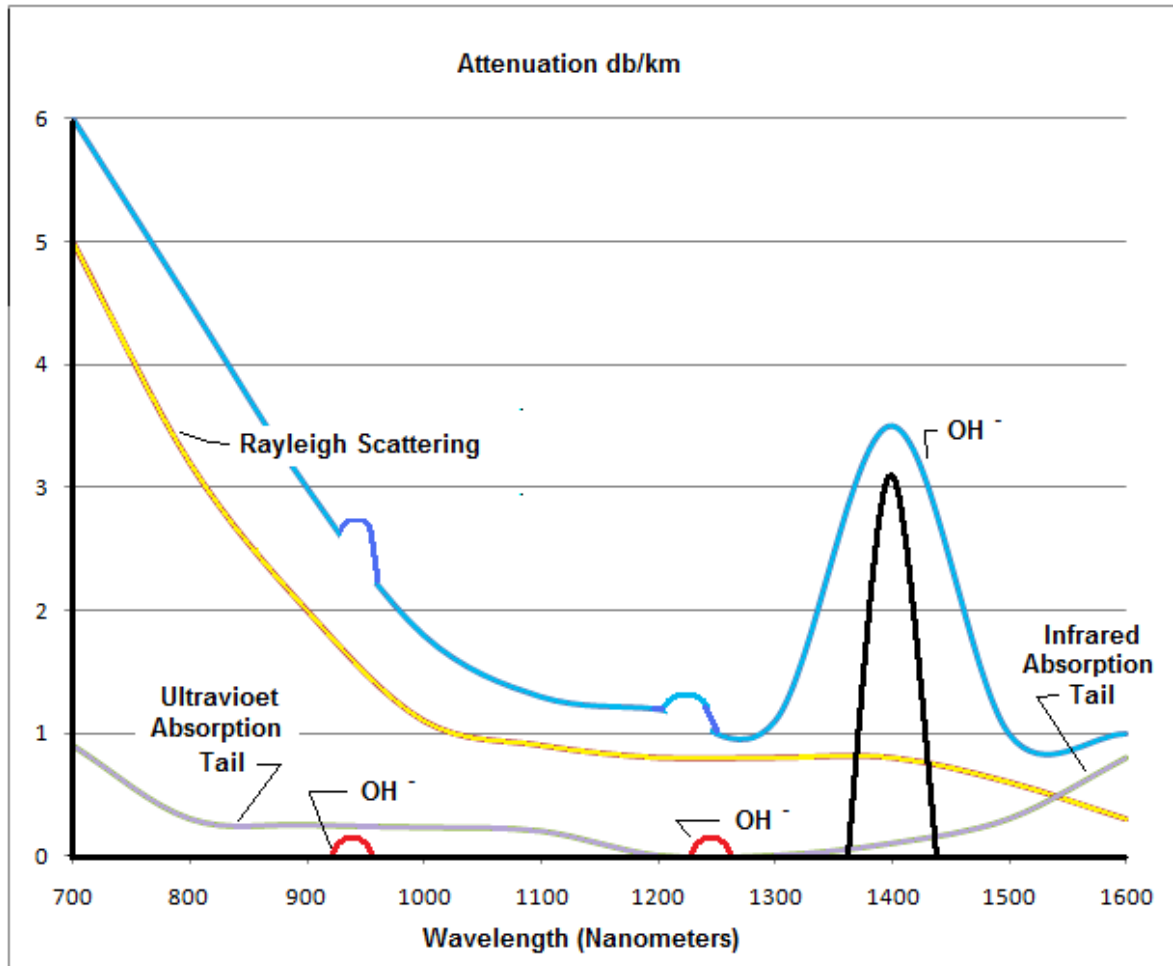

Intrinsic absorption in the ultraviolet region is caused by electronic absorption bands. Basically, absorption occurs when a light particle (photon) interacts with an electron and excites it to a higher energy level. The tail of the ultraviolet absorption band is shown in Figure 22.

The main cause of intrinsic absorption in the infrared region is the characteristic vibration frequency of atomic bonds. In silica glass, absorption is caused by the vibration of silicon-oxygen (Si-O) bonds. The interaction between the vibrating bond and the electromagnetic field of the optical signal causes intrinsic absorption. Light energy is transferred from the electromagnetic field to the bond. The tail of the infrared absorption band is shown in Figure 22.

Extrinsic Absorption. - *Extrinsic absorption* is caused by impurities introduced into the fiber material. Trace metal impurities, such as iron, nickel, and chromium, are introduced into the fiber during fabrication. Extrinsic absorption is caused by the electronic transition of these metal ions from one energy level to another.

Extrinsic absorption also occurs when hydroxyl ions ( $\text{OH}^-$ ) are introduced into the fiber. Water in silica glass forms a silicon-hydroxyl ( $\text{Si-OH}$ ) bond. This bond has a fundamental absorption at 2700 nm. However, the harmonics or overtones of the fundamental absorption occur in the region of operation. These harmonics increase extrinsic absorption at 1383 nm, 1250 nm, and 950 nm. Figure 22 shows the presence of the three  $\text{OH}^-$  harmonics. The level of the  $\text{OH}^-$  harmonic absorption is also indicated.

These absorption peaks define three regions or windows of preferred operation. The first window is centered at 850 nm. The second window is centered at 1300 nm. The third window is centered at 1550 nm. Fiber optic systems operate at wavelengths defined by one of these windows.

The amount of water ( $\text{OH}^-$ ) impurities present in a fiber should be less than a few parts per billion. Fiber attenuation caused by extrinsic absorption is affected by the level of impurities ( $\text{OH}^-$ ) present in the fiber. If the amount of impurities in a fiber is reduced, then fiber attenuation is reduced.

### Scattering

Basically, *scattering losses* are caused by the interaction of light with density fluctuations within a fiber. Density changes are produced when optical fibers are manufactured.

During manufacturing, regions of higher and lower molecular density areas, relative to the average density of the fiber, are created. Light traveling through the fiber interacts with the density areas as shown in Figure 23. Light is then partially scattered in all directions.

Figure 23. - Light scattering.

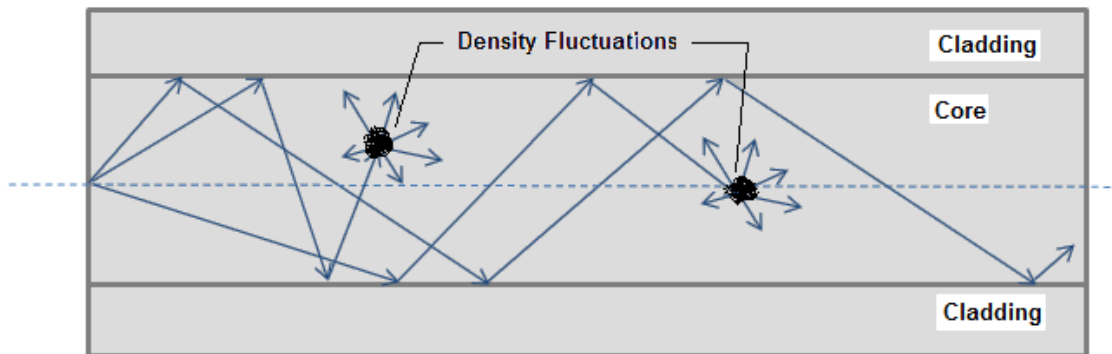

In commercial fibers operating between 700-nm and 1600-nm wavelength, the main source of loss is called *Rayleigh scattering*. Rayleigh scattering is the main loss mechanism between the ultraviolet and infrared regions as shown in Figure 22. Rayleigh scattering occurs when the size of the density fluctuation (fiber defect) is less than one-tenth of the operating wavelength of light. Loss caused by Rayleigh scattering is proportional to the fourth power of the wavelength ( $1/\lambda^4$ ). As the wavelength increases, the loss caused by Rayleigh scattering decreases.

If the size of the defect is greater than one-tenth of the wavelength of light, the scattering mechanism is called *Mie scattering*. Mie scattering, caused by these large defects in the fiber core, scatters light out of the fiber core. However, in commercial fibers, the effects of Mie scattering are insignificant. Optical fibers are manufactured with very few large defects.

### Bending Loss

Bending the fiber also causes attenuation. *Bending loss* is classified according to the bend radius of curvature: microbend loss or macrobend loss.

*Microbends* are small microscopic bends of the fiber axis that occur mainly when a fiber is cabled. Macrobends are bends having a large radius of curvature relative to the fiber diameter. Microbend and macrobend losses are very important loss mechanisms. Fiber loss caused by microbending can still occur even if the fiber is cabled correctly. During installation, if fibers are bent too sharply, macrobend losses will occur.

*Microbend losses* are caused by small discontinuities or imperfections in the fiber. Uneven coating applications and improper cabling procedures increase microbend loss. External forces are also a source of microbends. An external force deforms the cabled jacket surrounding the fiber but causes only a small bend in the fiber. Microbends change the path that propagating modes take, as shown in Figure 24. Microbend loss increases attenuation because low-order modes become coupled with high-order modes that are naturally lossy.

Figure 24. - Microbend loss.

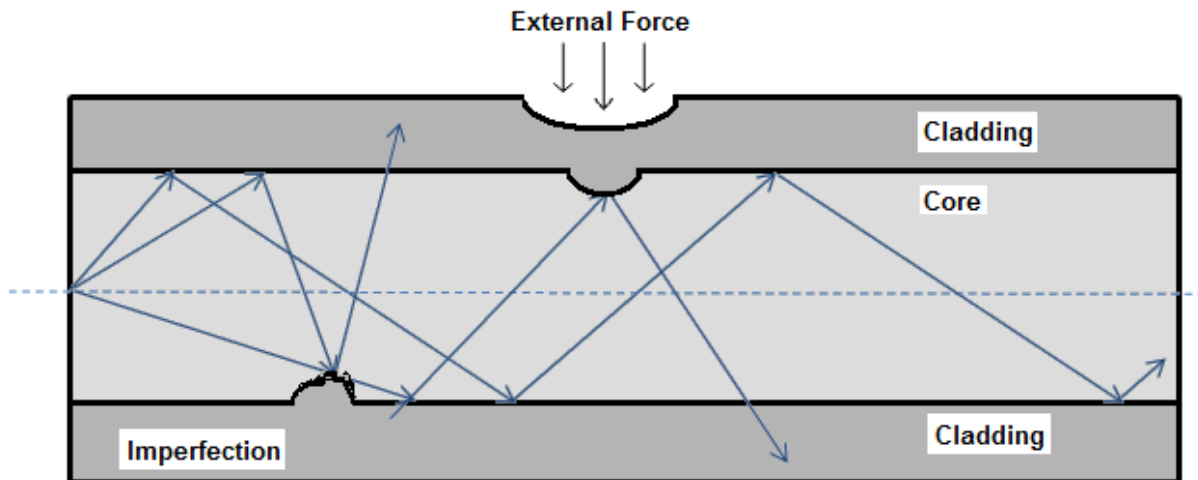

Macrobend losses are observed when a fiber bend's radius of curvature is large compared to the fiber diameter.

These bends become a great source of loss when the radius of curvature is less than several centimeters. Light propagating at the inner side of the bend travels a shorter distance than that on the outer side. To maintain the phase of the light wave, the mode phase velocity must increase.

When the fiber bend is less than some critical radius, the mode phase velocity must increase to a speed greater than the speed of light. However, it is impossible to exceed the speed of light. This condition causes some of the light within the fiber to be converted to high-order modes. These high-order modes are then lost or radiated out of the fiber.

Fiber sensitivity to bending losses can be reduced. If the refractive index of the core is increased, then fiber sensitivity decreases. Sensitivity also decreases as the diameter of the overall fiber increases. However, increases in the fiber core diameter increase fiber sensitivity. Fibers with larger core size propagate more modes. These additional modes tend to be more lossy.

## Dispersion

There are two different types of dispersion in optical fibers.

The types are intramodal and intermodal dispersion. Intramodal, or chromatic, dispersion occurs in all types of fibers. Intermodal, or modal, dispersion occurs only in multimode fibers. Each type of dispersion mechanism leads to pulse spreading. As a pulse spreads, energy is overlapped. This condition is shown in Figure 25. The spreading of the optical pulse as it travels along the fiber limits the information capacity of the fiber.

Figure 25. - Pulse overlap.

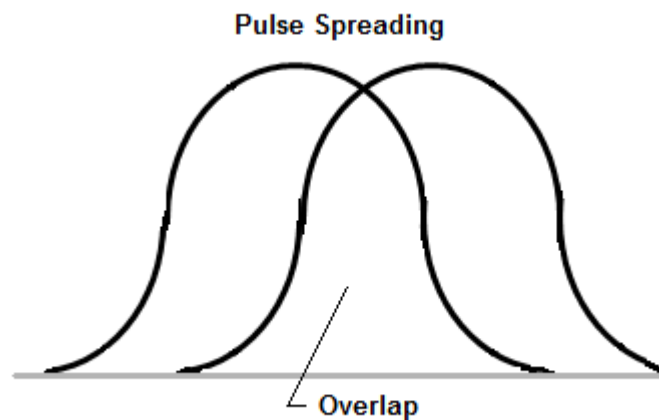

### Intramodal Dispersion

Intramodal, or chromatic, dispersion depends primarily on fiber materials. There are two types of intramodal dispersion. The first type is material dispersion. The second type is waveguide dispersion.

*Intramodal dispersion* occurs because different colors of light travel through different materials and different waveguide structures at different speeds.

*Material dispersion* occurs because the spreading of a light pulse is dependent on the wavelengths' interaction with the refractive index of the fiber core. Different wavelengths travel

at different speeds in the fiber material. Different wavelengths of a light pulse that enter a fiber at one time exit the fiber at different times. Material dispersion is a function of the source spectral width. The spectral width specifies the range of wavelengths that can propagate in the fiber. Material dispersion is less at longer wavelengths.

*Waveguide dispersion* occurs because the mode propagation constant ( $\beta$ ) is a function of the size of the fiber's core relative to the wavelength of operation. Waveguide dispersion also occurs because light propagates differently in the core than in the cladding.

In multimode fibers, waveguide dispersion and material dispersion are basically separate properties. Multimode waveguide dispersion is generally small compared to material dispersion. Waveguide dispersion is usually neglected.

However, in single mode fibers, material and waveguide dispersion are interrelated.

The total dispersion present in single mode fibers may be minimized by trading material and waveguide properties depending on the wavelength of operation.

### Intermodal Dispersion

Intermodal or modal dispersion causes the input light pulse to spread. The input light pulse is made up of a group of modes. As the modes propagate along the fiber, light energy distributed among the modes is delayed by different amounts. The pulse spreads because each mode propagates along the fiber at different speeds. Since modes travel in different directions, some modes travel longer distances. *Modal dispersion* occurs because each mode travels a different distance over the same time span, as shown in Figure 26. The modes of a light pulse that enter the fiber at one time exit the fiber at different times. This condition causes the light pulse to spread. As the length of the fiber increases, modal dispersion increases.

Figure 26. - Distance traveled by each mode over the same time span.

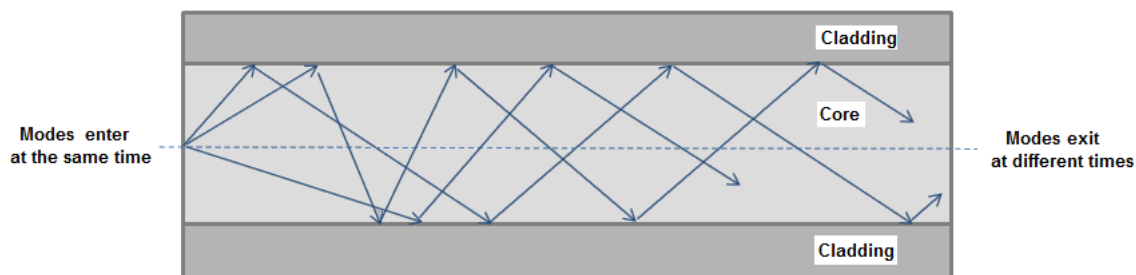

Modal dispersion is the dominant source of dispersion in multimode fibers. Modal dispersion does not exist in single mode fibers. Single mode fibers propagate only the fundamental mode. Therefore, single mode fibers exhibit the lowest amount of total dispersion. Single mode fibers also exhibit the highest possible bandwidth.

## Summary

The following is a summary of a few of the key concepts and terms that have been discussed in Volume I.

*Fiber optics* is the branch of optical technology concerned with the transmission of radiant power (light energy) through fibers.

A *fiber optic data link* has three basic functions: to convert an electrical input signal to an optical signal, to send the optical signal over an optical fiber, and to convert the optical signal back to an electrical signal. It consists of three parts: transmitter, optical fiber, and receiver.

The *transmitter* consists of two parts, an interface circuit and a source drive circuit. The transmitter converts the electrical input signal to an optical signal by varying the current flow through the light source.

The *receiver* consists of two parts, the optical detector and signal conditioning circuits. The receiver converts the optical signal exiting the fiber back into the original form of the electrical input signal.

*Scattering, absorption, and dispersion* mechanisms in the fiber waveguides cause the optical signal launched into the fiber to become weakened and distorted.

*Noise* is any disturbance that obscures or reduces the quality of the signal.

*Signal loss* is the decrease in the amount of light reaching the end of the fiber. Impurities in the fiber material cause the signal loss in optical fibers. By removing these impurities, construction of low-loss optical fibers was possible.

The two basic types of optical fibers are *multimode fibers* and *single mode fibers*.

*Fiber optic system design* has centered on long-haul communications and the subscriber-loop plant. Limited work has also been done on short-distance applications.

*Fiber performance* depends on the amount of loss and signal distortion introduced by the fiber when it is operating at a specific wavelength. Single mode fibers tend to have lower loss and produce less distortion than multimode fibers.

A *light wave* is a form of energy that is moved by wave motion.

*Wave motion* is defined as a recurring disturbance advancing through space with or without the use of a physical medium.

*Transverse wave motion* describes the up and down wave motion that is at right angle (transverse) to the outward motion of the waves.



*Light rays*, when they encounter any substance, are transmitted, refracted, reflected, or absorbed.

*Reflection* occurs when a wave strikes an object and bounces back (toward the source). The wave that moves from the source to the object is called the incident wave, and the wave that moves away from the object is called the reflected wave.

The *law of reflection* states that the angle of incidence is equal to the angle of reflection. Refraction occurs when a wave traveling through two different mediums passes through the boundary of the mediums and bends toward or away from the normal.

The *ray theory* and the *mode theory* describe how light energy is transmitted along an optical fiber.

The *index of refraction* is the basic optical material property that measures the speed of light in an optical medium.

*Snell's law of refraction* describes the relationship between the incident and the refracted rays when light rays encounter the boundary between two different transparent materials.

*Total internal reflection* occurs when light rays are totally reflected at the boundary between two different transparent materials. The angle at which total internal reflection occurs is called the critical angle of incidence.

The *core, cladding, and coating or buffer* are the three basic parts of an optical fiber. The *ray theory* describes how light rays propagate along an optical fiber. *Meridional rays* pass through the axis of the optical fiber. *Skew rays* propagate through an optical fiber without passing through its axis.

*Bound rays* propagate through an optical fiber core by total internal reflection. *Unbound rays* refract out of the fiber core into the cladding and are eventually lost.

The *acceptance angle* is the maximum angle to the axis of the fiber that light entering the fiber is bound or propagated.

*Numerical aperture (NA)* is a measurement of the ability of an optical fiber to capture light.

The *mode theory* uses electromagnetic wave behavior to describe the propagation of light along an optical fiber. A set of guided electromagnetic waves are called the modes of the fiber.

*Modes* traveling in an optical fiber are said to be transverse. Modes are described by their electric,  $e(x,y,z)$ , and magnetic,  $h(x,y,z)$ , fields. The electric field and magnetic field are at right angles to each other.

*Normalized frequency* determines how many modes a fiber can support. The number of modes is represented by the normalized frequency constant.

*Single mode* and *multimode fibers* are classified by the number of modes that propagate along the optical fiber. Single mode fibers propagate only one mode because the core size approaches the operational wavelength. Multimode fibers can propagate over 100 modes depending on the core size and numerical aperture.

*Attenuation* is the loss of optical power as light travels along an optical fiber. Attenuation in an optical fiber is caused by absorption, scattering, and bending losses.

*Dispersion* spreads the optical pulse as it travels along the fiber. Dispersion limits how fast information is transferred.

*Absorption* is the conversion of optical power into another energy form, such as heat. *Intrinsic absorption* is caused by basic fiber-material properties. *Extrinsic absorption* is caused by impurities introduced into the fiber material.

*Silica fibers* are predominately used in fiber optic communications. They have low intrinsic material absorption at the wavelengths of operation.

The *wavelength of operation* in fiber optics is between 700 nm and 1600 nm. The wavelength of operation is between the ultraviolet (below 400 nm) and infrared (above 2000 nm) intrinsic absorption regions.

*Extrinsic absorption* occurs when impurities, such as hydroxyl ions ( $\text{OH}^-$ ), are introduced into the fiber.  $\text{OH}^-$  absorption peaks define three regions or windows of preferred operation. The first window is centered at 850 nm. The second window is centered at 1300 nm. The third window is centered at 1550 nm.

*Scattering* losses are caused by the interaction of light with density fluctuations within a fiber. Rayleigh scattering is the main source of loss in commercial fibers operating between 700 nm and 1600 nm.

*Microbends* are small microscopic bends of the fiber axis that occur mainly when a fiber is cabled. *Macrobends* are bends having a large radius of curvature relative to the fiber diameter.

*Intramodal, or chromatic, dispersion* occurs because light travels through different materials and different waveguide structures at different speeds.

*Material dispersion* is dependent on the light wavelengths interaction with the refractive index of the core. *Waveguide dispersion* is a function of the size of the fiber's core relative to the wavelength of operation.

*Intermodal, or modal, dispersion* occurs because each mode travels a different distance over the same time span.

+++