

- NOTES: (UNLESS OTHERWISE SPECIFIED)
1. THIS IS A CRYOGENIC VACUUM COMPONENT.
 2. WELDING PROCEDURE: PER VENDOR SPECIFICATION WITH LBNL APPROVAL.
 3. CLEANING PROCEDURE: PER VENDOR SPECIFICATION WITH LBNL APPROVAL.
 4. PACKAGING AND STORAGE PROCEDURE OF THE COMPONENTS: PER VENDOR SPECIFICATION WITH LBNL APPROVAL.
 5. DIMENSIONS AND TOLERANCING PER ANSI Y14.5M-1982. UNITS ARE IN INCHES [mm] UNLESS OTHERWISE SPECIFIED.
 6. USE OF SULFUR OR SILICONE BEARING OILS, LUBRICANTS, OR COOLANTS ARE STRICTLY PROHIBITED.
 7. USE OF RESIN OR RUBBER BONDED ABRASIVES UNDER POWER IS STRICTLY PROHIBITED. USE VITREOUS BONDED ABRASIVES ONLY.
 8. VENDOR SUGGESTED CHANGES TO WELD PREPS; SUBJECT TO LBNL APPROVAL.
 9. FITTINGS MAY BE USED IN PLACE OF BENDS; SUBJECT TO LBNL APPROVAL.
 10. VENDOR SUGGESTED CHANGES TO TOLERANCES TO FACILITATE FABRICATION OR ASSEMBLY; SUBJECT TO LBNL APPROVAL.
 11. REMOVE ALL THE BURRS AND REAM THE ENDS FOR CIRCULARITY AND CLEAN ENDS.
 12. TUBE END SURFACE MUST BE PERPENDICULAR TO THE TUBE AXIS WITHIN +/- .010.
 13. PERFORM ACCEPTANCE TESTS PER SECTION 3.2 OF LBNL SPECIFICATION M856.
 14. A MARK DESIGNATING THE INSTALLED LENGTH WILL BE UTILIZED DURING FINAL INSTALLATION OF THE FEEDBOX ASSEMBLY. MARK, SCRIBE OR ETCH THIS LOCATION IN A PERMANENT MANNER, SUBJECT TO LBNL APPROVAL, TO AN ACCURACY OF ± 0.063 ".
 15. PROVIDE A MINIMUM LENGTH OF 4.0" OF STRAIGHT, SMOOTH PIPE ON THE INDICATED SIDE OF THE INSTALLED LENGTH MARK FOR PIPE WELDING DURING FINAL INSTALLATION OF THE FEEDBOX ASSEMBLY.
 16. PIPE MUST BE STRAIGHT AND SMOOTH (NO BUMPS) FOR 0.5" ON EITHER SIDE OF THE CENTER-PLANE OF THE SUPPORT.
 17. CAP BOTH ENDS OF PIPE AFTER ACCEPTANCE TESTS PER SECTION 3.2 OF LBNL SPECIFICATION M856.
 18. INSTALL TEMPERATURE SENSOR PER LHC SPECIFICATION LHC-QIT-ES-0002. SENSOR TO BE PROVIDED BY LBNL.
 19. ALL PIPES TO BE INSULATED PER MLI SPECIFICATION PROVIDED BY VENDOR AND SUBJECT TO LBNL APPROVAL. IN LOCATIONS WHERE PIPES PASS THROUGH SUPPORT ASSEMBLIES, INSULATION IS TO BE WRAPPED WITH KAPTON TAPE FOR PROTECTION FROM ABRASION DURING THERMAL CYCLING.

ITEM	PART NO.	REQD	DESCRIPTION	MATERIAL
20	-	4	TUBE, PER ASTM A269	SS 304L
19	-	1	WTS MANIFOLD PIPE CAP	SS 304L
18	-	4	TUBE, PER ASTM A269	SS 304L
17	-	1	TUBE, PER ASTM A269	SS 304L
16	-	1	2-3/4 CONFLAT, MDC 110012	SS 304L
15	23M856	1	PIPE HANGER	SS 304L
14	-	1	WTS MANIFOLD HEADER, SS TUBING	SS 304L
13	-	1	TUBE, PER ASTM A269	SS 304L
11	-	1	TUBE, PER ASTM A269	SS 304L
9	-	1	Ø5/16" X 1/16" FLAT PLATE ORIFICE	SS 304L
3	-	4	BRAIDED FLEX HOSE, 1/2" ID X 2.3" ILL	SS 300 SERIES
2	-	1	BRAIDED FLEX HOSE, 1" ID X 5" ILL	SS 300 SERIES
1	-	1	CERNOX, TEMP SENSOR	

REV	DATE	BY	CHKD	ZONE	DATE	CHANGES
A	11/18/02	JDR	SPV			INITIAL RELEASE

ERNEST ORLANDO LAWRENCE
BERKELEY NATIONAL LABORATORY
 UNIVERSITY OF CALIFORNIA - BERKELEY
 LHC IR FEEDBOX
 CRYOGENICS
 DH VENT PIPE

MICROFILMED: []
 DWG. TYPE: ASSEM
 SHOWN ON: []
 SCALE: 1/4
 SHEET 1 OF 2
 DESIGN ACCT. NO: ZSLCE2
 CATEGORY CODE: LH2003
 DWG. NO: 2516346
 DATE: 12-MAY-02
 DATE: 8-NOV-02
 DATE: 25-JUL-02

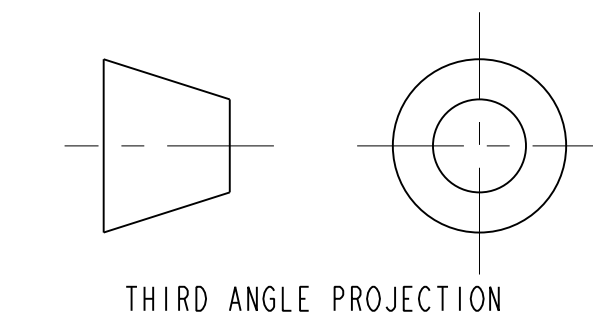

2516346 A 1
 11/18/02 JDR

8 7 6 5 4 3 2 1

D

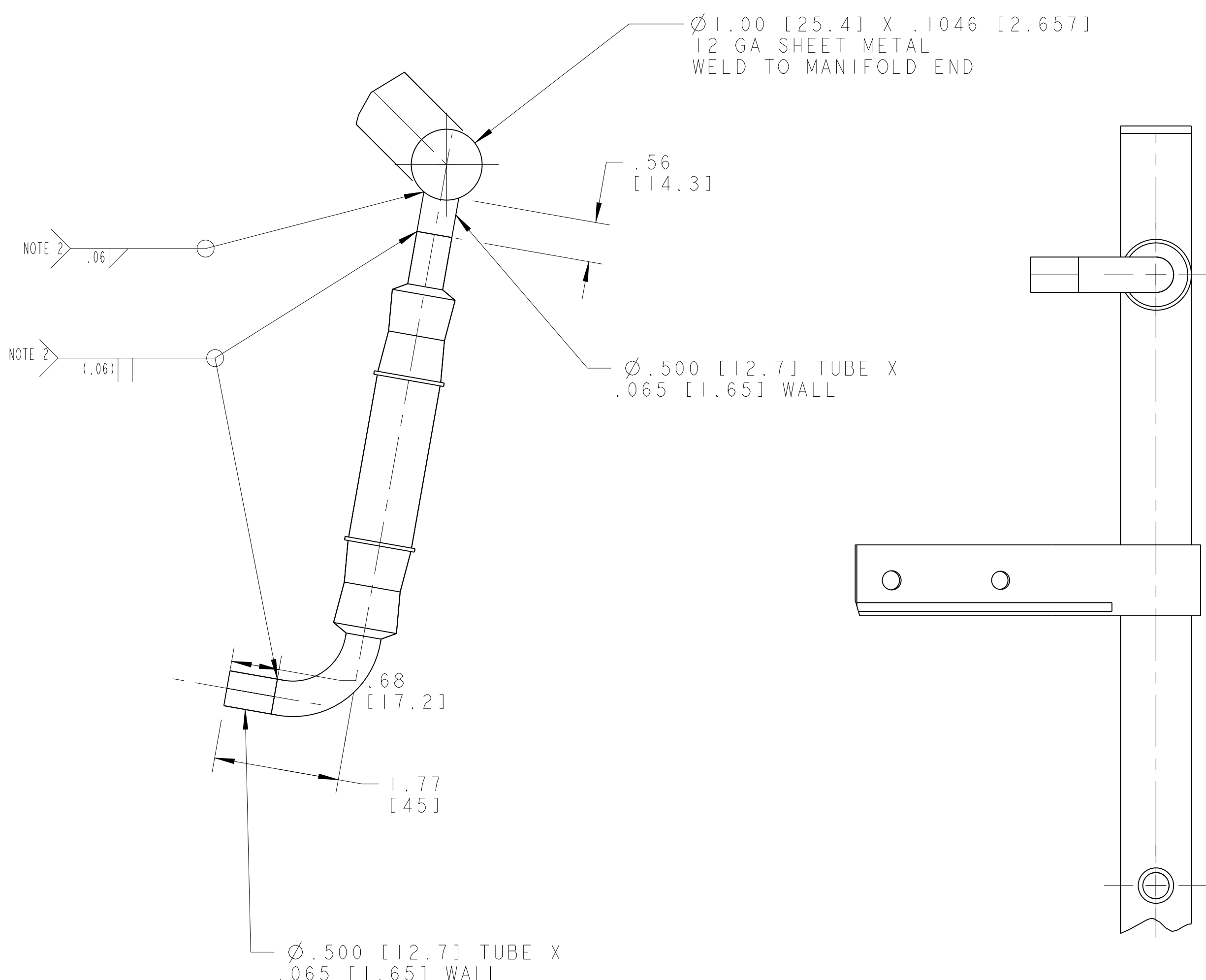

DETAIL D
SCALE 3/4

AUXILIARY VIEW OF PIPE
SCALE 3/4

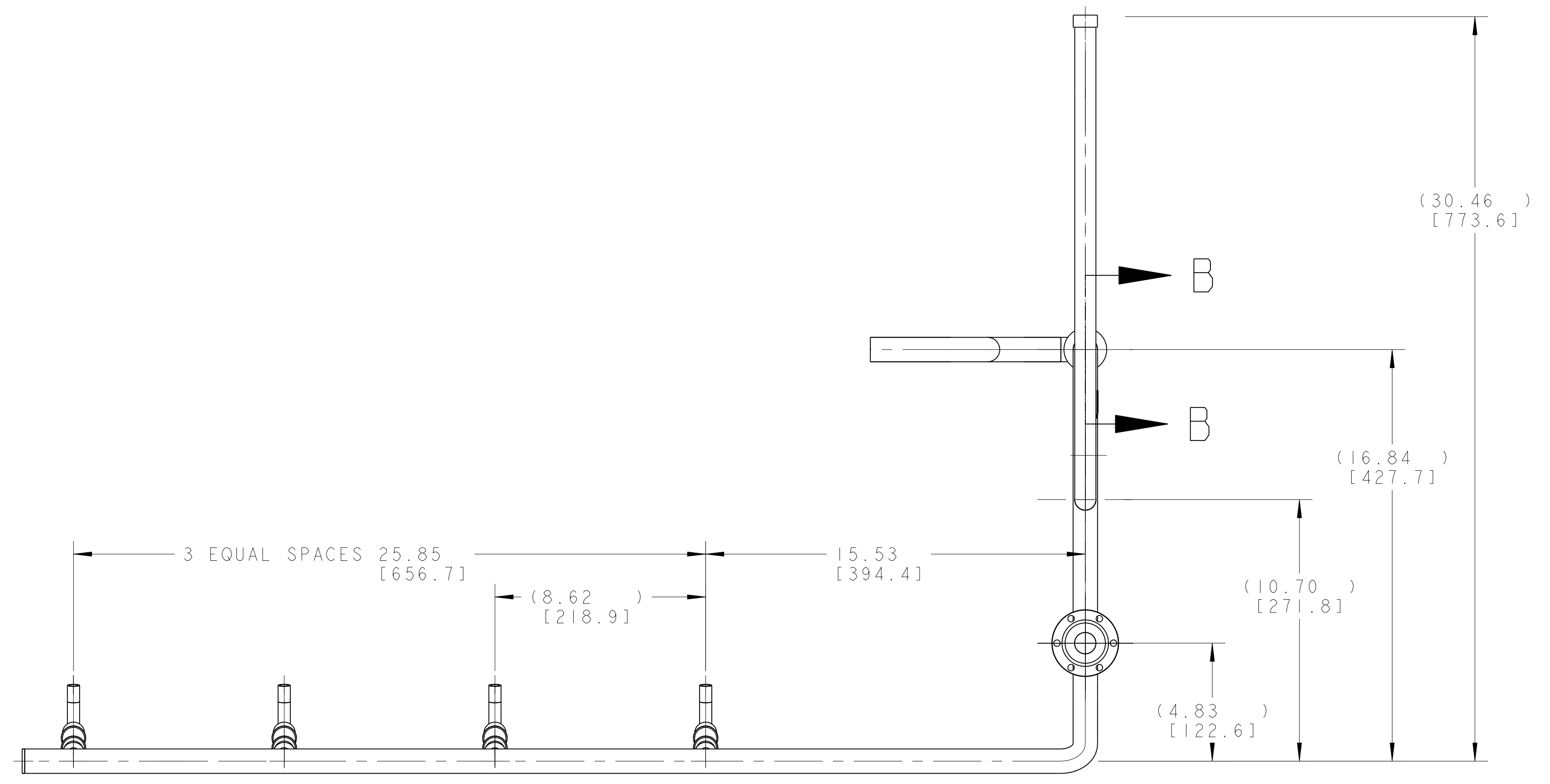

C

C

B

B

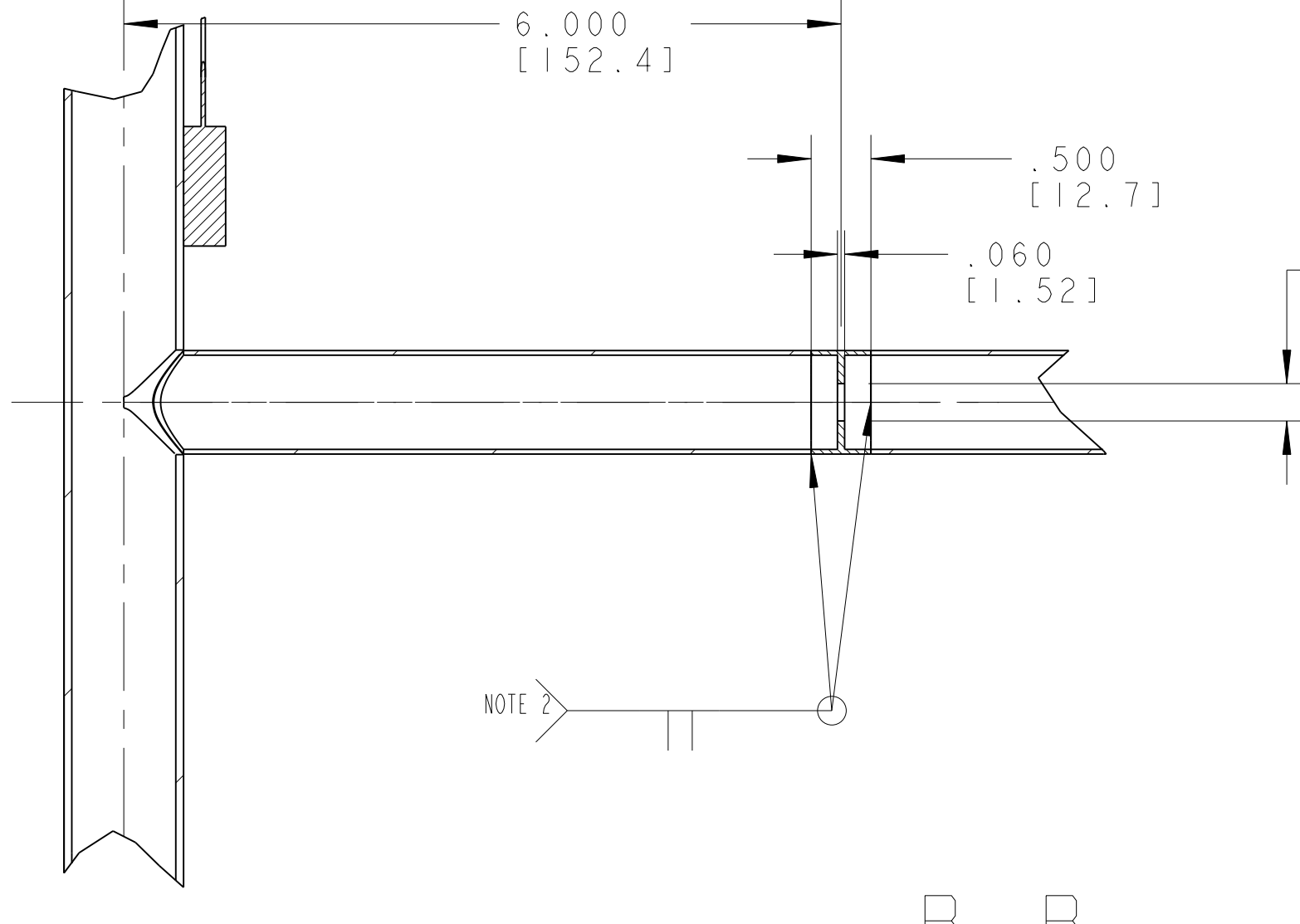
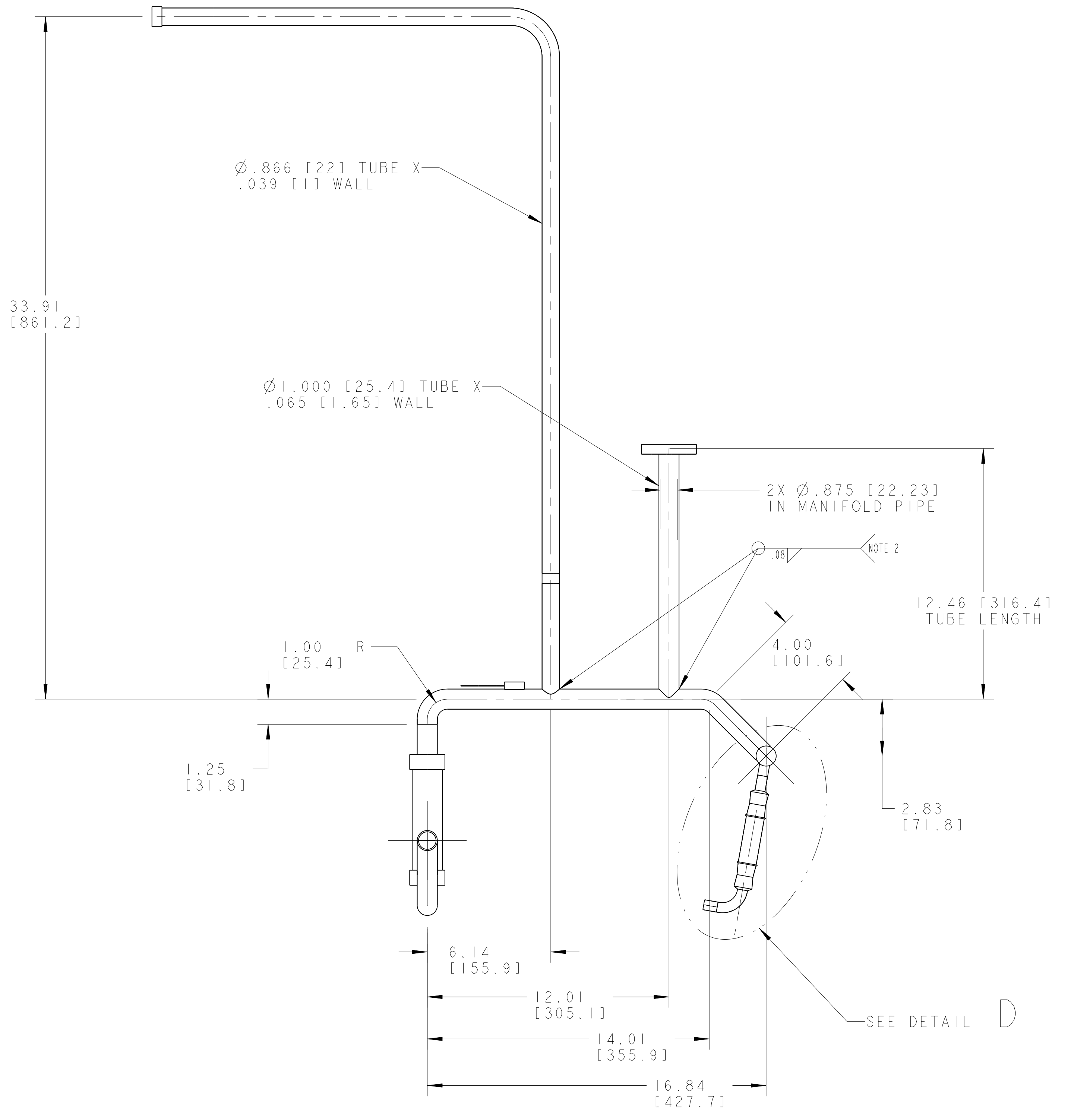

SECTION B-B
SCALE 3/4

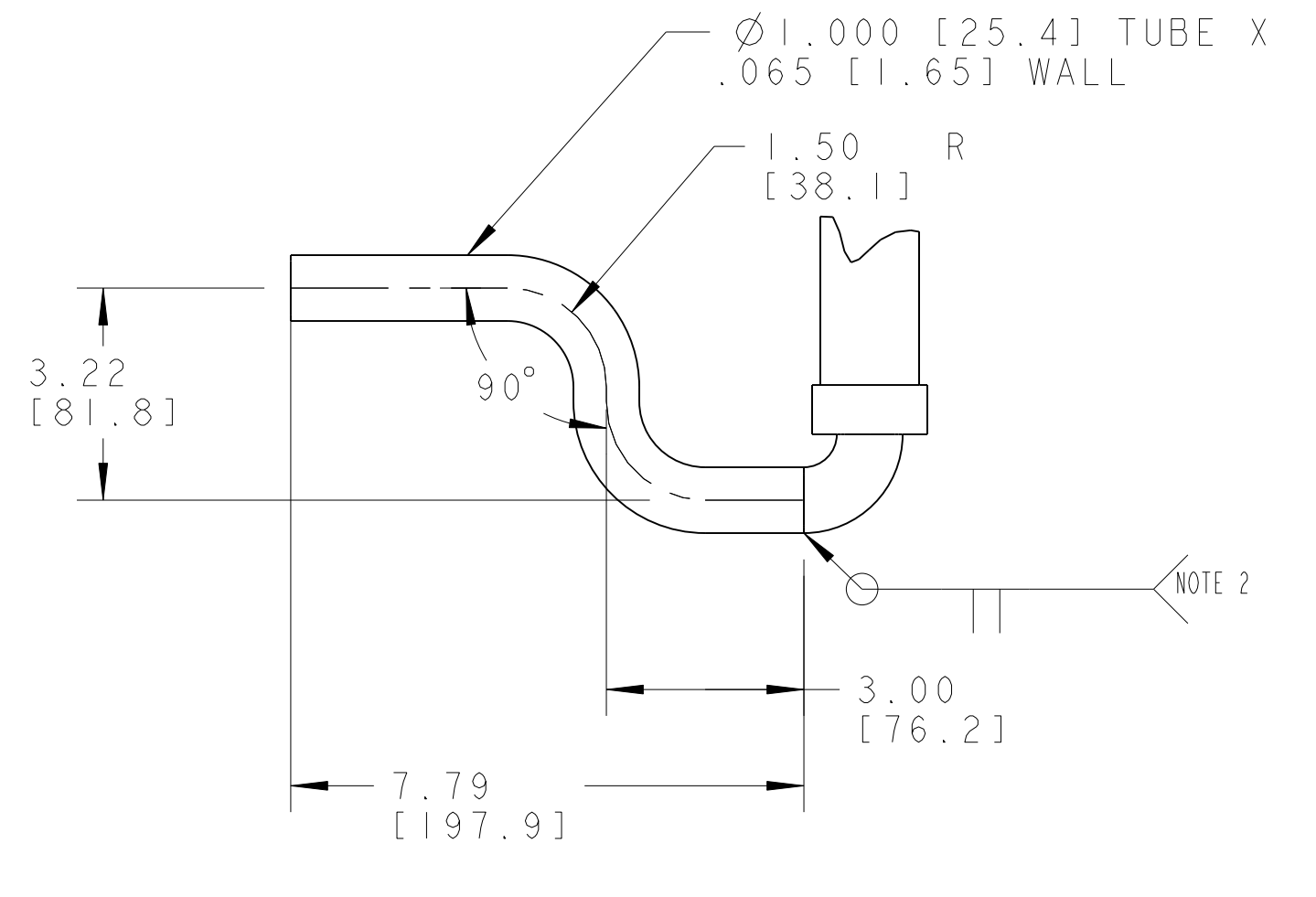

DETAIL E
SCALE 3/8

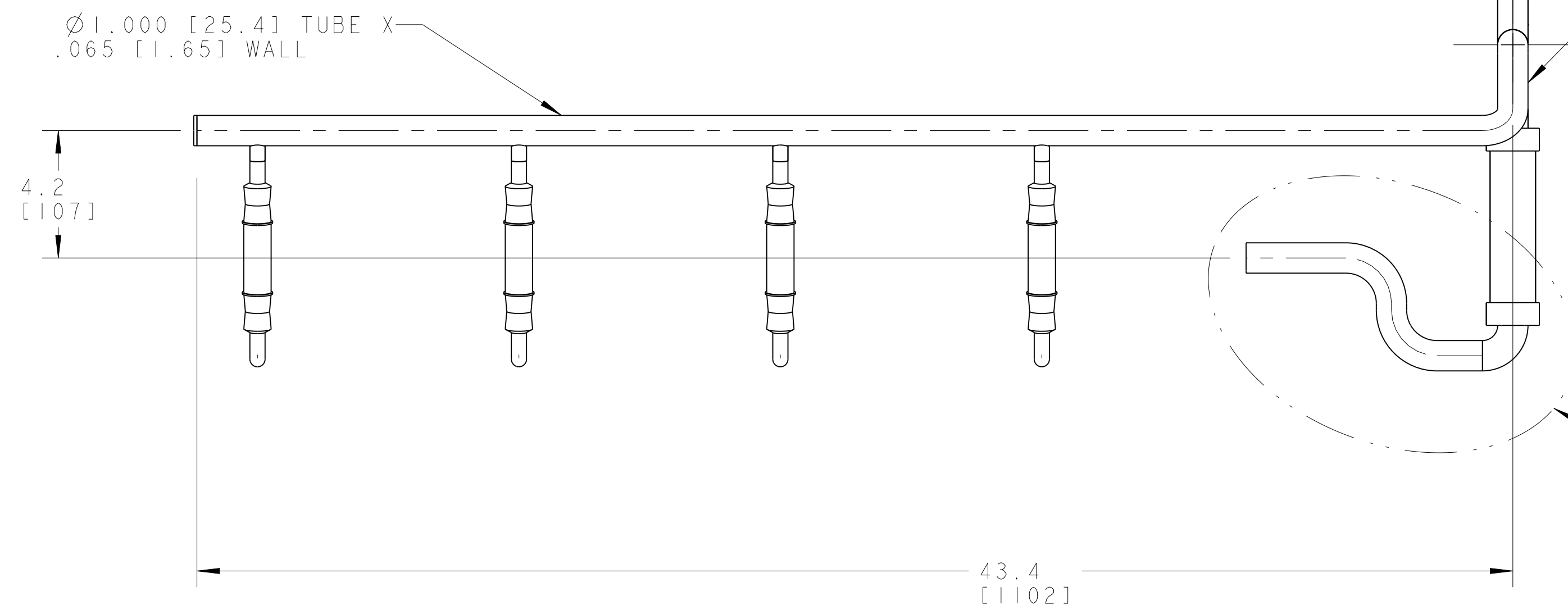

A

A

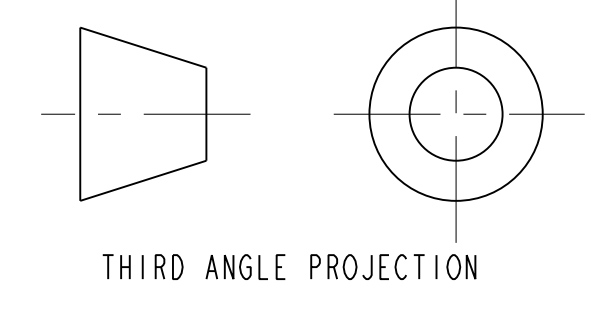

ERNEST ORLANDO LAWRENCE BERKELEY NATIONAL LABORATORY UNIVERSITY OF CALIFORNIA - BERKELEY			
LHC IR FEEDBOX CRYGENICS DH VENT PIPE			
MICROFILMED:	DWG. TYPE:	SHOWN ON:	SCALE: 9/32
PATENT CLEAR:	DESIGN ACCT. NO:	CATEGORY CODE:	DWG. NO. 2516346
	ZSLCE2	LH2003	SHEET 2 OF 2
			SIZE: REV. A

8 7 6 5 4 3 2 1

2516346 A 2