

8 7 6 5 4 3 2 1

D

C

B

A

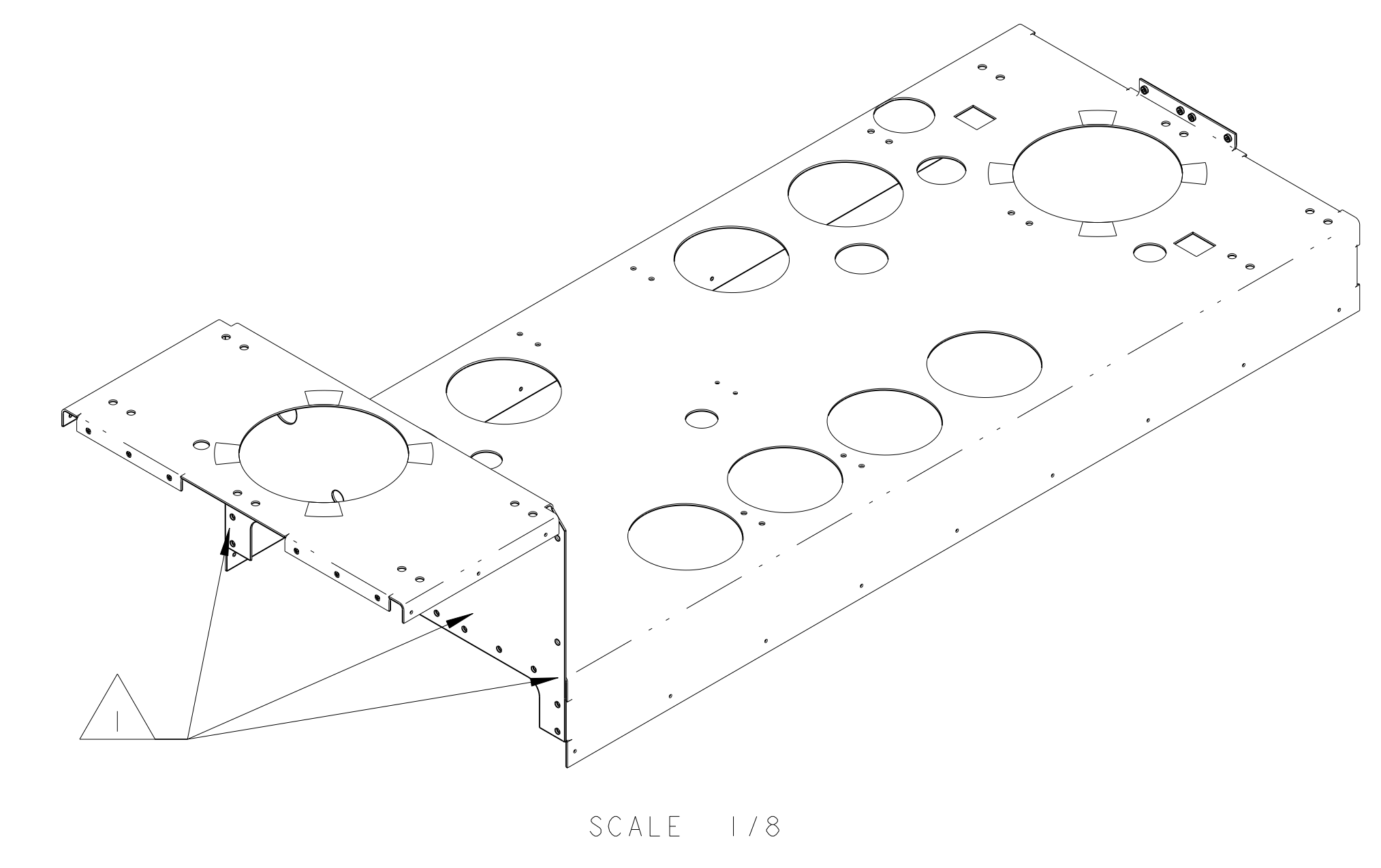
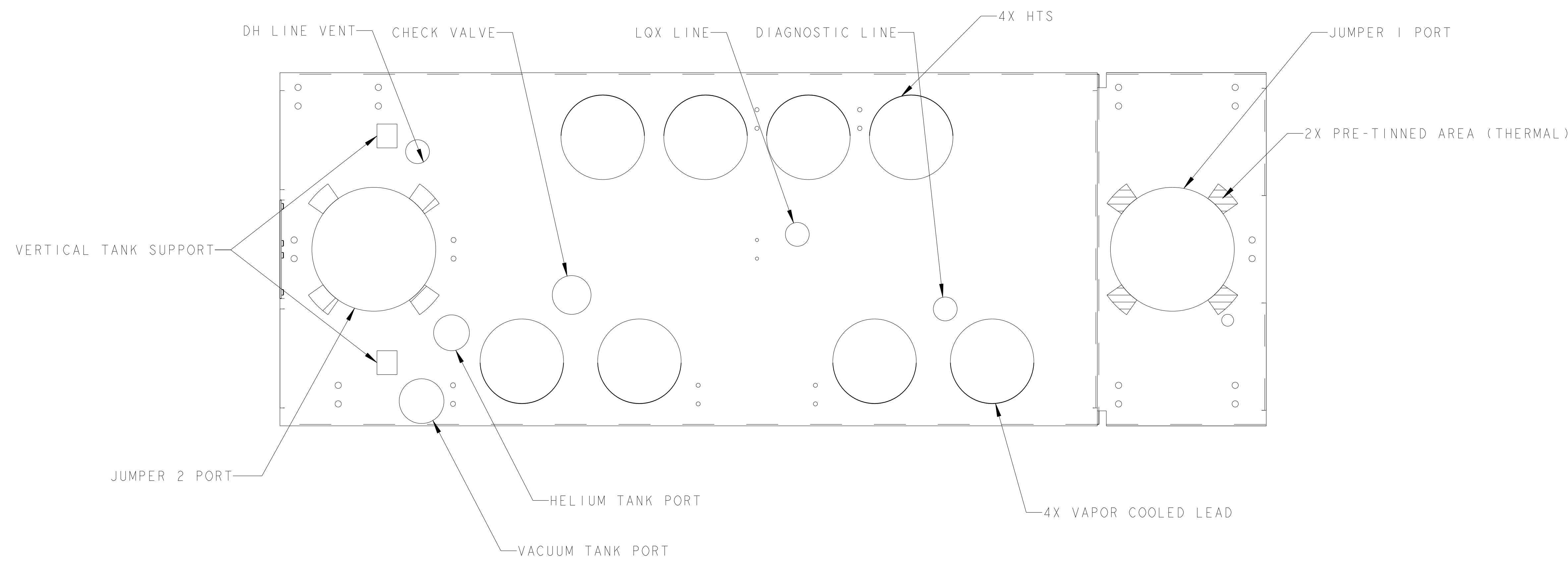

SCALE 1/8

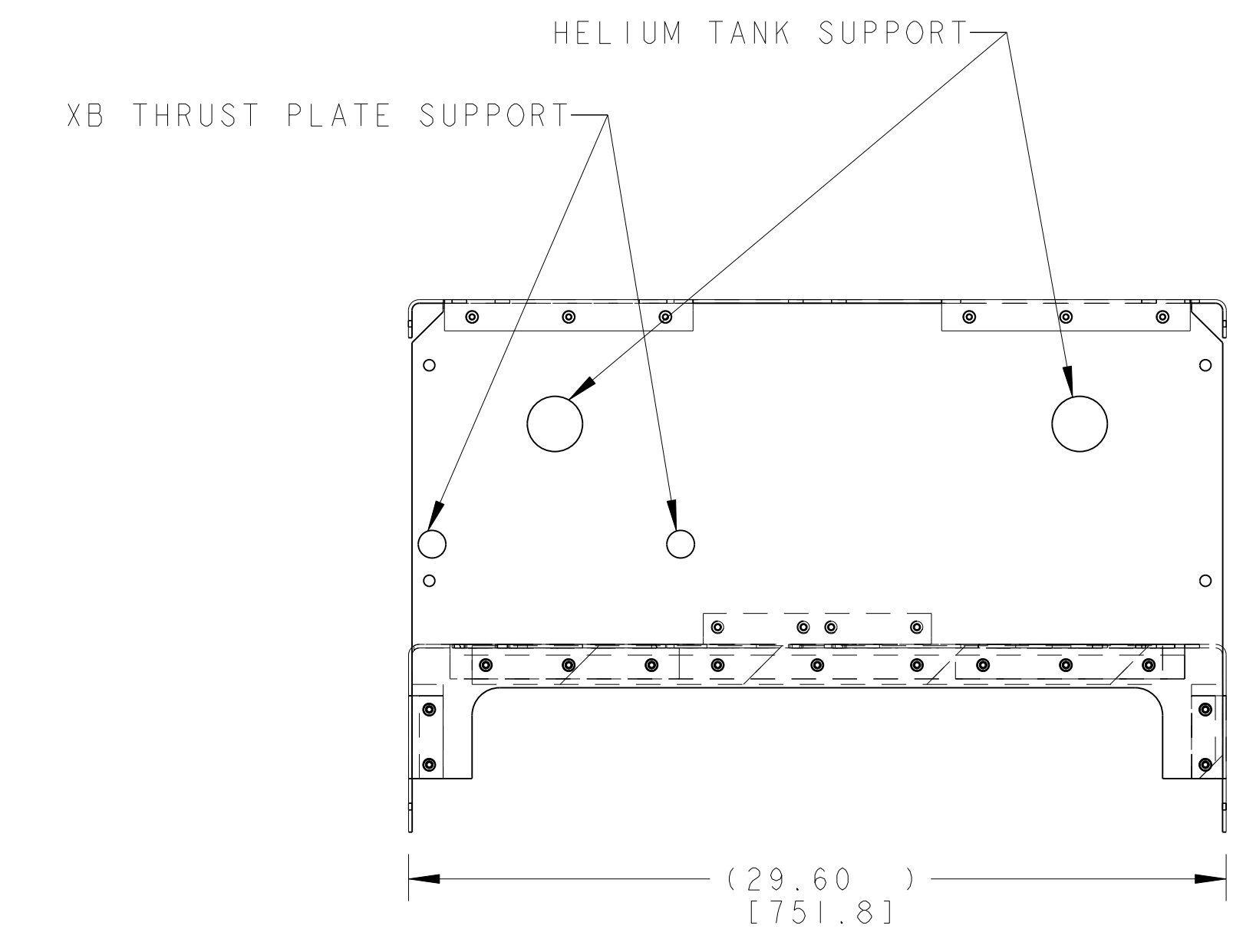
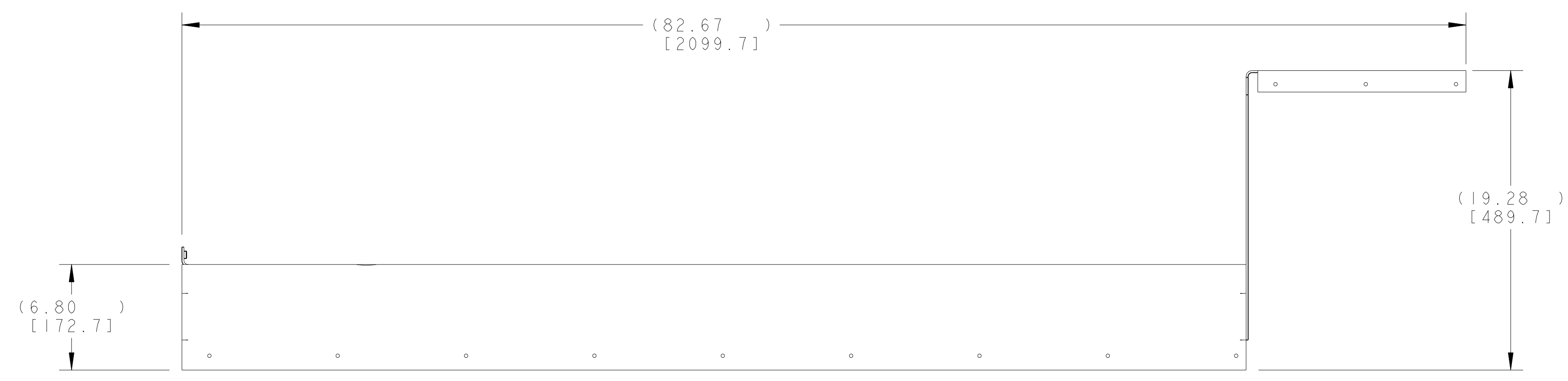

NOTES: (UNLESS OTHERWISE SPECIFIED)

1. ITEMS 1 AND 2 ASSEMBLED WITH FASTENERS IN NEXT ASSEMBLY, THEN RE-FLOW SOLDER FOR THERMAL CONDUCTIVITY.
2. THIS IS A CRYOGENIC VACUUM COMPONENT.
3. WELDING PROCEDURE: PER VENDOR SPECIFICATION WITH LBNL APPROVAL.
4. CLEANING PROCEDURE: PER VENDOR SPECIFICATION WITH LBNL APPROVAL.
5. PACKAGING AND STORAGE PROCEDURE OF THE COMPONENTS: PER VENDOR SPECIFICATION WITH LBNL APPROVAL.
6. DIMENSIONS AND TOLERANCING PER ANSI Y14.5M-1982. UNITS ARE IN INCHES [mm] UNLESS OTHERWISE SPECIFIED.
7. USE OF SULFUR OR SILICONE BEARING OILS, LUBRICANTS, OR COOLANTS ARE STRICTLY PROHIBITED.
8. USE OF RESIN OR RUBBER BONDED ABRASIVES UNDER POWER IS STRICTLY PROHIBITED. USE VITREOUS BONDED ABRASIVES ONLY.
9. PROTECT FINISHED PART BY BAGGING OR SIMILAR METHOD TO PROTECT AND MAINTAIN CLEANLINESS DURING SHIPMENT AND STORAGE.

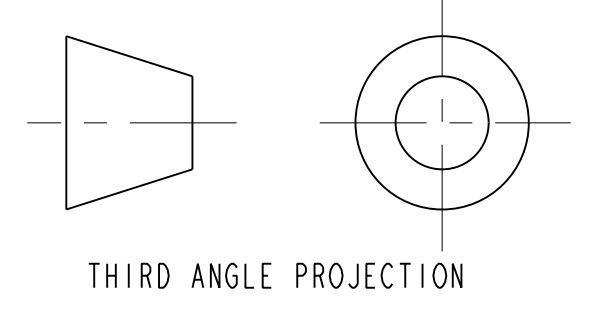
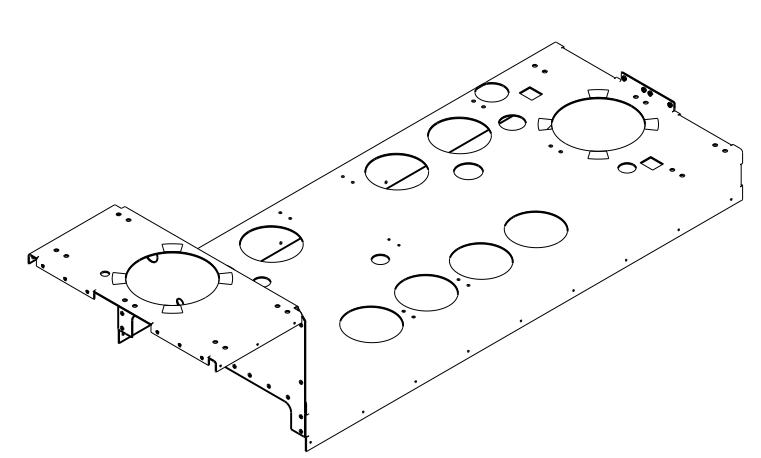

THIRD ANGLE PROJECTION

REV	DWG	CHK	ZONE	DATE	INITIAL RELEASE	CHANGES
A	JDR	DPO		11-04-02	INITIAL RELEASE	

ITEM	PART NO.	RECD	DESCRIPTION	MATERIAL
2	251878	1	TOP SHIELD, DFBXB/DFBXD/DFBHH/DFBKE	COPPER, OFHC, C101
1	251628	1	TOP COVER, NEGATIVE SD, DFBXC/DFBXG	COPPER, OFHC, C101

**ERNEST ORLANDO LAWRENCE**  
**BERKELEY NATIONAL LABORATORY**  
 UNIVERSITY OF CALIFORNIA - BERKELEY

LHC IR FEEDBOX  
 CRYOGENICS  
 THERMAL SHIELD ASSY, DFBXB

MICROFILMED: [ ] DWG. TYPE: ASSEM SHOWN ON: [ ]  
 SCALE: 3/16 SHEET 1 OF 1  
 PATENT CLEAR: [ ] DESIGN ACCT. NO: Z5LCE2 CATEGORY CODE: LH2003  
 DWG. NO.: 2515946

8 7 6 5 4 3 2 1

2515946 A 1