

8 7 6 5 4 3 2 1

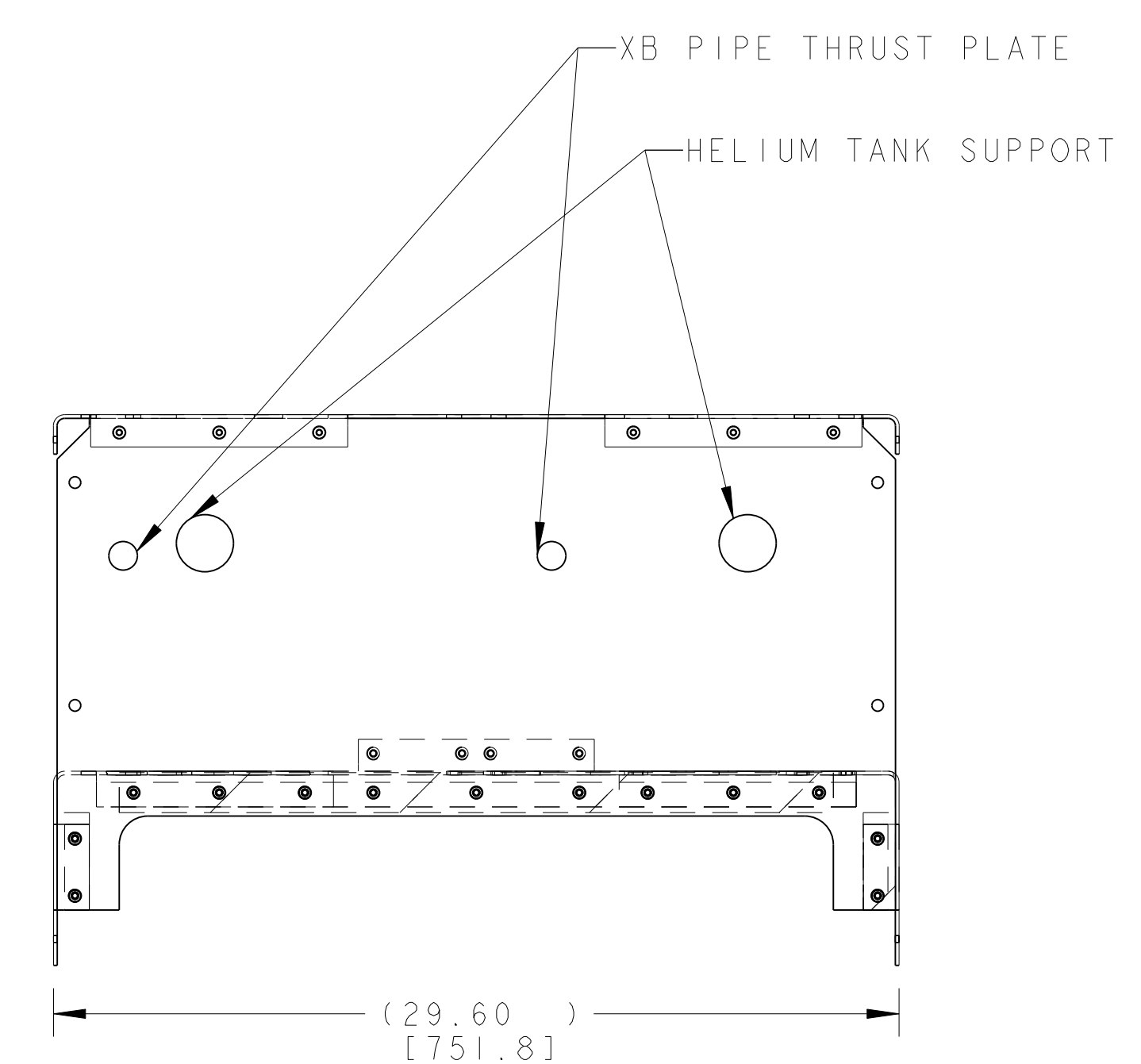

NOTES: (UNLESS OTHERWISE SPECIFIED)

1. ITEMS 1 AND 2 ASSEMBLED WITH FASTENERS IN NEXT ASSEMBLY, THEN RE-FLOW SOLDER FOR THERMAL CONDUCTIVITY.
2. THIS IS A CRYOGENIC VACUUM COMPONENT.
3. WELDING PROCEDURE: PER VENDOR SPECIFICATION WITH LBNL APPROVAL.
4. CLEANING PROCEDURE: PER VENDOR SPECIFICATION WITH LBNL APPROVAL.
5. PACKAGING AND STORAGE PROCEDURE OF THE COMPONENTS: PER VENDOR SPECIFICATION WITH LBNL APPROVAL.
6. DIMENSIONS AND TOLERANCING PER ANSI Y14.5M-1982. UNITS ARE IN INCHES [mm] UNLESS OTHERWISE SPECIFIED.
7. USE OF SULFUR OR SILICONE BEARING OILS, LUBRICANTS, OR COOLANTS ARE STRICTLY PROHIBITED.
8. USE OF RESIN OR RUBBER BONDED ABRASIVES UNDER POWER IS STRICTLY PROHIBITED. USE VITREOUS BONDED ABRASIVES ONLY.
9. PROTECT FINISHED PART BY BAGGING OR SIMILAR METHOD TO PROTECT AND MAINTAIN CLEANLINESS DURING SHIPMENT AND STORAGE.

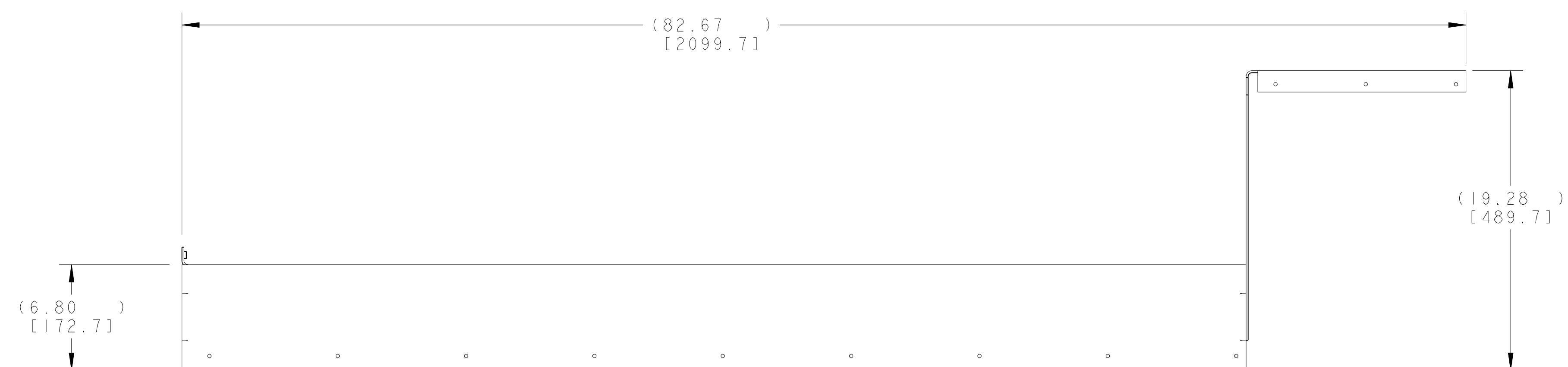
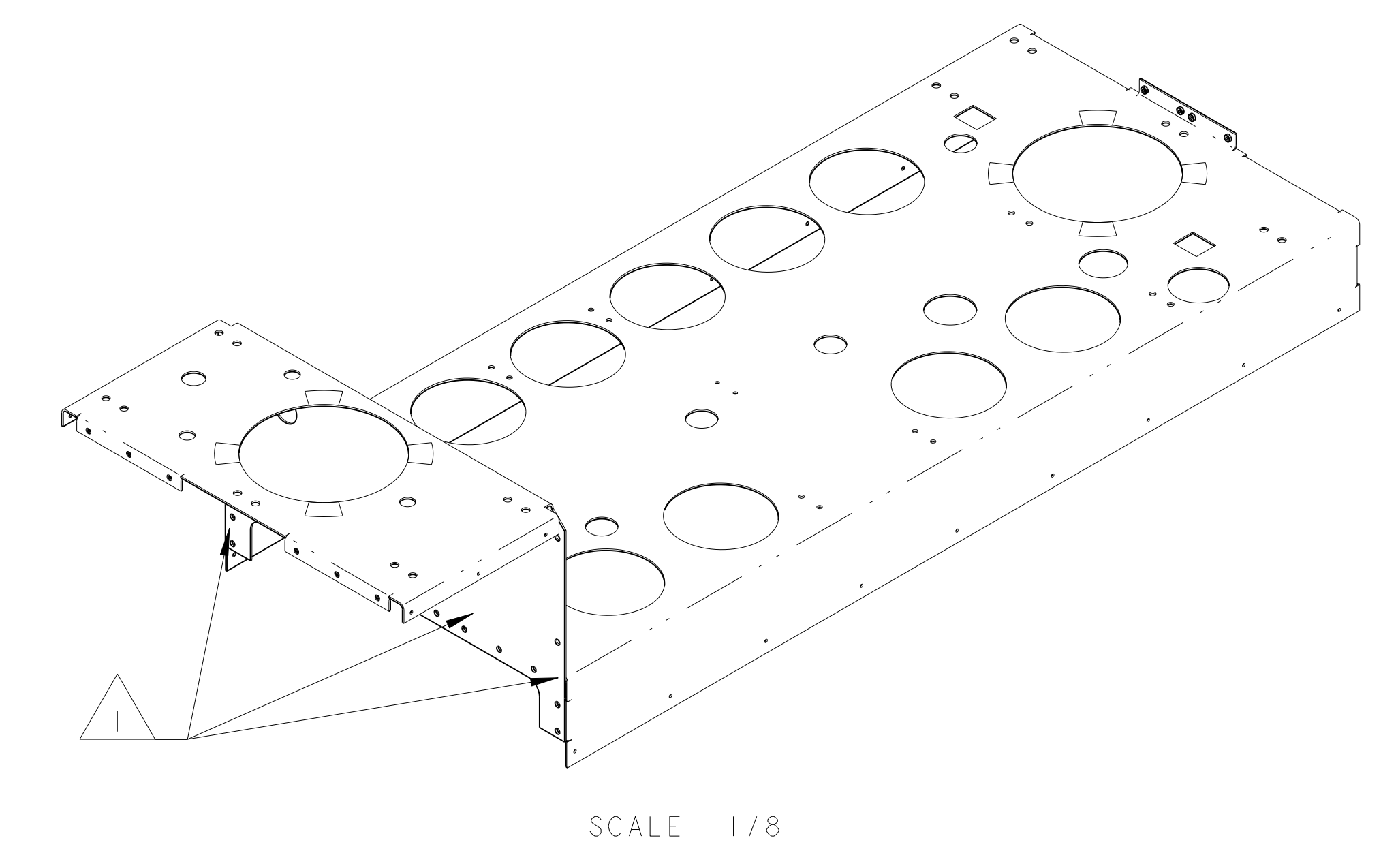
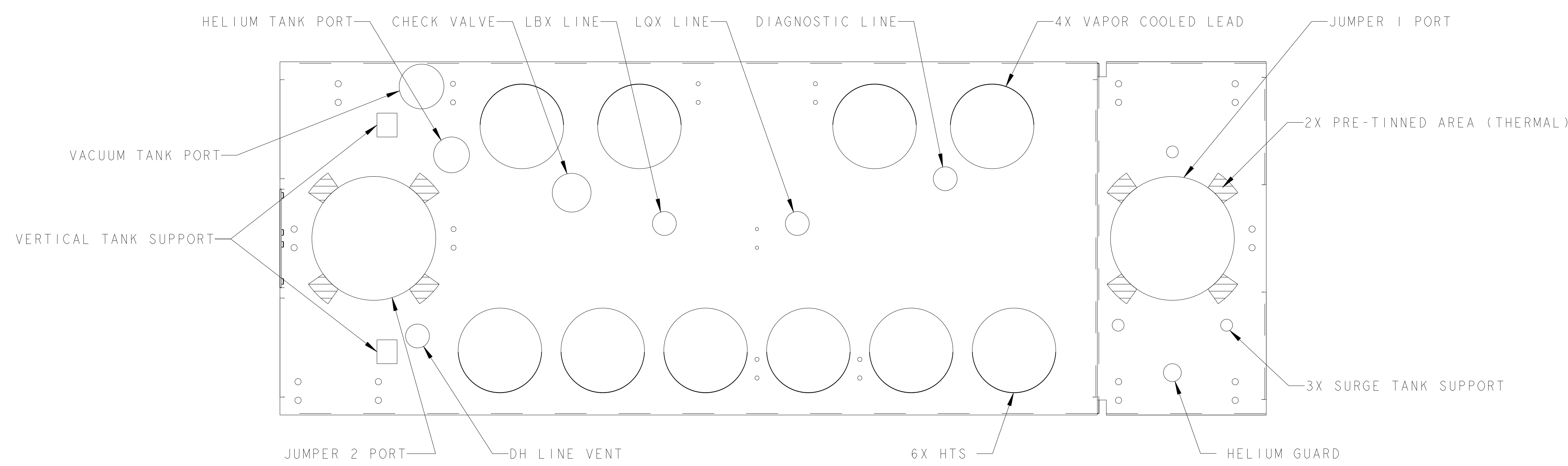
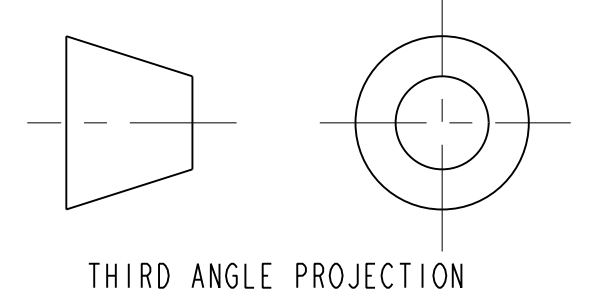

REV	DWG	CHK	ZONE	DATE	CHANGES
B	JDR	DPO		11-08-02	CHANGED MATERIAL CALLOUT, MOVED CHECK VALVE PORT ADDED 10 THRUST PLATE HOLES
A	ARH	DPO		09-09-02	INITIAL RELEASE

ITEM	PART NO.	RECD	DESCRIPTION	MATERIAL
2	251071	1	TOP SHIELD, DFBXA/DFBXC/DFBYG	COPPER, OFHC, C101
1	251069	1	TOP COVER, NEGATIVE SD, DFBXC/DFBYG	COPPER, OFHC, C101

ERNEST ORLANDO LAWRENCE  
BERKELEY NATIONAL LABORATORY  
UNIVERSITY OF CALIFORNIA - BERKELEY

LHC IR FEEDBOX  
CRYOGENICS

THermal SHIELD ASSY, DFBXC/DFBYG

SCALE: 3/16

SHEET 1 OF 1

2515906

8 7 6 5 4 3 2 1

2515906 B 1