

NOTES: (UNLESS OTHERWISE SPECIFIED)

1. THIS IS A CRYOGENIC VACUUM COMPONENT.
2. WELDING PROCEDURE: PER VENDOR SPECIFICATION WITH LBNL APPROVAL.
3. CLEANING PROCEDURE : PER VENDOR SPECIFICATION WITH LBNL APPROVAL.
4. PACKAGING AND STORAGE PROCEDURE OF THE COMPONENTS: PER VENDOR SPECIFICATION WITH LBNL APPROVAL.
5. DIMENSIONS AND TOLERANCING PER ANSI Y14.5M-1982. UNITS ARE IN INCHES [mm] UNLESS OTHERWISE SPECIFIED.
6. USE OF SULFUR OR SILICONE BEARING OILS, LUBRICANTS, OR COOLANTS ARE STRICTLY PROHIBITED.
7. USE OF RESIN OR RUBBER BONDED ABRASIVES UNDER POWER IS STRICTLY PROHIBITED. USE VITREOUS BONDED ABRASIVES ONLY.
8. VENDOR SUGGESTED CHANGES TO WELD PREPS; SUBJECT TO LBNL APPROVAL.
9. FITTINGS MAY BE USED IN PLACE OF BENDS; SUBJECT TO LBNL APPROVAL.
10. VENDOR SUGGESTED CHANGES TO TOLERANCES TO FACILITATE FABRICATION OR ASSEMBLY; SUBJECT TO LBNL APPROVAL.
11. REMOVE ALL THE BURRS AND REAM THE ENDS FOR CIRCULARITY AND CLEAN ENDS.
12. TUBE END SURFACE MUST BE PERPENDICULAR TO THE TUBE AXIS WITHIN +/- .010.
13. PERFORM ACCEPTANCE TESTS PER SECTION 3.2 OF LBNL SPECIFICATION M856.
14. A MARK DESIGNATING THE INSTALLED LENGTH WILL BE UTILIZED DURING FINAL INSTALLATION OF THE FEEDBOX ASSEMBLY. MARK, SCRIBE OR ETCH THIS LOCATION IN A PERMANENT MANNER, SUBJECT TO LBNL APPROVAL, TO AN ACCURACY OF ±0.063".
15. PROVIDE A MINIMUM LENGTH OF 4.0" OF STRAIGHT, SMOOTH PIPE ON THE INDICATED SIDE OF THE INSTALLED LENGTH MARK FOR PIPE WELDING DURING FINAL INSTALLATION OF THE FEEDBOX ASSEMBLY.
16. PIPE MUST BE STRAIGHT AND SMOOTH (NO BUMPS) FOR 0.5" ON EITHER SIDE OF THE CENTER-PLANE OF THE SUPPORT.
17. CAP BOTH ENDS OF PIPE AFTER ACCEPTANCE TESTS PER SECTION 3.2 OF LBNL SPECIFICATION M856.
18. INSTALL TEMPERATURE SENSOR PER LHC SPECIFICATION LHC-OIT-ES-0002. SENSOR TO BE PROVIDED BY LBNL.

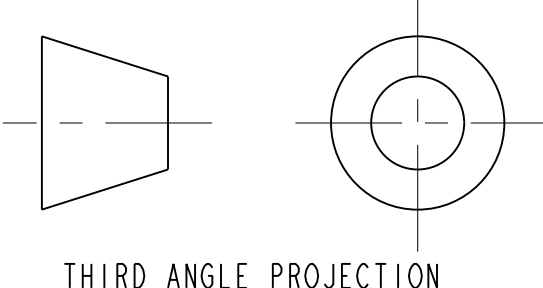

UNLESS OTHERWISE SPECIFIED	SEE	
X.X ± 0.1	FRACTION	1/64
X.XX ± 0.03	ANGLE	1.00°
X.XXX ± 0.010	FINISH	125
DO NOT SCALE PRINT		
TOLERANCES ARE CLASS 2		
CHAMFER ENDS OF ALL SCREEN THREADS 30°		
CUT ROUNDS, 1.5 THREAD RELIEF ON MACHINED THREADS		
BREAK EDGES .016 MAX. ON MACHINED WORK		
REMOVE BURRS, WELD SPATTER & LOOSE SCALE		
IN ACCORDANCE WITH SEMI H14.3M & B.6.1		

REV	DATE	BY	CHK	ZONE	DATE	INITIAL RELEASE CHANGES
A	ARH	DPO	P-16	02		

SHOP ORDERS		REV	DATE	BY	CHK	ZONE	DATE
1		1	07-Dec-01	Jan Zbasnik			
2		1	4-02-02	Jan Zbasnik			

ITEM	PART NO	REQD	DESCRIPTION	MATERIAL
32	-	1	PIPE, PER ASTM A312	SS 304L
31	251913	2	SUPPORT BRACKET, SURGE TANK	SS 304L
30	-	1	TUBE, PER ASTM A269	SS 304L
29	251840	1	HEATER TUBE	SS 304L
28	251551	1	TRANSOUCEUR TUBING	SS 304L
27	251549	1	PIPE, XB, SURGE TANK ATTACHMENT	SS 304L
26	251548	1	PIPE, CY11	SS 304L
25	251547	1	SURGE TANK BODY	SS 304L
24	251358	1	SURGE TANK BOTTOM	SS 304L
23	251357	1	SURGE TANK TOP	SS 304L
22	251220	1	PIPE, XB, SURGE TANK ATTACHMENT	SS 304L
21	25M821	1	XB BELLOWS SUPPORT BRACKET	SS 304L
20	25M828	1	XB VERTICAL SUPPORT BRACKET	SS 304L
19	25M862	1	WELD BRACKET	SS 304L
18	251314	1	BELLOWS, FINAL# 5520-MD-390065	SS 309 SERIES
17	251306	1	FLANGE, FINAL# 5520-MC-390032	SS 309 SERIES
16	25M877	1	CLAMP BASE PLATE, 5/8 TUBE X 5.00"	OFHC C101
15	251426	1	CLAMP BASE PLATE	OFHC C101
14	25M826	1	XB HANGER, ANGLE PLATE	304 SS
13	-	1	1/2" FLAT WASHER	18-8 SS
12	-	1	1/2" HEX NUT	18-8 SS
11	-	1	HEX HD BOLT, 1/2-13 X 1-1/4 LG	18-8 SS
10	-	1	STANDARD BRAIDED COPPER CABLE 4"	-
9	-	1	CERNOX, TEMP SENSOR	-
8	-	1	CERNOX, TEMP SENSOR	-
7	25M863	1	XB BELLOWS SUPPORT BRACKET	-
6	25M810	1	THRUST SUPPORT WITH THERMAL BREAK	-
5	25M810	1	THRUST SUPPORT WITH THERMAL BREAK	-
4	25H413	3	THRUST SUPPORT WITH THERMAL BREAK	-
3	25M814	1	WELD RING, ID 134mm, FINAL SUPPLIED	-
2	25M814	1	CLAMP COVER 4"	OFHC, C101
1	25M813	1	CLAMP COVER 1"	OFHC, C101

ERNEST ORLANDO LAWRENCE  
BERKELEY NATIONAL LABORATORY  
UNIVERSITY OF CALIFORNIA BERKELEY

LHC IR FEEDBOX  
CRYOGENICS  
PIPE, XB DFBXF

SCALE: 1/4  
SHEET 1 OF 3  
REV: A

NAME: ARJARRIS OBJECT: 251545.2 DATE: 02-Dec-02 13:50:30

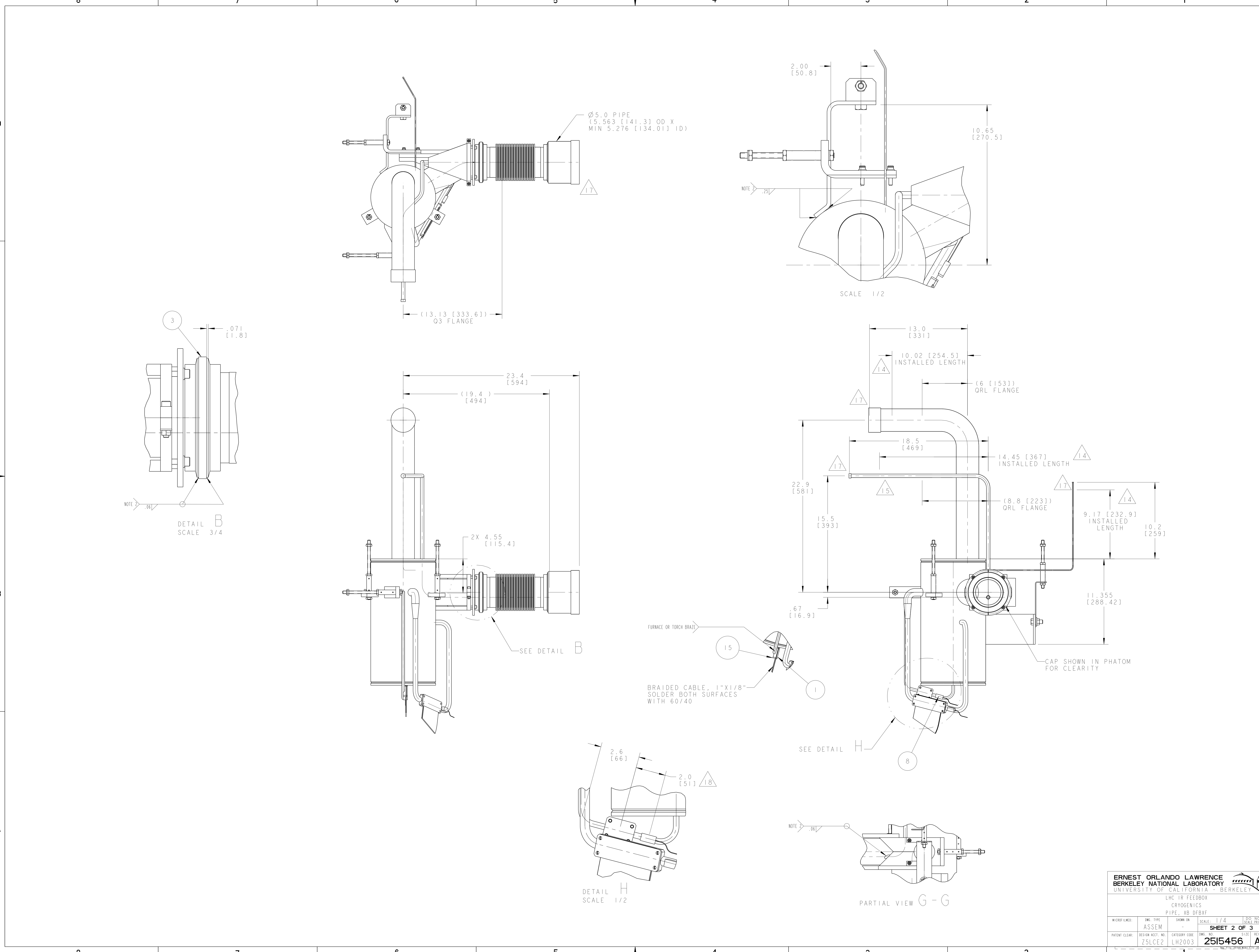

<b>ERNEST ORLANDO LAWRENCE</b> <b>BERKELEY NATIONAL LABORATORY</b> <small>UNIVERSITY OF CALIFORNIA BERKELEY</small>			
LHC IR FEEDBOX CRYOGENICS PIPE, XB DFBXF			
MICROFILMED:	ENG. TYPE:	SHOW ON:	SCALE: 1/4
	ASSEM		
PATENT CLEAR:	REVISION NO.:	CATEGORY CODE:	ENG. NO.:
	Z5LCE2	LH2003	2515456
			<b>SHEET 2 OF 3</b>
			SIZE: REV: A

2515456 A 2

8

7

6

5

4

3

2

1

D

C

B

A

D

C

B

A

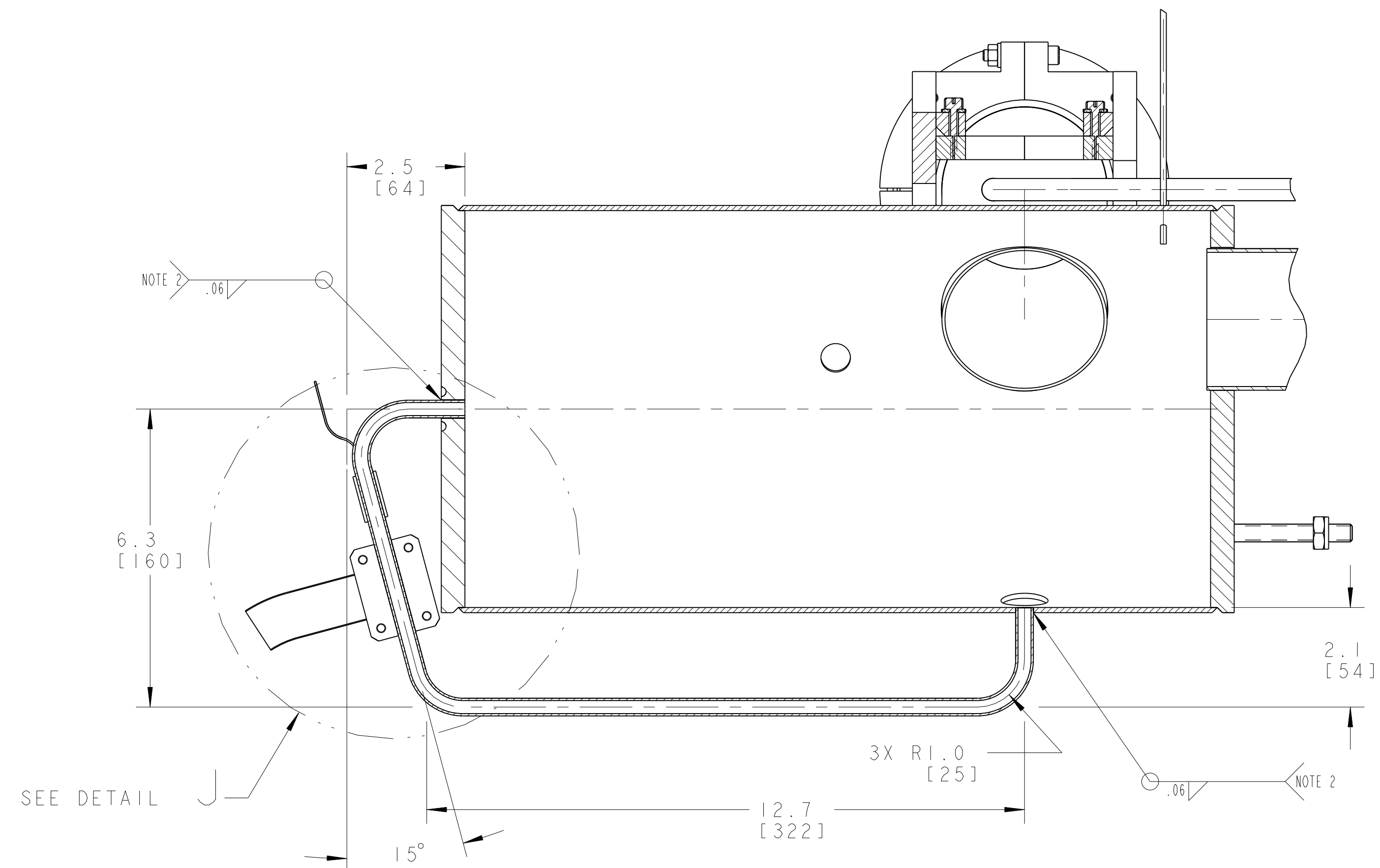

SECTION D-D  
SCALE 1/2

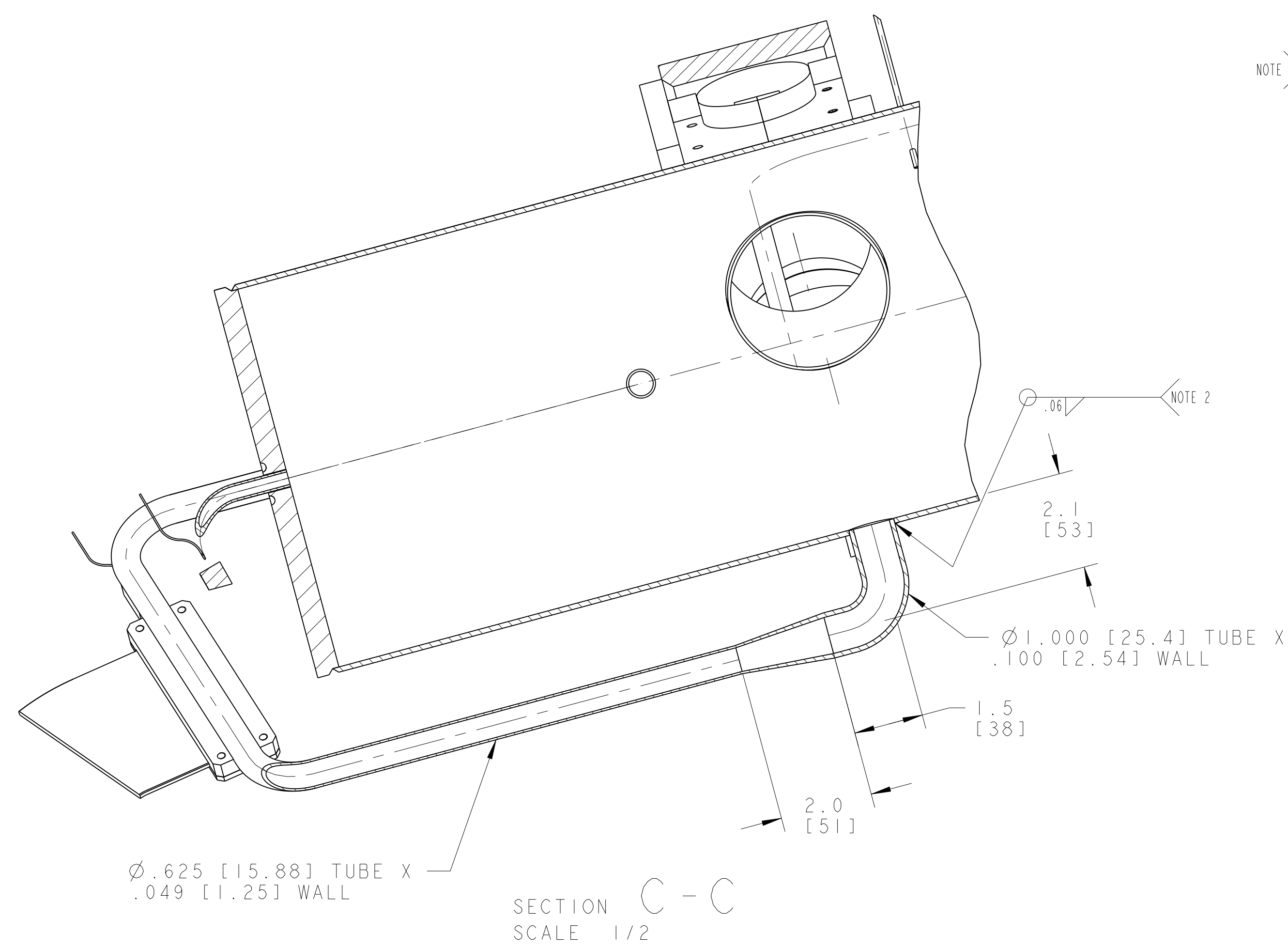
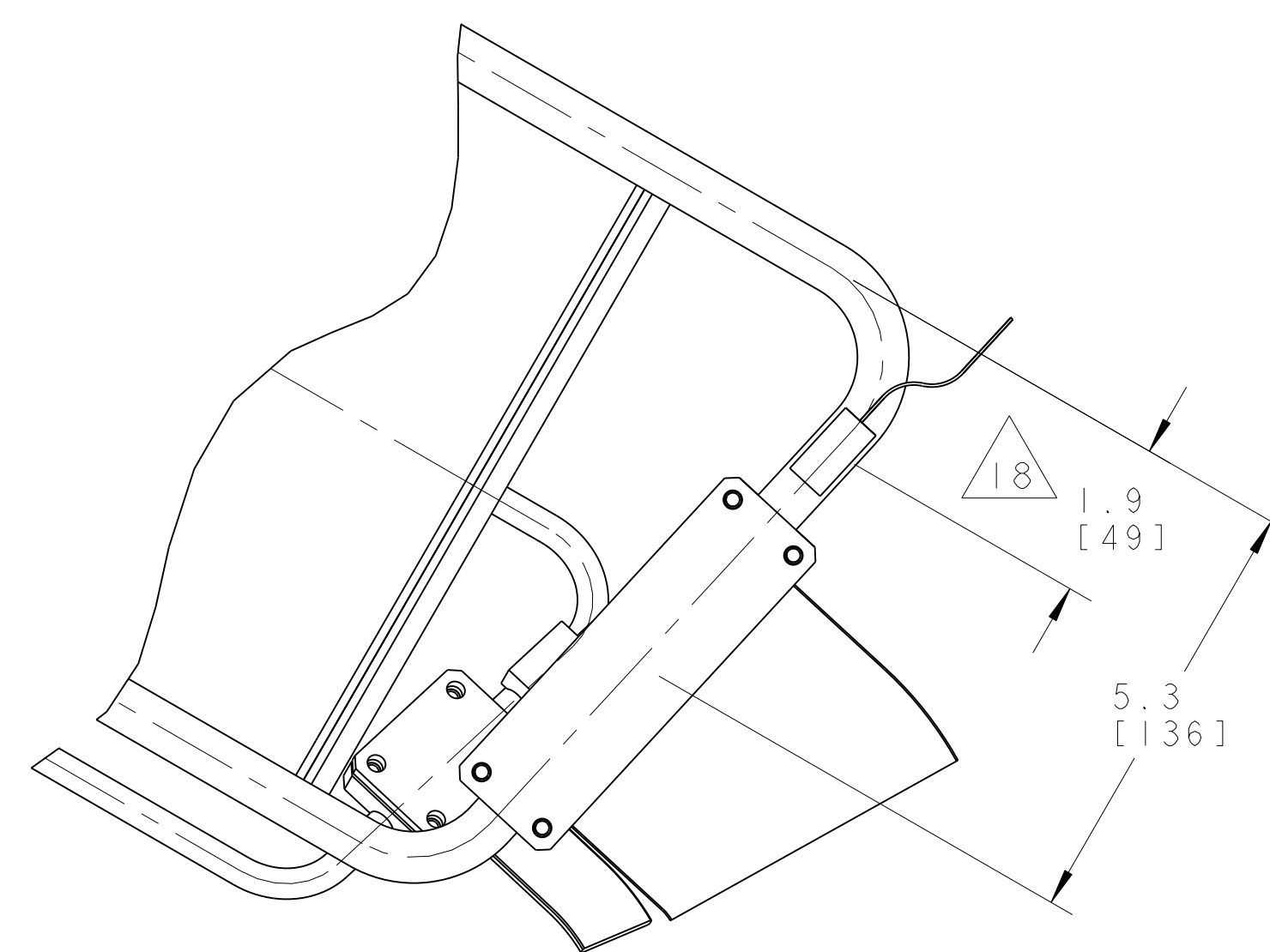
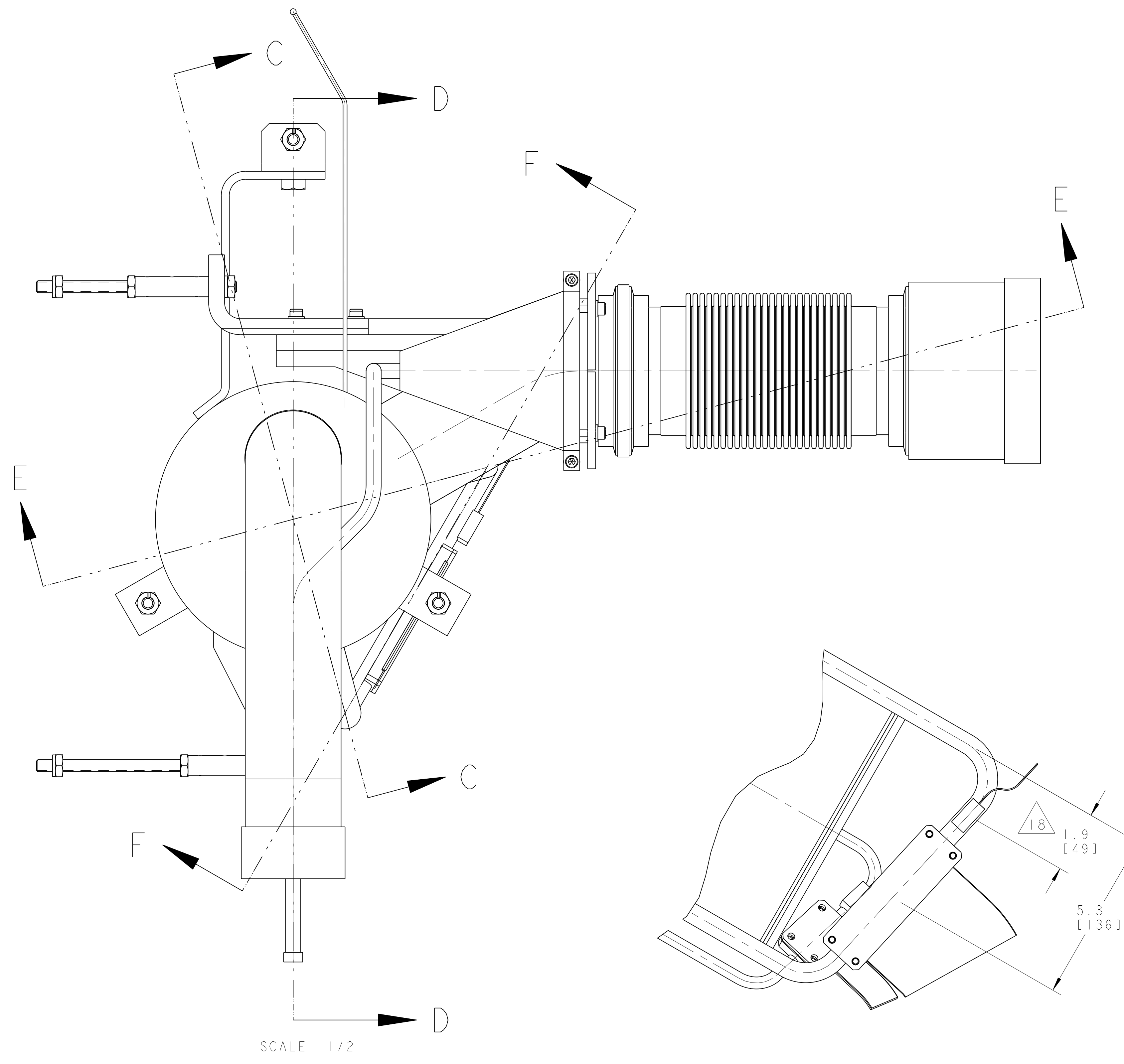
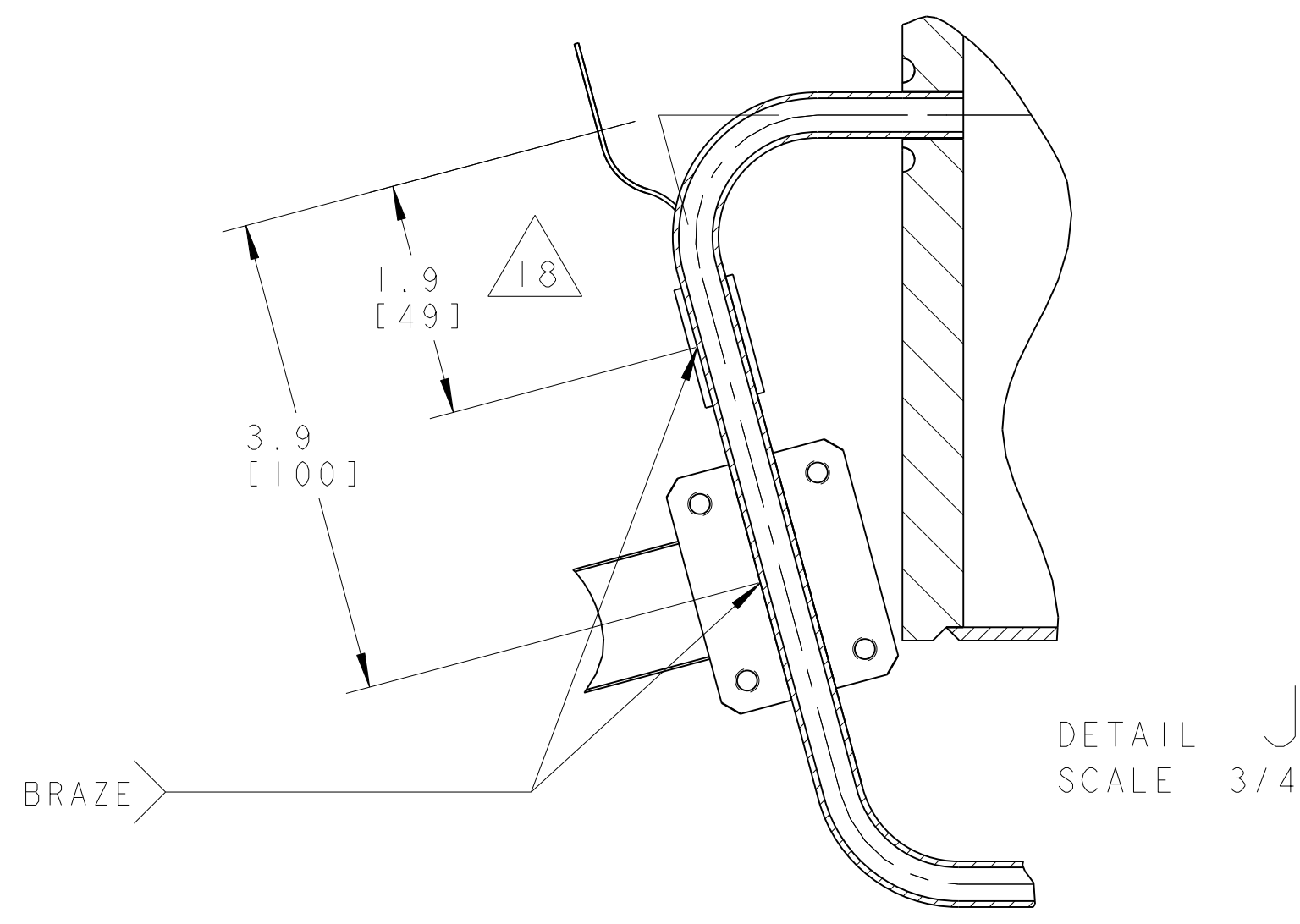

SECTION C-C  
SCALE 1/2

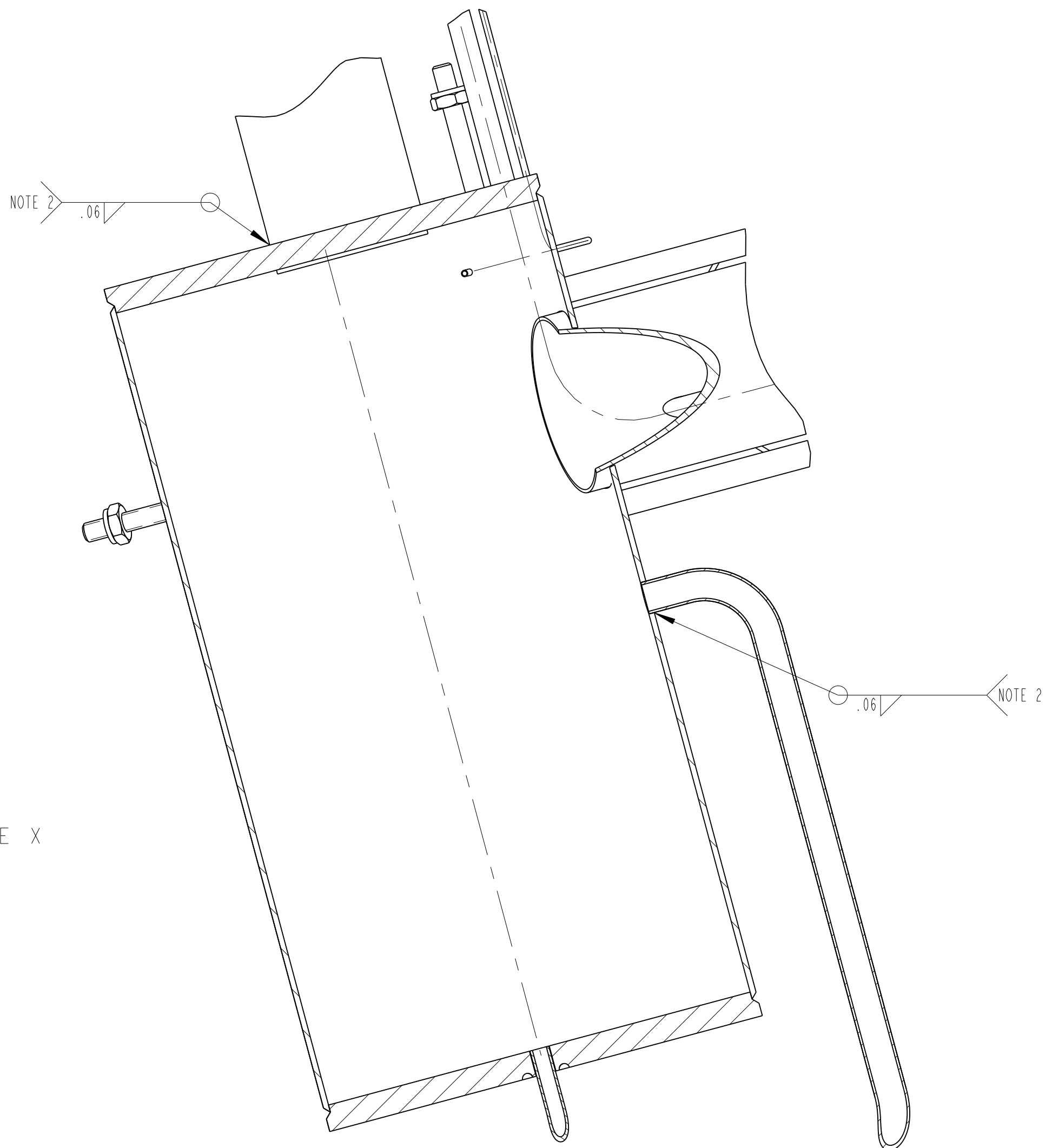

SECTION E-E  
SCALE 1/2

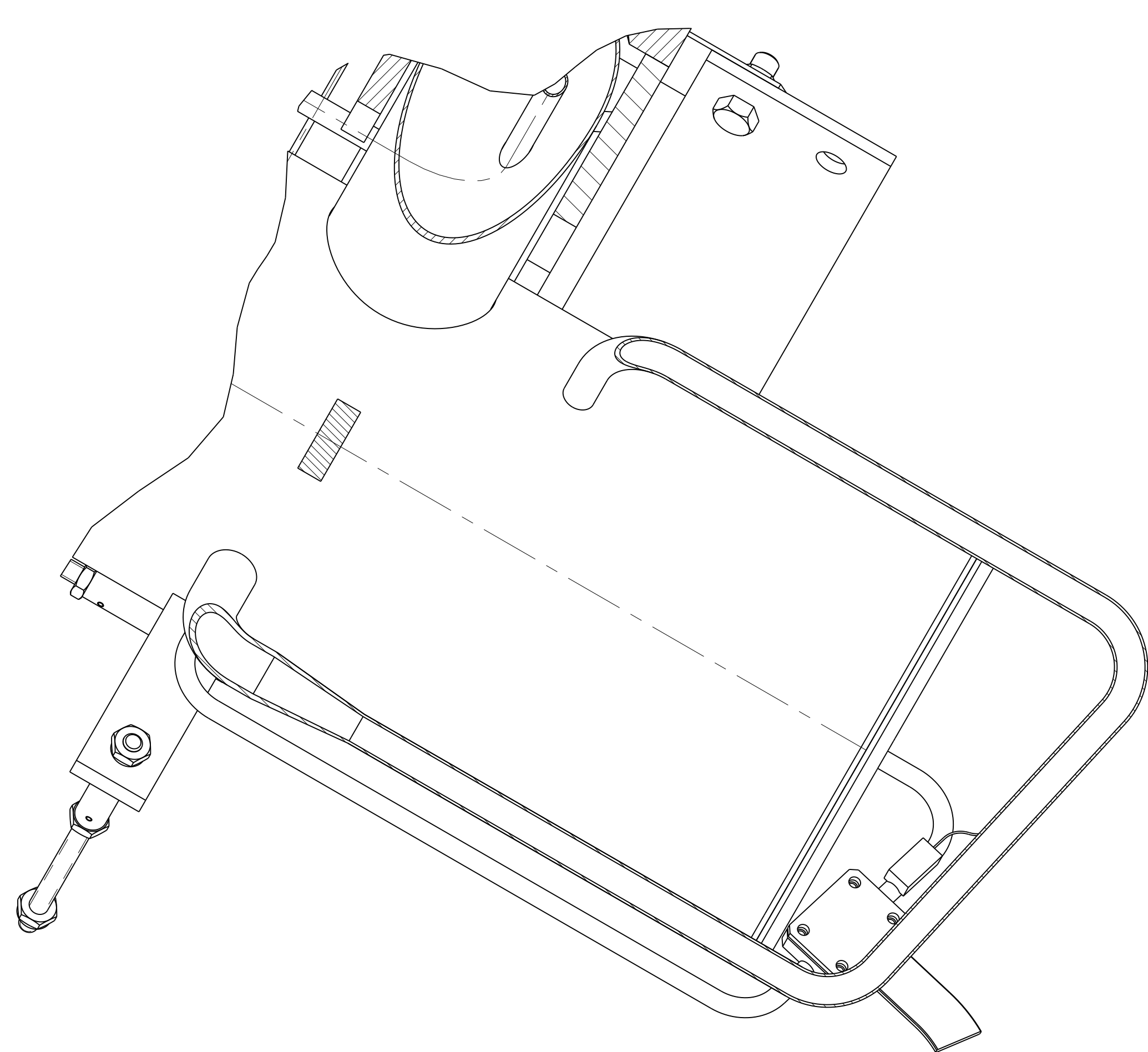

SECTION F-F  
SCALE 1/2

ERNEST ORLANDO LAWRENCE BERKELEY NATIONAL LABORATORY				UNIVERSITY OF CALIFORNIA BERKELEY	
LHC IR FEEDBOX CRYOGENICS PIPE_XB_DFBXF					
MICROFILMED:	DWG. TYPE	SHOW ON	SCALE	DO NOT CHECK PRINTS	
	ASSEM		1/4	SHEET 3 OF 3	
PATENT CLEAR:	DESIGN ACCT. NO.	CATEGORY CODE	DWG. NO.	SIZE	REV.
	Z5LCE2	LH2003	2515456	A	

NAME: ARHARRIS OBJECT: 2515456\_3 DATE: 02-Dec-02 13:50:32

2515456 A 3