



MEBT MEETING AGENDA

June 29, 2001

Mechanical Systems Update

1. **Fabrication and Procurement Update**
 - Support Frame Completed (photo) Ö
 - Raft weldments (photos, schedule)
 - Profile Monitor Beamboxes – machining progress (photos)
 - Chopper Target – two targets in shop
2. **Design Status (MEBT)**
 - Support structure calculations and lifting documentation
 - Beampipe design underway (layouts)
 - Water System design underway

Electrical Systems Update

1. **Low Level RF**
2. **Rebuncher System**
3. **Beam Diagnostics**

System Integration / Installation

1. **Raft assembly area schedule**

Upcoming Tasks and Milestones

- | | |
|--|------------|
| ◆ Profile Monitor First Article Complete | 3/31/01 |
| ◆ Raft and Support Structure Complete | 5/31/01 OR |
| ◆ Rebuncher Amplifiers #2-6 Received | 6/30/01 |
| ◆ Rebuncher Cavity #2-4 Received | 6/30/01 |
| ◆ Profile Monitor all complete | 7/31/01 |

Next Meeting : date and time to be announced



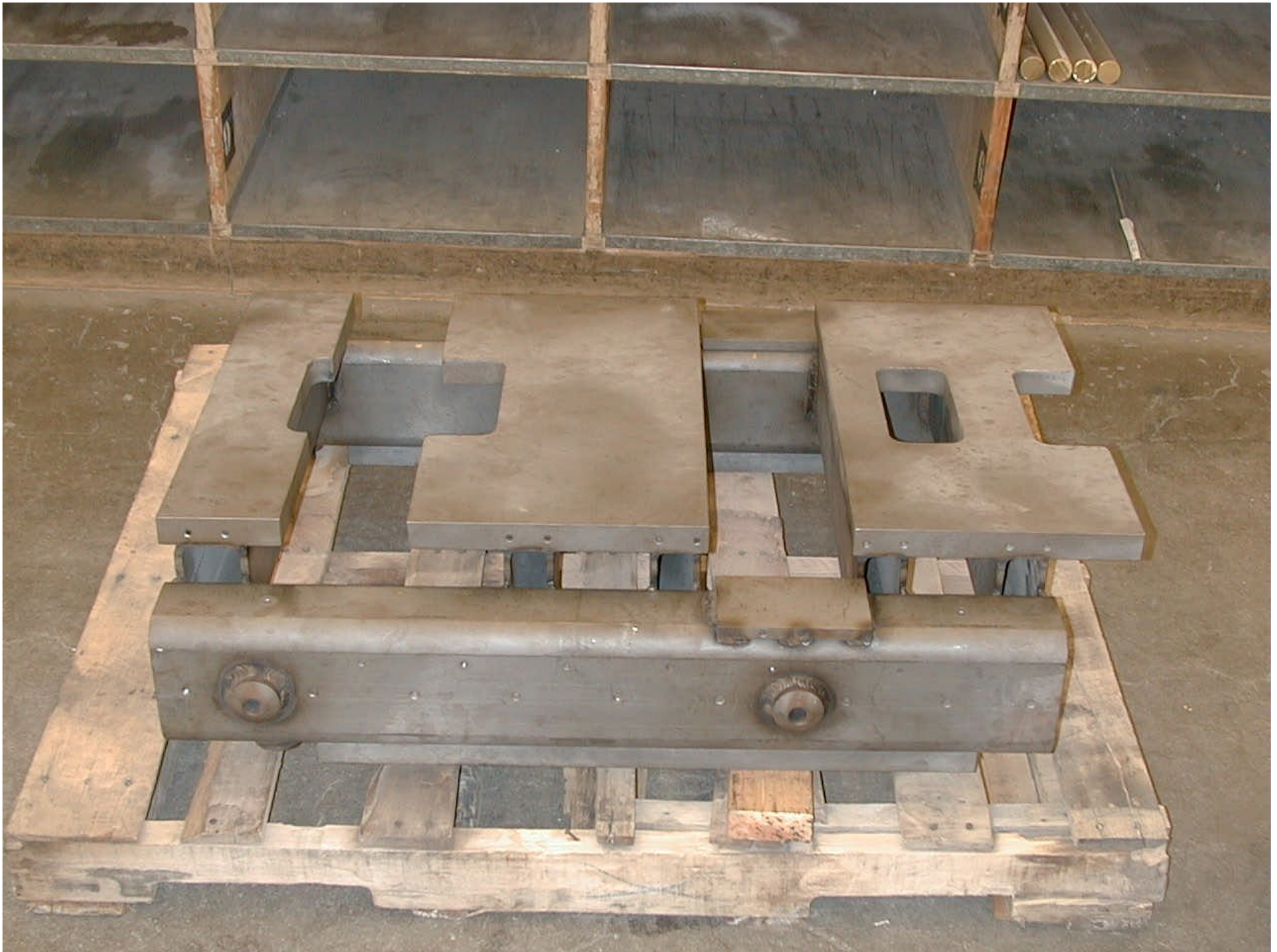



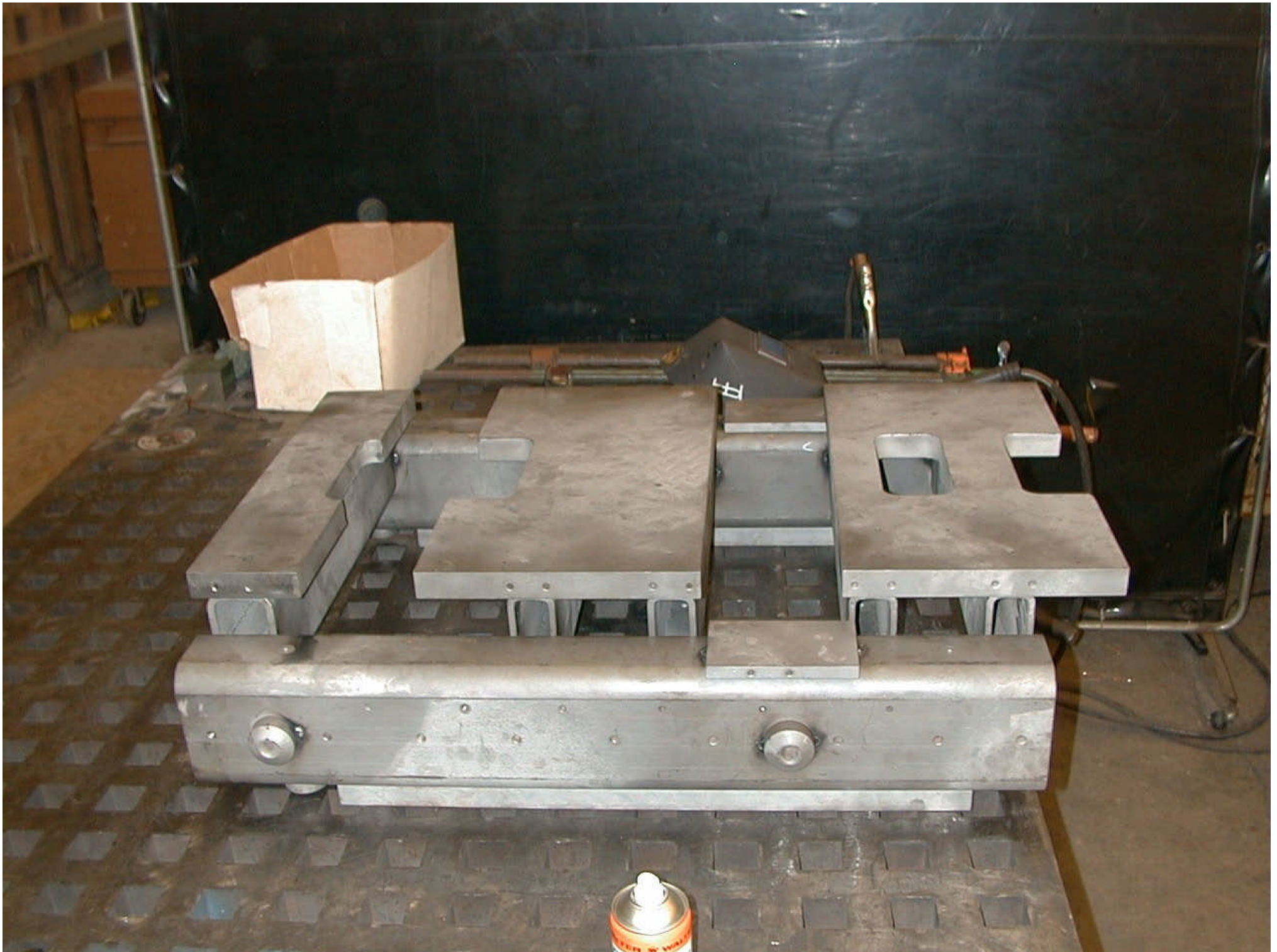

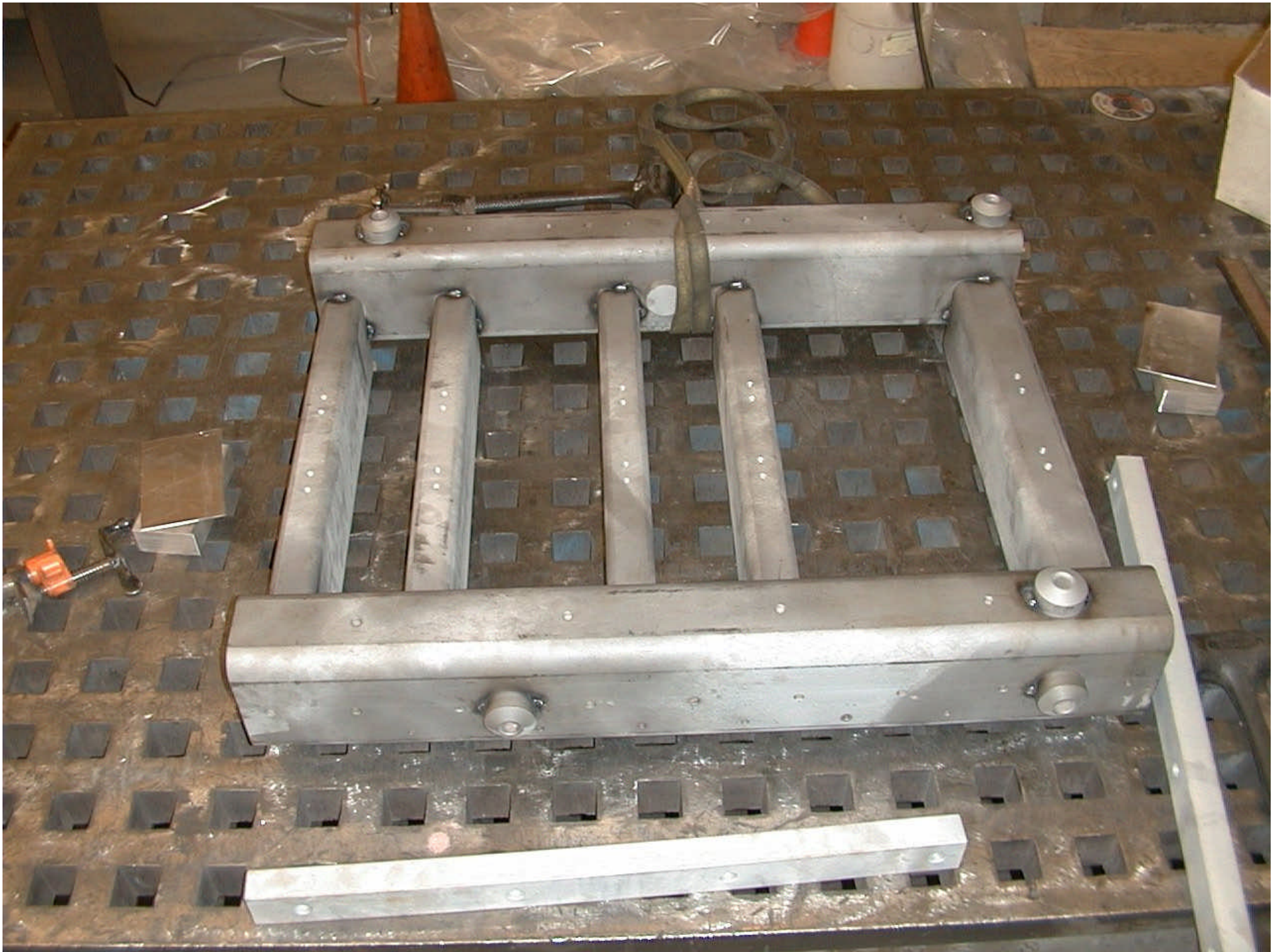

MEBT Raft #3 Schedule
June/July/August

Monday	Tuesday	Wednesday	Thursday	Friday
June 25 All parts for rafts 1, 2 and 3 are cut and preliminary machine work finished on Raft #3.	June 26 Start Raft #3 assembly and tack weld the parts together	June 27 Raft #3 is tack welded together.	June 28 Pre-weld inspection. Completely weld Raft #3.	June 29 Machine edges of Raft #3 mounting plates. Raft #3 sent off site for stress relieving. Start building raft #2.
July 2 Raft #3 sent off site for stress relieving.	July 3 Raft #3 sent off site for stress relieving.	July 4 Holiday	July 5 Raft #3 sent off site for stress relieving.	July 6 Light Sandblast of Raft #3 to remove stress relief oven scale.
July 9 Raft #3 sent off site (to L.A.) for grinding.	July 10 Raft #3 sent off site for grinding.	July 11 Raft #3 sent off site for grinding.	July 12 Raft #3 sent off site for grinding.	July 13 Raft #3 sent off site for grinding.
July 16 Raft #3 sent off site for grinding.	July 17 Raft #3 sent off site for grinding.	July 18 Inspection of the grinding of Raft #3. Clean first?	July 19 Begin machining of the top plates of raft #3	July 20 Continue machining of the top plates of raft #3.
July 23 Machine work done.	July 24 Steam clean raft #3?	July 25 Inspection of the drilled and tapped holes of Raft #3.	July 26 Inspection of the drilled and tapped holes of Raft #3.	July 27 Send Raft #3 to platers for electroless nickel plating.
July 30 Raft #3 at platers.	July 31 Raft #3 at platers.	August 1 Raft #3 at platers.	August 2 Raft #3 at platers.	August 3 Raft #3 at platers.
August 6 Raft #3 at platers.	August 7 Raft #3 returns from platers. Final inspection.	August 8 Deliver to SNS building 71	August 9	August 10





Boise Cascade
Paper Division

...erographic
R E C Y C L E D
30%
Post Consumer
Content
BLANCO / BLANC
WHITE
20 lb. 10 M
8 1/2 X 11 / GL
5000
75g/m²
P1-054901
Recycled Chlor Paper / Recycled Chlor
Paper 2

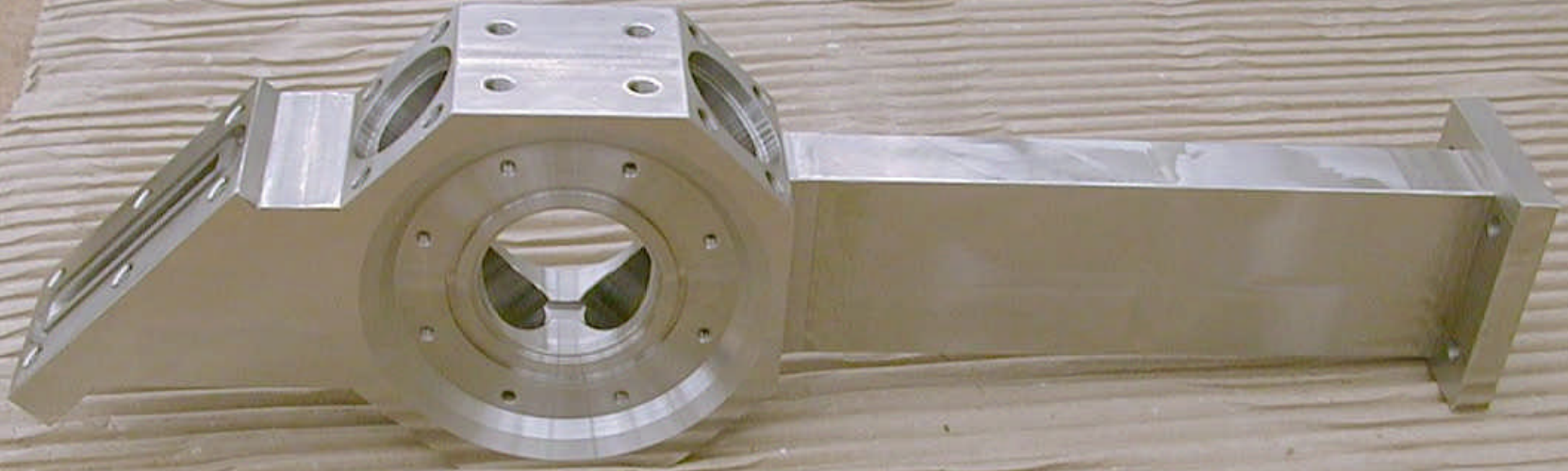

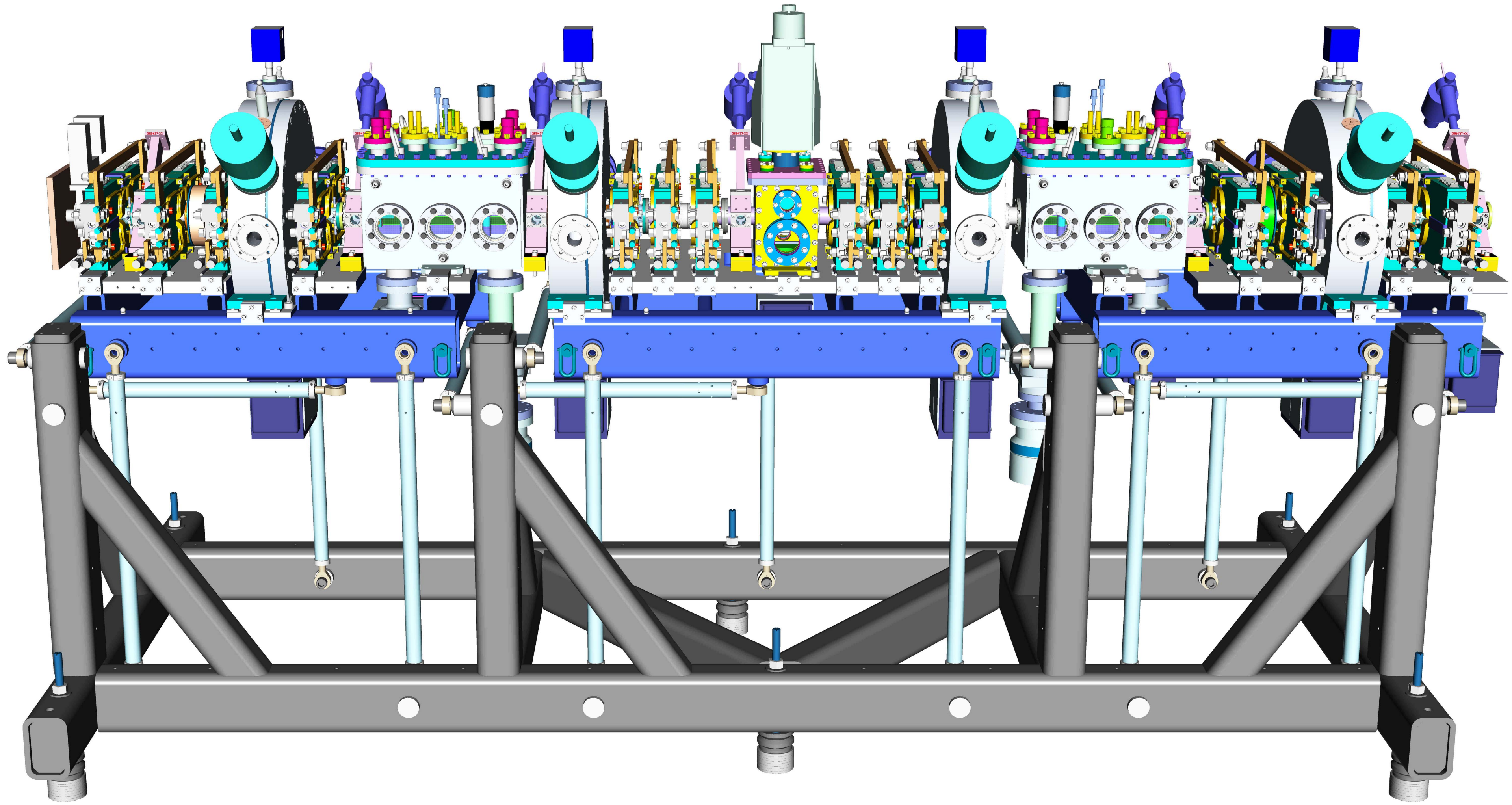

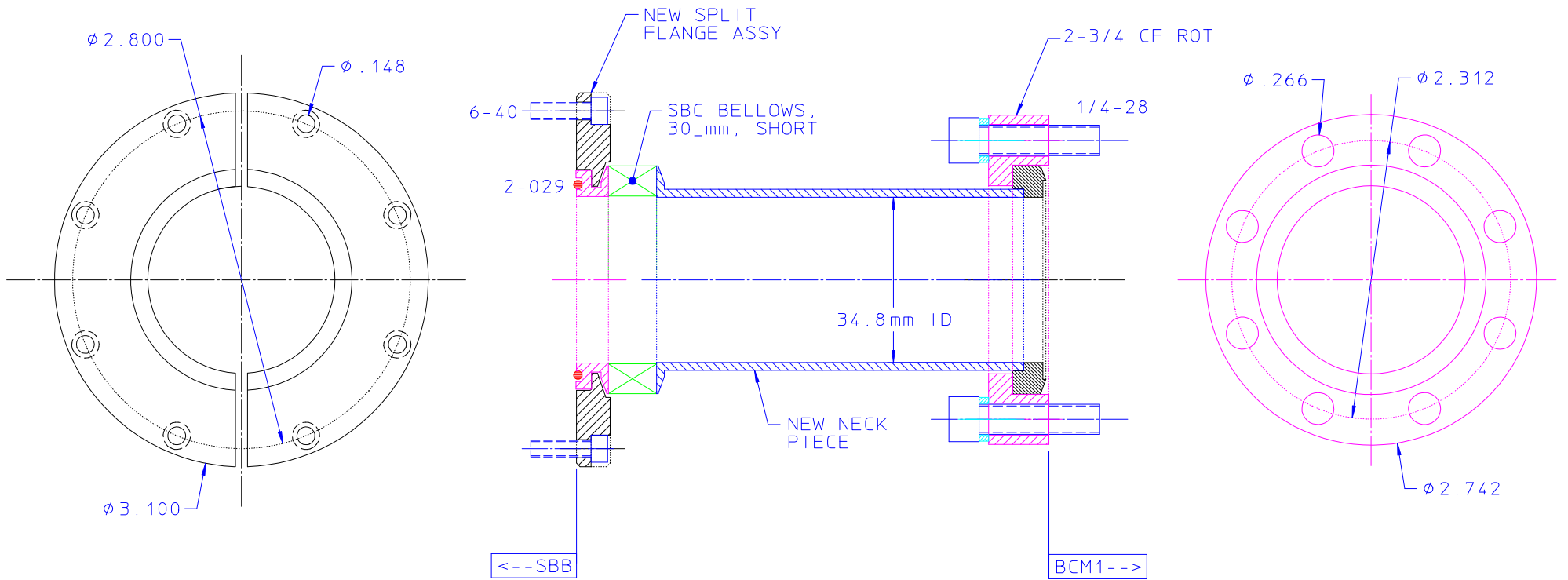

BP 1

BEAM-->

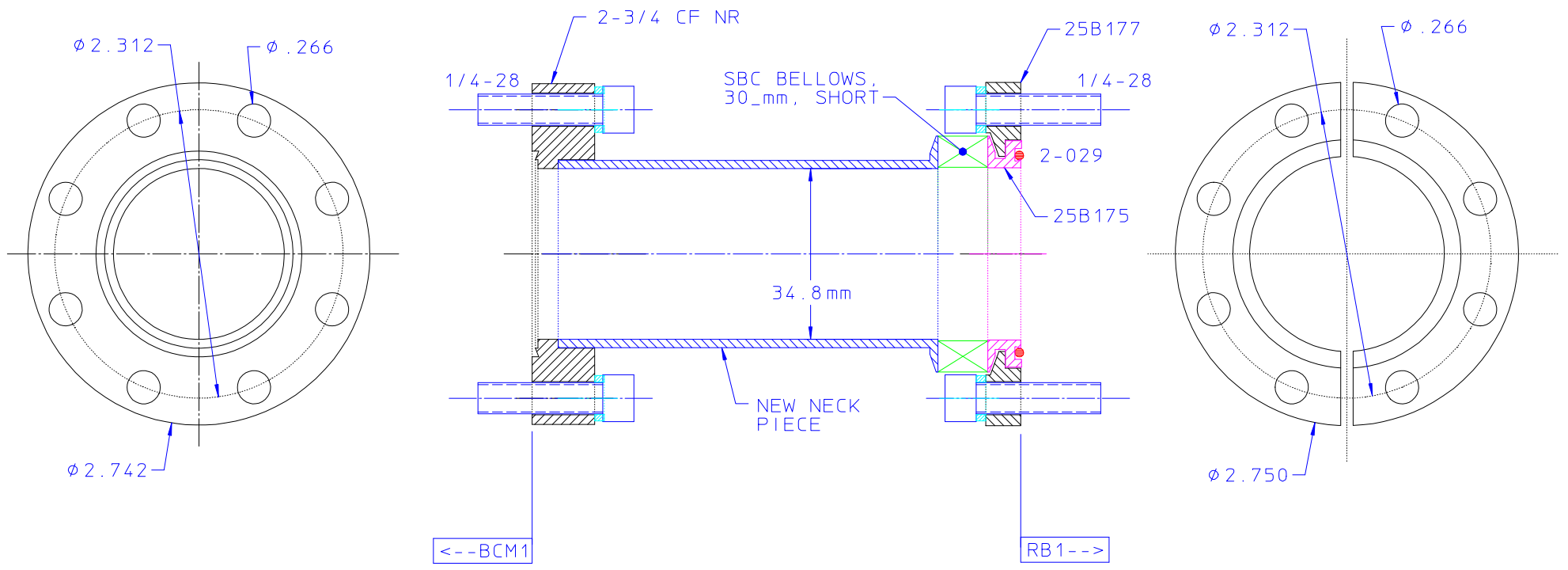

BP 2

BEAM-->

MEWASA BELLOWS
NS DN25-31/51
7 CNV (15.4 mm
FREE LENGTH)

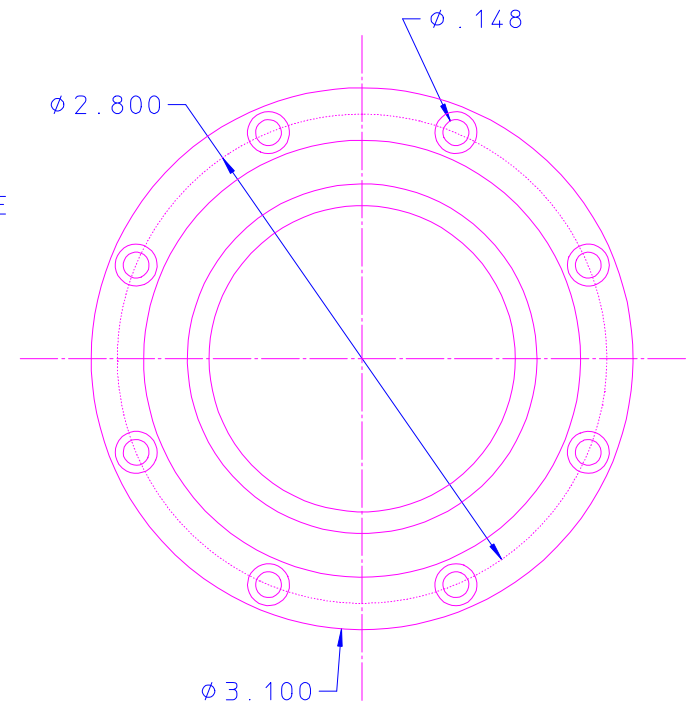
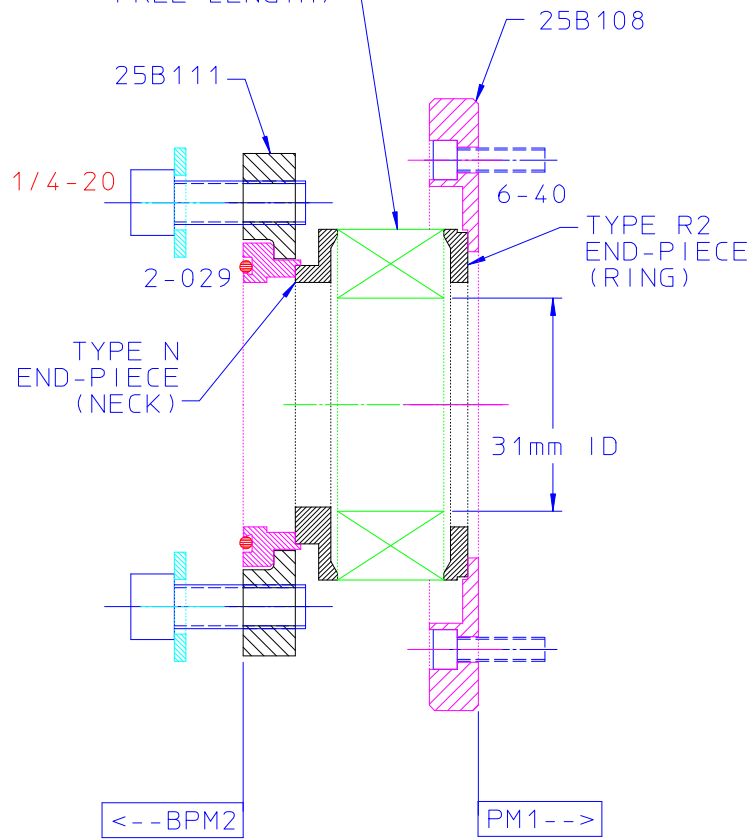

B P 3

BEAM-->

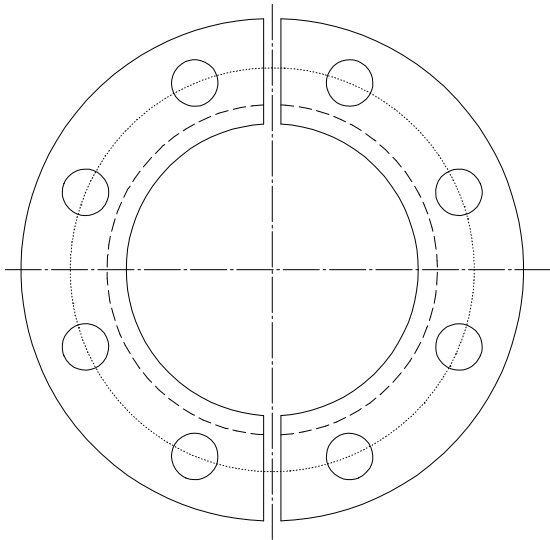

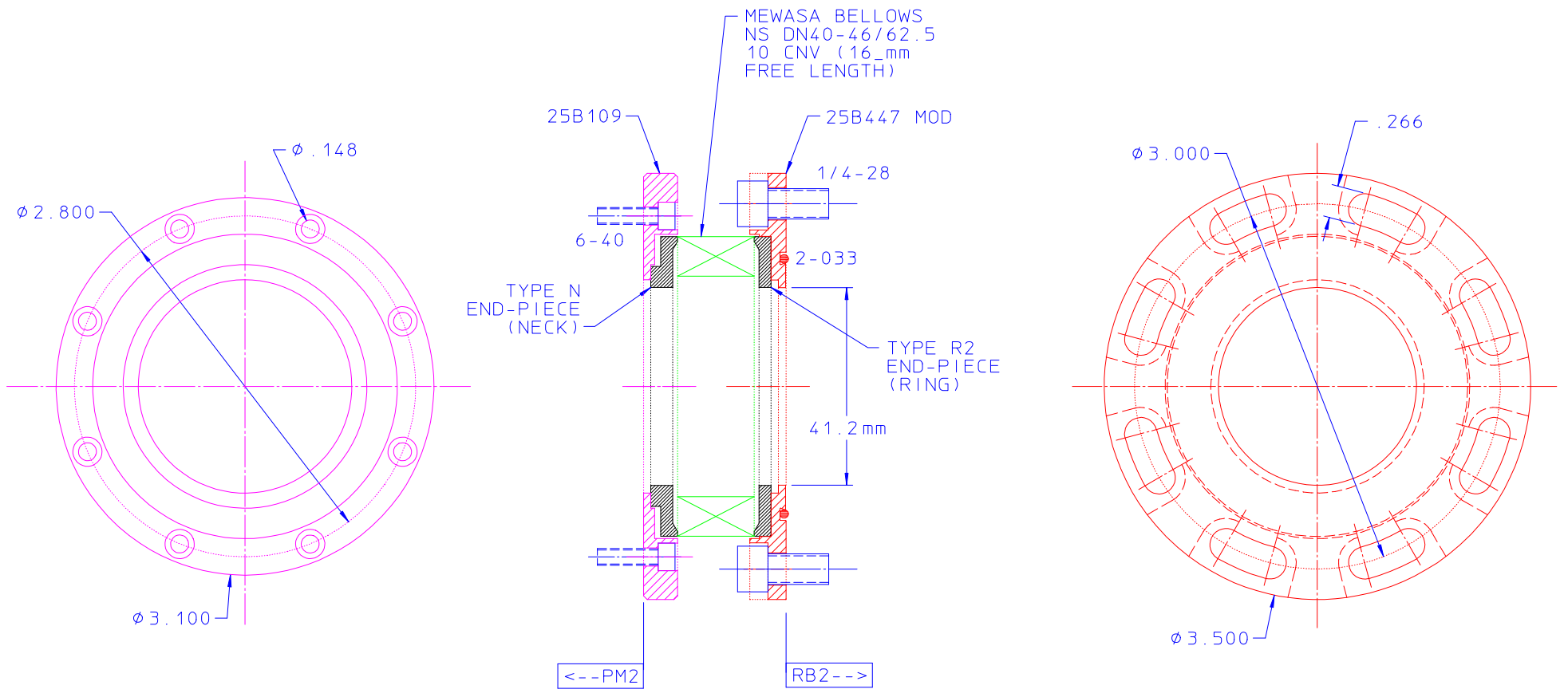

B P 4

BEAM-->

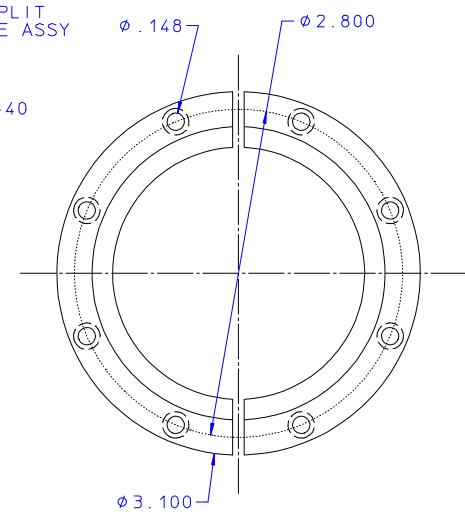
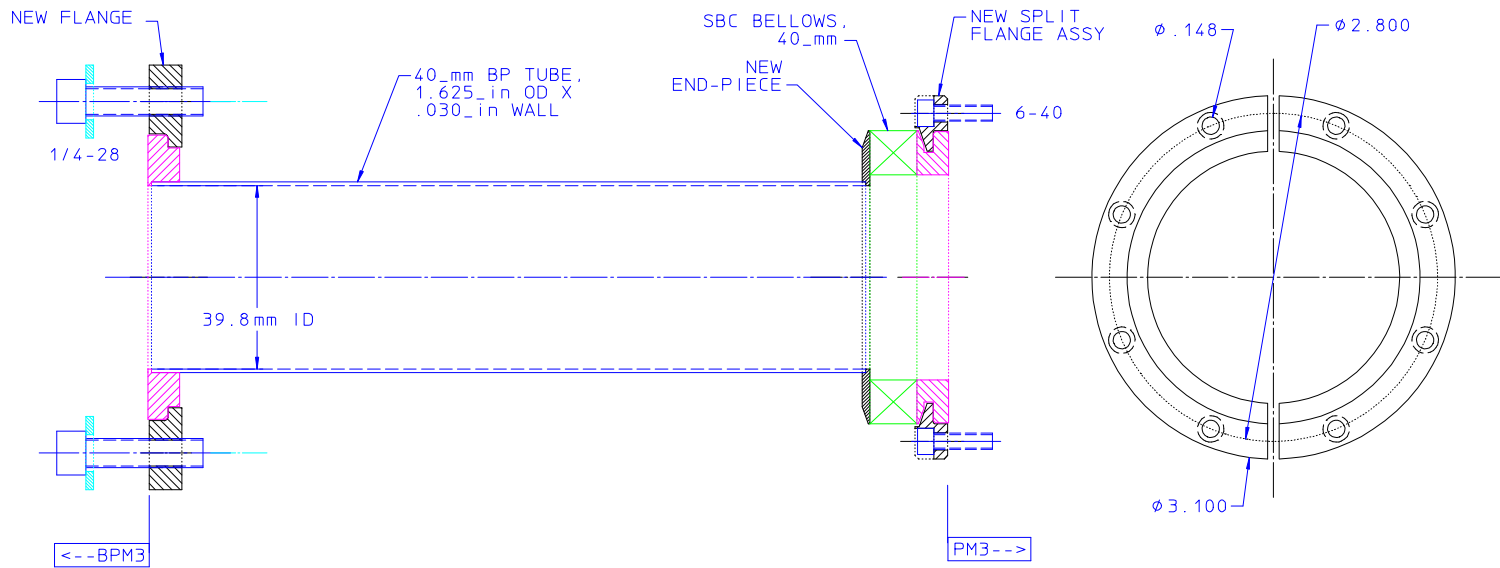
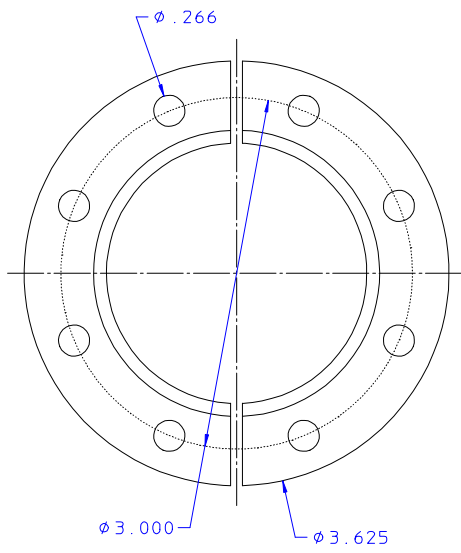

BP5

BEAM-->

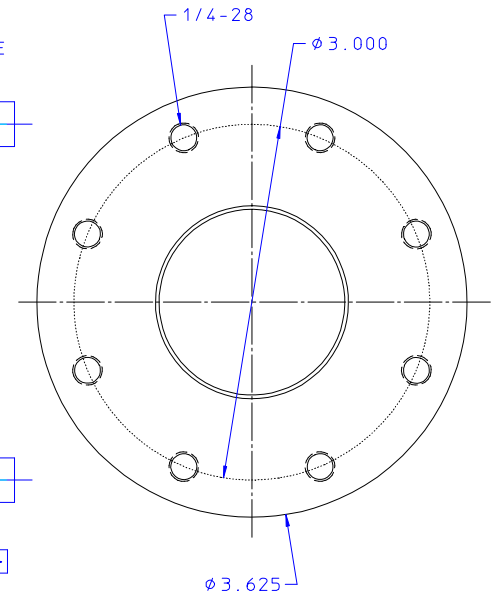
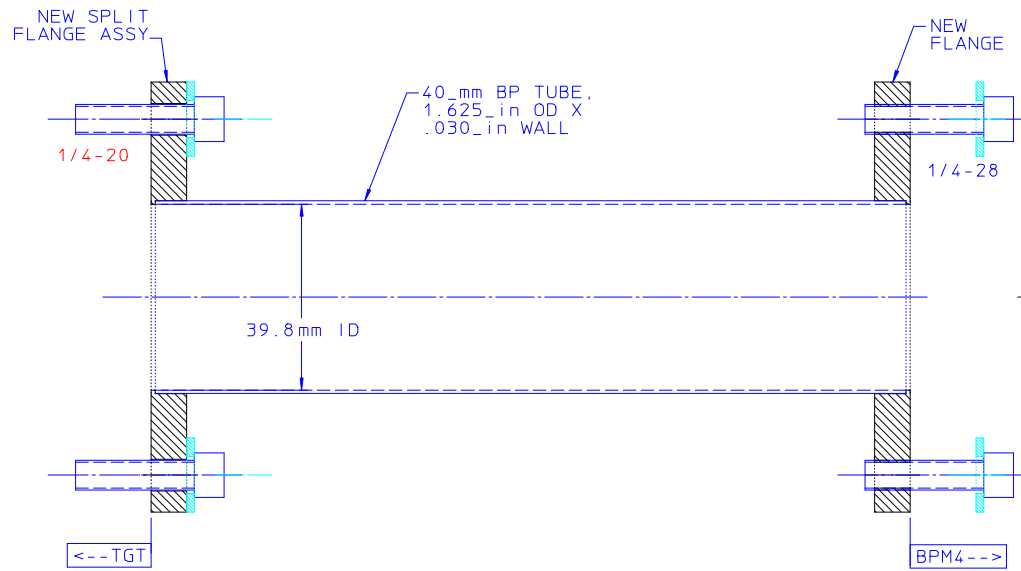
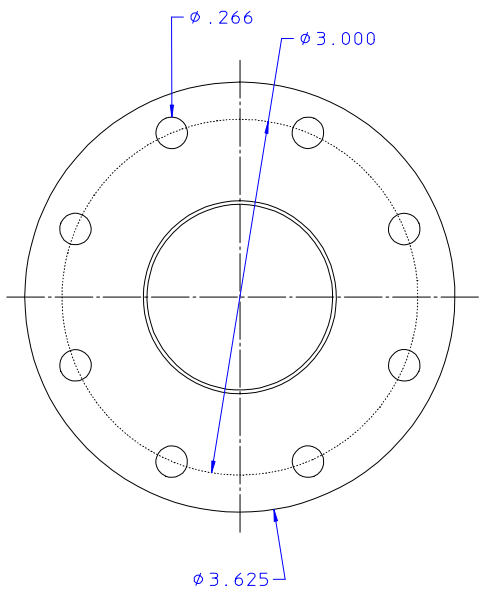

BP6

BEAM-->

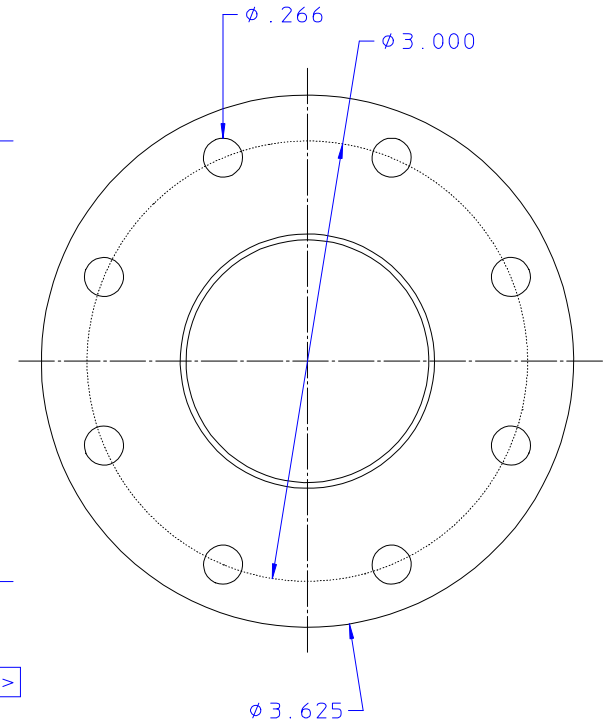
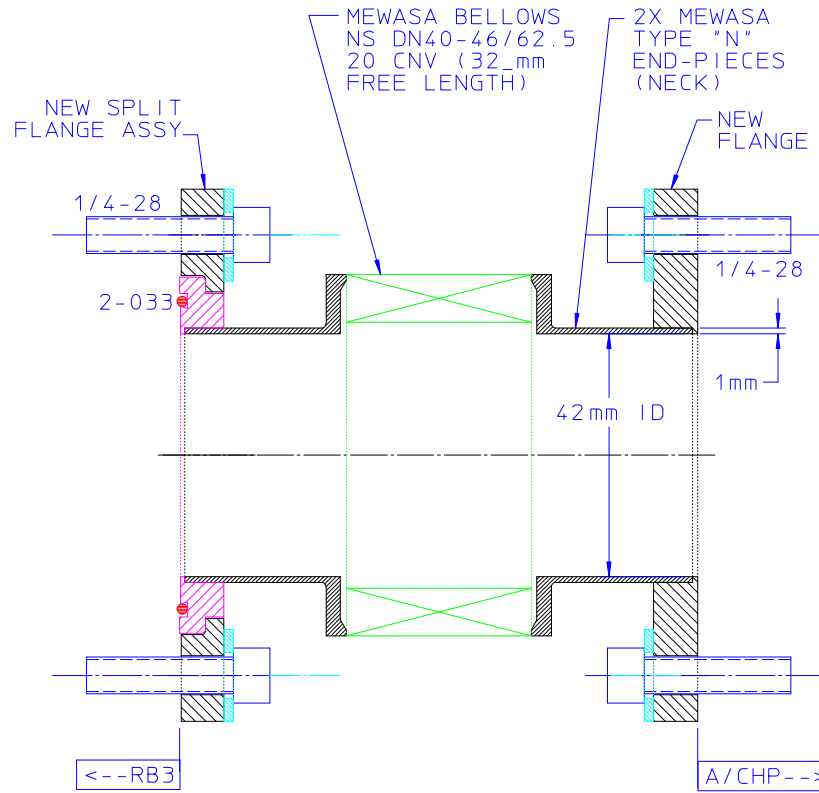
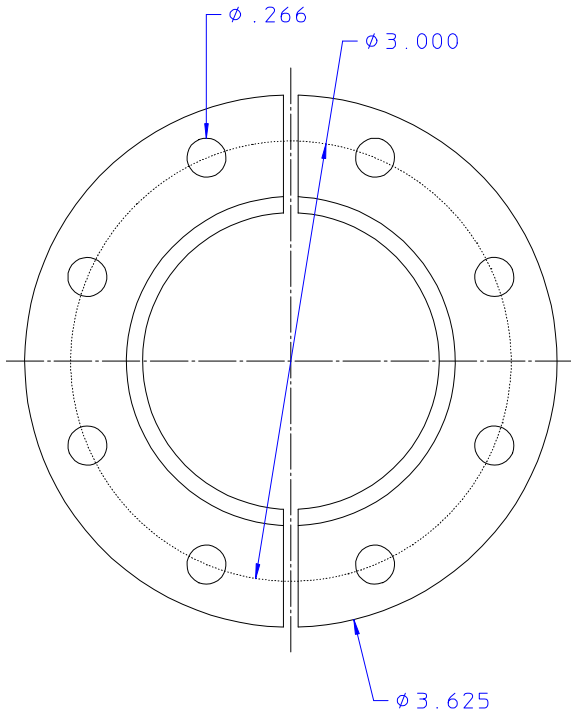

BP 7

BEAM-->

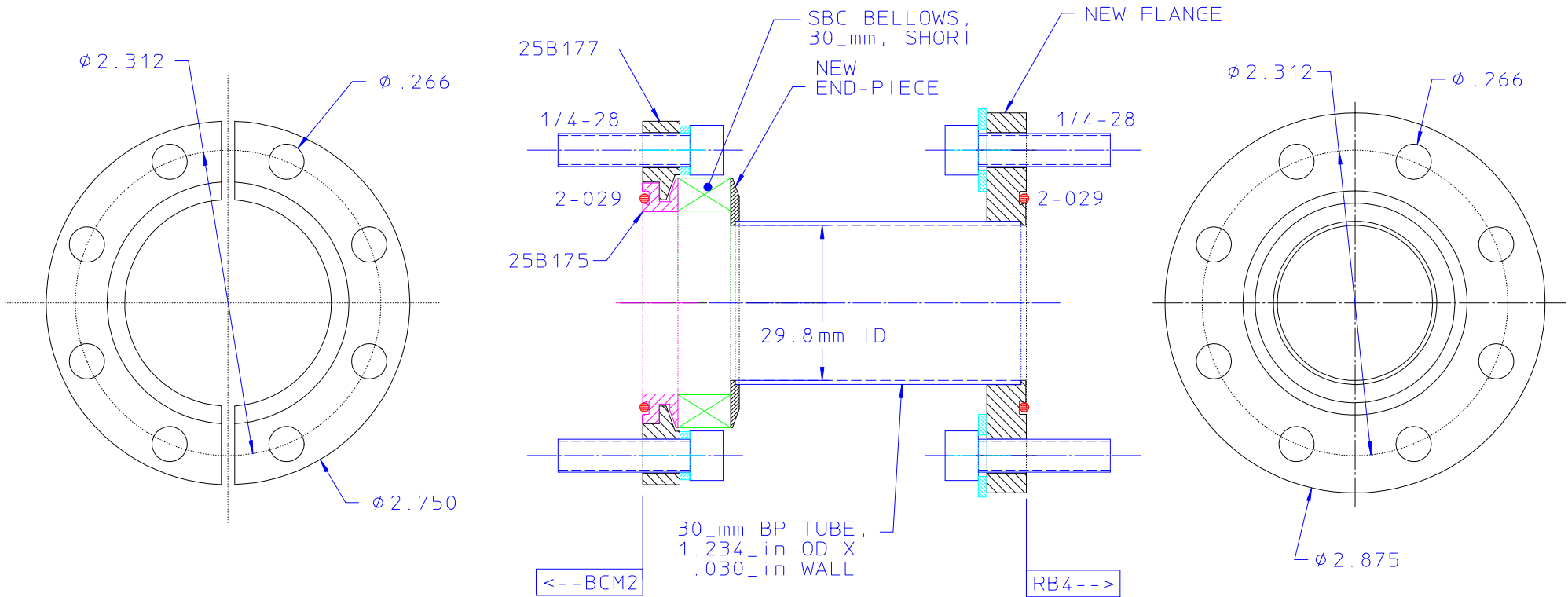

BP 8

BEAM-->

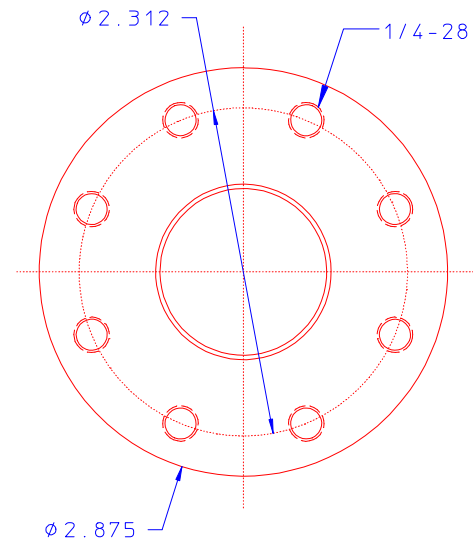
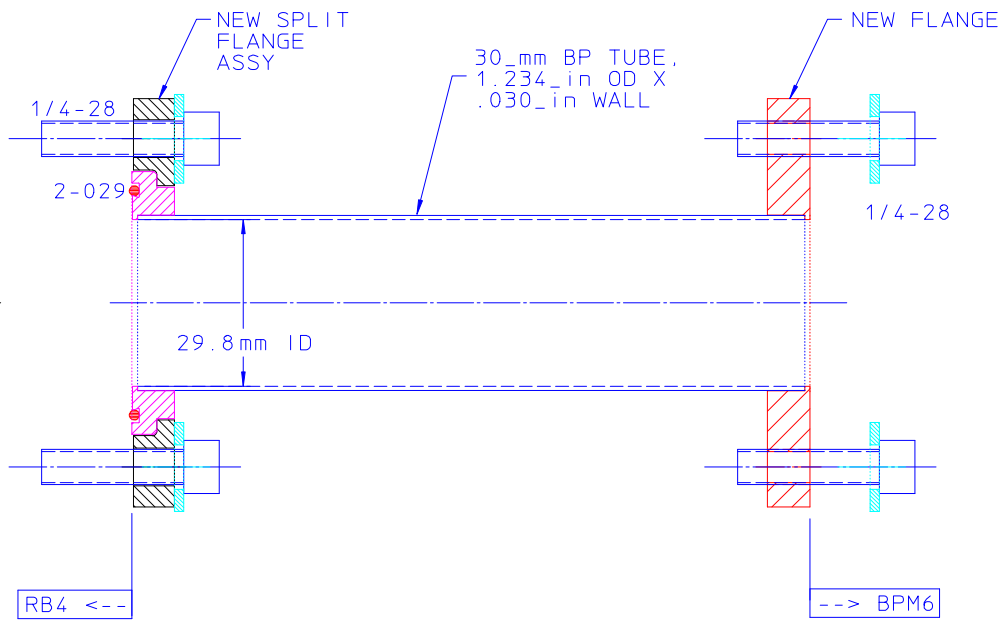
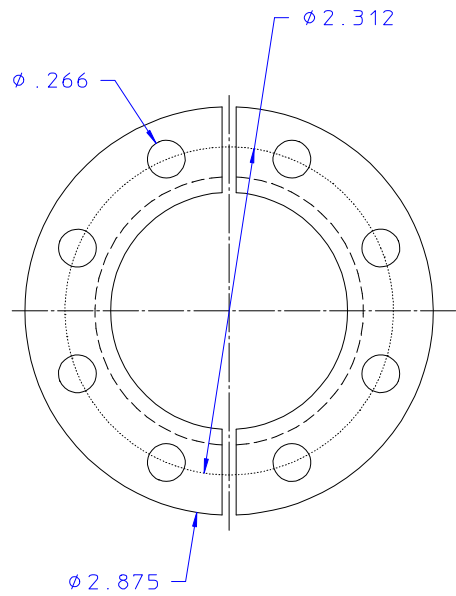

B P 9

BEAM-->