

4

3

2

1

D

D

C

C

B

B

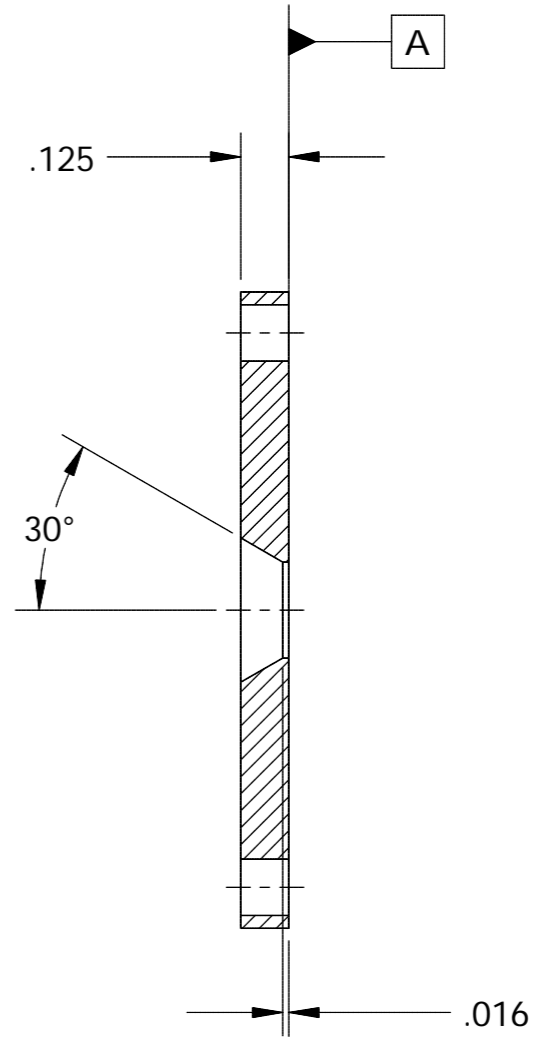
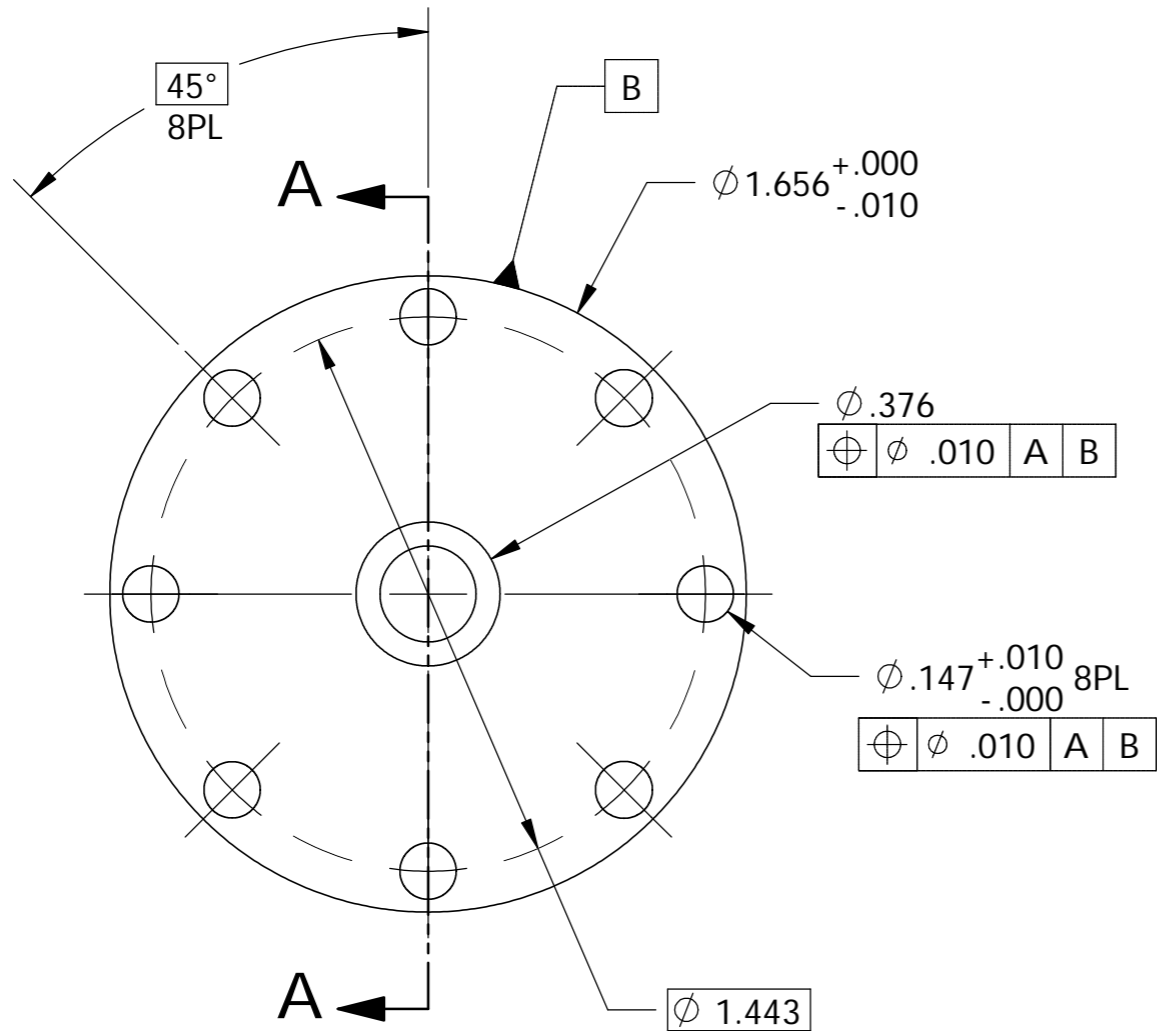

SECTION A-A

**PRELIMINARY - NOT FOR FABRICATION**

A/R			SST, 304L
REQD	ITEM	PART NO.	DESCRIPTION
PROJECT NAME:			ERNEST ORLANDO LAWRENCE BERKELEY NATIONAL LABORATORY UNIVERSITY OF CALIFORNIA
PROJECT NUMBER:			
NEXT ASSY:			27S328
CALC. WT.	KG.	0.07	LB.
DO NOT SCALE PRINT			CATEGORY CODE:
SCALE:	2:1		
THIRD ANGLE PROJECTION			
SHEET 1 OF 1			SIZE: <b>B</b>
DWG NO: 27A333			REV <b>B</b>

REV	DRAWN BY	APPVD.	DATE	DESCRIPTION
B	PAL	R. KELLER	12/15/03	MATERIAL MODIFIED.
A	PAL	R. KELLER	11/25/03	INITIAL RELEASE

UNLESS OTHERWISE SPECIFIED

TOLERANCES:  
 X ±.1\_INCH .XX ±.01\_INCH .XXX ±.005\_INCH  
 FRACTIONS: -/--  
 ANGLES: 0.1° / INCH  
 MACH. SURFS.: 125 MICRO-INCH  OR BETTER

DO NOT SCALE DRAWING.  
 INTERPRET PER ASME Y14.5M-1994.  
 THREADS ARE CLASS 2.  
 BREAK MACHINED EDGES .016 MAX.  
 REMOVE BURRS, WELD SPLATTER &  
 LOOSE SCALE.

A

A

4

3

2