

REVISIONS				
ZONE	REV.	DESCRIPTION	DATE	APPROVED

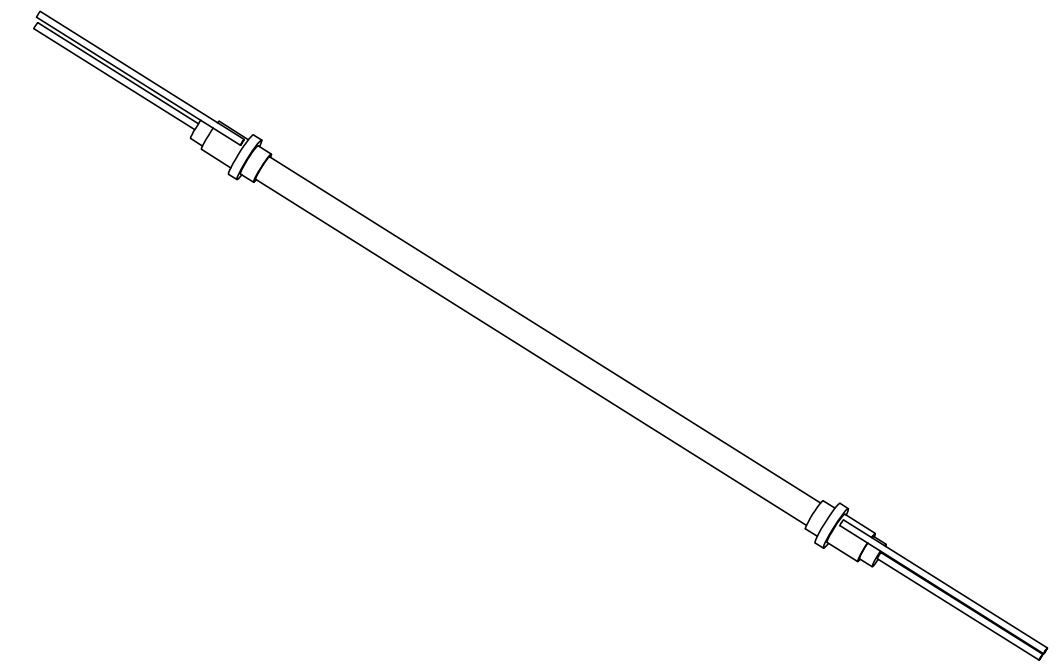
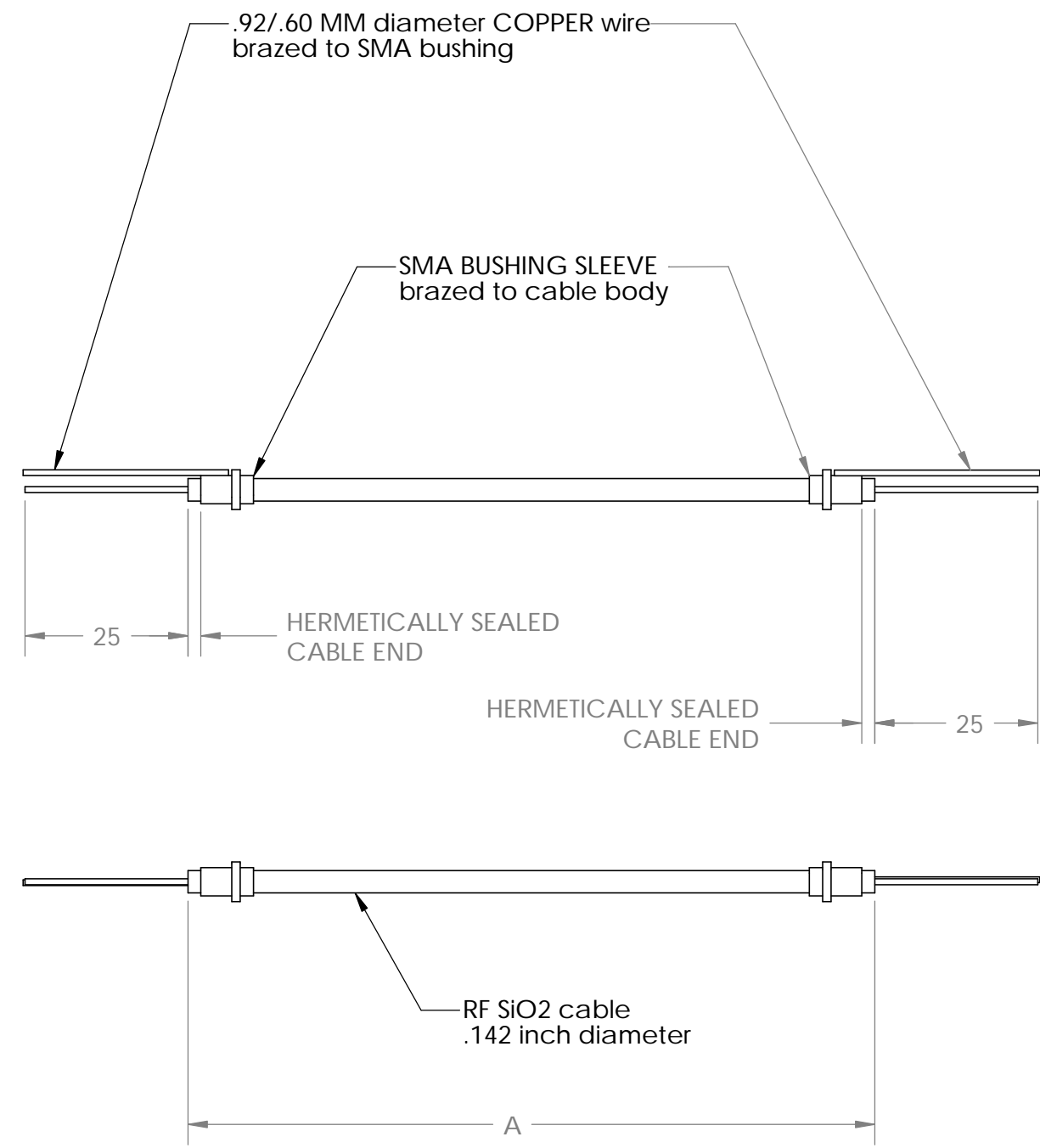

DIMENSIONS ARE IN MM

- ITEM 1 A = 107 MM
- ITEM 2 A = 113 MM
- ITEM 3 A = 121 MM
- ITEM 4 A = 130 MM
- ITEM 5 A = 167 MM

**PROPRIETARY AND CONFIDENTIAL**  
 THE INFORMATION CONTAINED IN THIS DRAWING IS THE SOLE PROPERTY OF <INSERT COMPANY NAME HERE>. ANY REPRODUCTION IN PART OR AS A WHOLE WITHOUT THE WRITTEN PERMISSION OF <INSERT COMPANY NAME HERE> IS PROHIBITED.

UNLESS OTHERWISE SPECIFIED:		NAME	DATE	LAWRENCE BERKELEY NATIONAL LABORATORY UNIVERSITY OF CALIFORNIA-BERKELEY
DIMENSIONS ARE IN INCHES TOLERANCES: FRACTIONAL ± ANGULAR: MACH ± BEND ± TWO PLACE DECIMAL ± THREE PLACE DECIMAL ±		DRAWN	Matt Hoff 06-27-03	
INTERPRET GEOMETRIC TOLERANCING PER:		CHECKED		TITLE: LHC - TURNER GAS DETECTOR HOUSING RAD HARD WIRE ASSEMBLY
MATERIAL		ENG APPR.		
FINISH		MFG APPR.		
NEXT ASSY	USED ON	Q.A.		SIZE DWG. NO. REV
APPLICATION		COMMENTS:		<b>B</b> 2504232
DO NOT SCALE DRAWING				SCALE: 1:1 SHEET 1 OF 1

D  
C  
B  
A

D  
C  
B  
A