

D

C

B

A

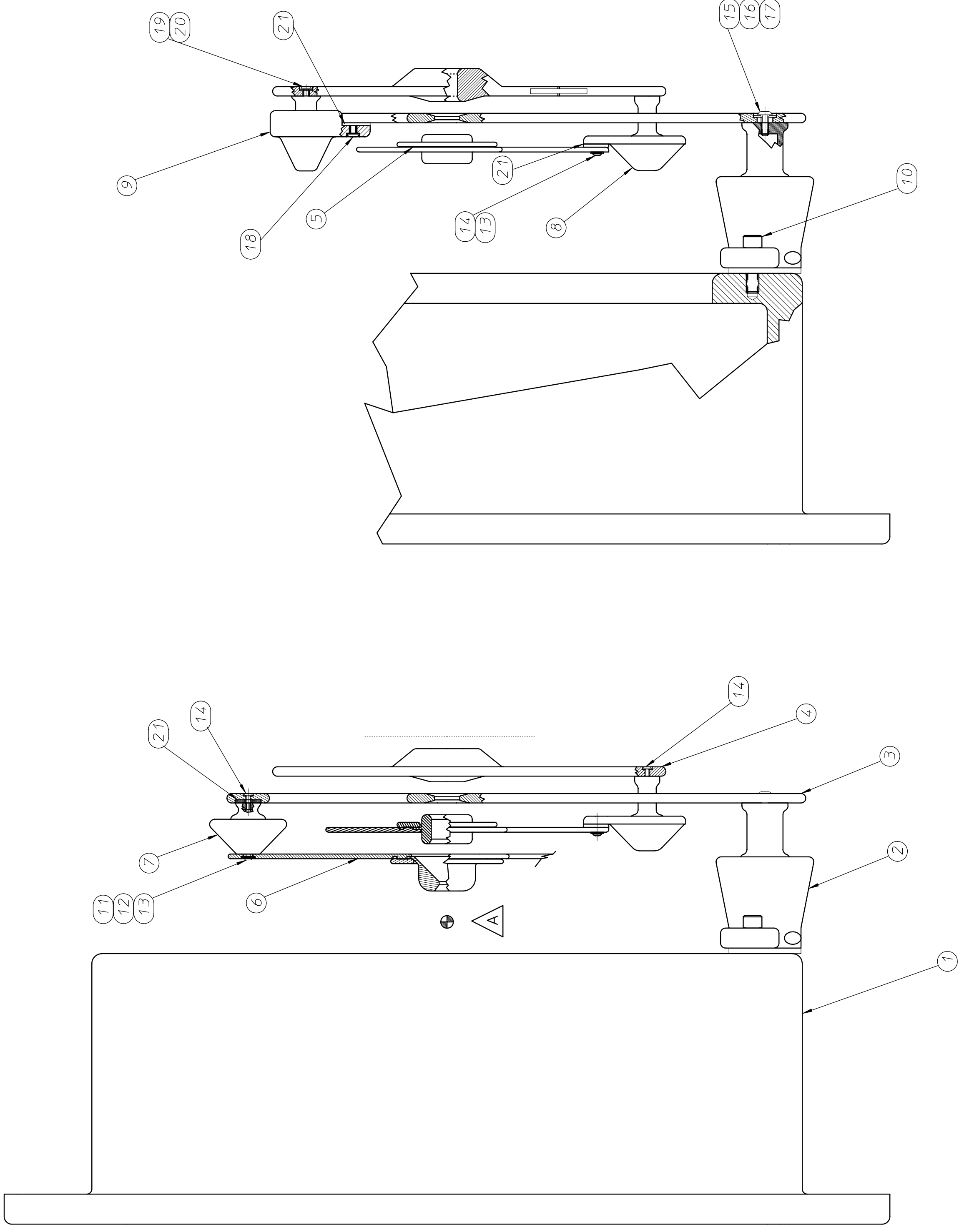
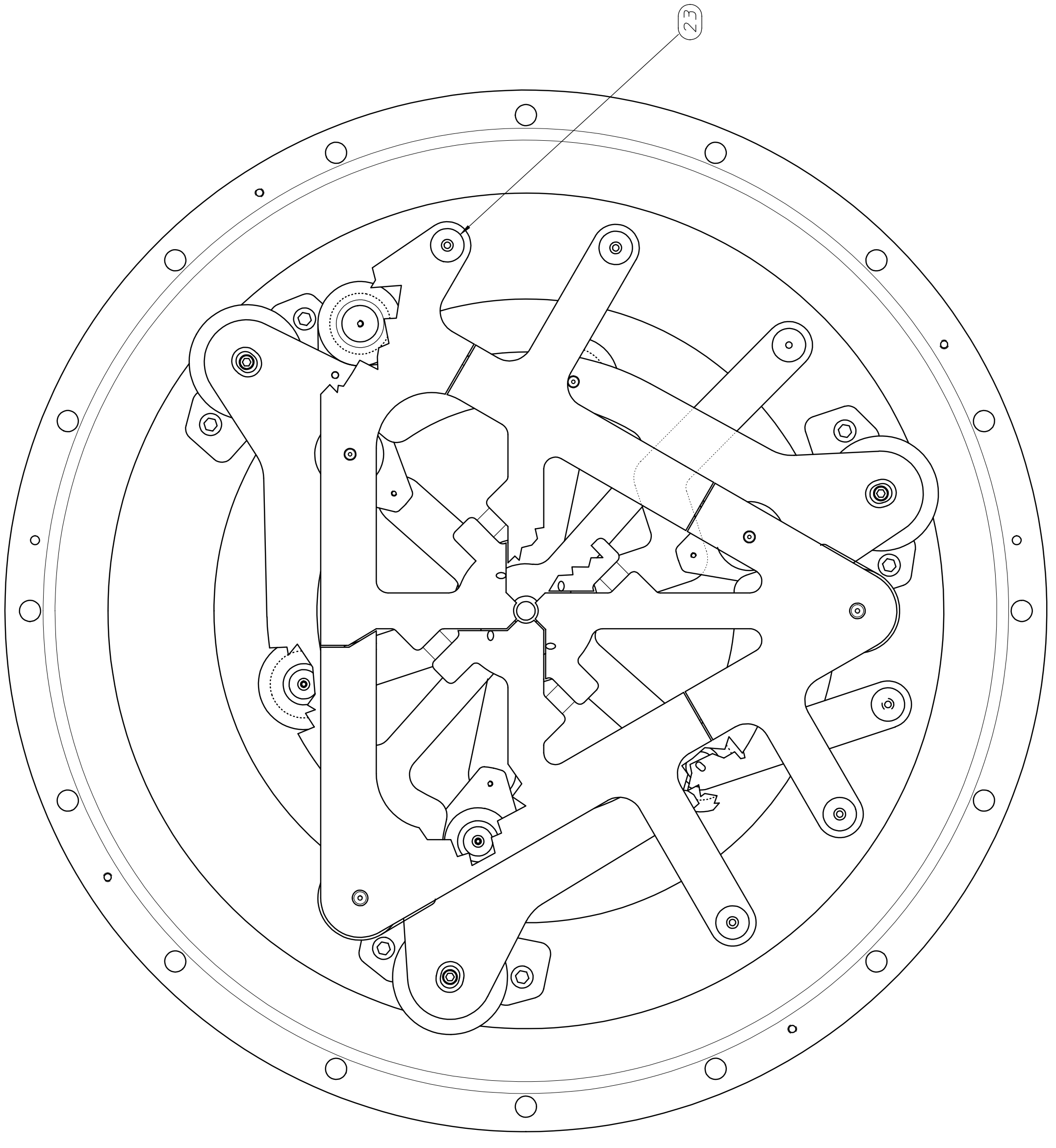

4	23	2167313	ELECTRODE HIGH-VOLTAGE CONNECT
A/R	22	--	SHIM, STAINLESS STEEL, NOM .158 THK
A/R	21	--	SHIM, STAINLESS STEEL, NOM .08 THK
3	20	--	WASHER, STAINLESS STEEL, #6
3	19	--	WASHER, STAINLESS STEEL, #6
3	18	--	WASHER, STAINLESS STEEL, #6
3	17	2167301	BUTTON HEAD CAP SCREW, STAINLESS STEEL, #4-32, LG. VENTED
3	16	--	WASHER, STAINLESS STEEL, #10
3	15	--	WASHER, STAINLESS STEEL, #10
3	14	--	WASHER, STAINLESS STEEL, #10
3	13	--	WASHER, STAINLESS STEEL, #10
3	12	--	WASHER, STAINLESS STEEL, #10
3	11	--	WASHER, STAINLESS STEEL, #10
3	10	--	WASHER, STAINLESS STEEL, #10
3	9	--	WASHER, STAINLESS STEEL, #10
3	8	--	WASHER, STAINLESS STEEL, #10
3	7	--	WASHER, STAINLESS STEEL, #10
3	6	--	WASHER, STAINLESS STEEL, #10
3	5	--	WASHER, STAINLESS STEEL, #10
3	4	--	WASHER, STAINLESS STEEL, #10
3	3	--	WASHER, STAINLESS STEEL, #10
3	2	--	WASHER, STAINLESS STEEL, #10
3	1	--	WASHER, STAINLESS STEEL, #10

UNLESS OTHERWISE SPECIFIED	SHIP	NO	NO
FINISH	AS-BUILT	AS-BUILT	AS-BUILT
TEMPERATURE	AS-BUILT	AS-BUILT	AS-BUILT
STRESS	AS-BUILT	AS-BUILT	AS-BUILT
WELDING	AS-BUILT	AS-BUILT	AS-BUILT
THREADS	AS-BUILT	AS-BUILT	AS-BUILT
PLATING	AS-BUILT	AS-BUILT	AS-BUILT
COATING	AS-BUILT	AS-BUILT	AS-BUILT
PAINT	AS-BUILT	AS-BUILT	AS-BUILT
WARRANTY	AS-BUILT	AS-BUILT	AS-BUILT
REVISIONS	AS-BUILT	AS-BUILT	AS-BUILT
DATE	AS-BUILT	AS-BUILT	AS-BUILT
BY	AS-BUILT	AS-BUILT	AS-BUILT
CHECKED	AS-BUILT	AS-BUILT	AS-BUILT
APPROVED	AS-BUILT	AS-BUILT	AS-BUILT
DATE	AS-BUILT	AS-BUILT	AS-BUILT
BY	AS-BUILT	AS-BUILT	AS-BUILT
CHECKED	AS-BUILT	AS-BUILT	AS-BUILT
APPROVED	AS-BUILT	AS-BUILT	AS-BUILT
DATE	AS-BUILT	AS-BUILT	AS-BUILT
BY	AS-BUILT	AS-BUILT	AS-BUILT

UNLESS OTHERWISE SPECIFIED	SHIP	NO	NO
FINISH	AS-BUILT	AS-BUILT	AS-BUILT
TEMPERATURE	AS-BUILT	AS-BUILT	AS-BUILT
STRESS	AS-BUILT	AS-BUILT	AS-BUILT
WELDING	AS-BUILT	AS-BUILT	AS-BUILT
THREADS	AS-BUILT	AS-BUILT	AS-BUILT
PLATING	AS-BUILT	AS-BUILT	AS-BUILT
COATING	AS-BUILT	AS-BUILT	AS-BUILT
PAINT	AS-BUILT	AS-BUILT	AS-BUILT
WARRANTY	AS-BUILT	AS-BUILT	AS-BUILT
REVISIONS	AS-BUILT	AS-BUILT	AS-BUILT
DATE	AS-BUILT	AS-BUILT	AS-BUILT
BY	AS-BUILT	AS-BUILT	AS-BUILT
CHECKED	AS-BUILT	AS-BUILT	AS-BUILT
APPROVED	AS-BUILT	AS-BUILT	AS-BUILT
DATE	AS-BUILT	AS-BUILT	AS-BUILT
BY	AS-BUILT	AS-BUILT	AS-BUILT

UNLESS OTHERWISE SPECIFIED	SHIP	NO	NO
FINISH	AS-BUILT	AS-BUILT	AS-BUILT
TEMPERATURE	AS-BUILT	AS-BUILT	AS-BUILT
STRESS	AS-BUILT	AS-BUILT	AS-BUILT
WELDING	AS-BUILT	AS-BUILT	AS-BUILT
THREADS	AS-BUILT	AS-BUILT	AS-BUILT
PLATING	AS-BUILT	AS-BUILT	AS-BUILT
COATING	AS-BUILT	AS-BUILT	AS-BUILT
PAINT	AS-BUILT	AS-BUILT	AS-BUILT
WARRANTY	AS-BUILT	AS-BUILT	AS-BUILT
REVISIONS	AS-BUILT	AS-BUILT	AS-BUILT
DATE	AS-BUILT	AS-BUILT	AS-BUILT
BY	AS-BUILT	AS-BUILT	AS-BUILT
CHECKED	AS-BUILT	AS-BUILT	AS-BUILT
APPROVED	AS-BUILT	AS-BUILT	AS-BUILT
DATE	AS-BUILT	AS-BUILT	AS-BUILT
BY	AS-BUILT	AS-BUILT	AS-BUILT

UNLESS OTHERWISE SPECIFIED	SHIP	NO	NO
FINISH	AS-BUILT	AS-BUILT	AS-BUILT
TEMPERATURE	AS-BUILT	AS-BUILT	AS-BUILT
STRESS	AS-BUILT	AS-BUILT	AS-BUILT
WELDING	AS-BUILT	AS-BUILT	AS-BUILT
THREADS	AS-BUILT	AS-BUILT	AS-BUILT
PLATING	AS-BUILT	AS-BUILT	AS-BUILT
COATING	AS-BUILT	AS-BUILT	AS-BUILT
PAINT	AS-BUILT	AS-BUILT	AS-BUILT
WARRANTY	AS-BUILT	AS-BUILT	AS-BUILT
REVISIONS	AS-BUILT	AS-BUILT	AS-BUILT
DATE	AS-BUILT	AS-BUILT	AS-BUILT
BY	AS-BUILT	AS-BUILT	AS-BUILT
CHECKED	AS-BUILT	AS-BUILT	AS-BUILT
APPROVED	AS-BUILT	AS-BUILT	AS-BUILT
DATE	AS-BUILT	AS-BUILT	AS-BUILT
BY	AS-BUILT	AS-BUILT	AS-BUILT

UNLESS OTHERWISE SPECIFIED	SHIP	NO	NO
FINISH	AS-BUILT	AS-BUILT	AS-BUILT
TEMPERATURE	AS-BUILT	AS-BUILT	AS-BUILT
STRESS	AS-BUILT	AS-BUILT	AS-BUILT
WELDING	AS-BUILT	AS-BUILT	AS-BUILT
THREADS	AS-BUILT	AS-BUILT	AS-BUILT
PLATING	AS-BUILT	AS-BUILT	AS-BUILT
COATING	AS-BUILT	AS-BUILT	AS-BUILT
PAINT	AS-BUILT	AS-BUILT	AS-BUILT
WARRANTY	AS-BUILT	AS-BUILT	AS-BUILT
REVISIONS	AS-BUILT	AS-BUILT	AS-BUILT
DATE	AS-BUILT	AS-BUILT	AS-BUILT
BY	AS-BUILT	AS-BUILT	AS-BUILT
CHECKED	AS-BUILT	AS-BUILT	AS-BUILT
APPROVED	AS-BUILT	AS-BUILT	AS-BUILT
DATE	AS-BUILT	AS-BUILT	AS-BUILT
BY	AS-BUILT	AS-BUILT	AS-BUILT

UNLESS OTHERWISE SPECIFIED	SHIP	NO	NO
FINISH	AS-BUILT	AS-BUILT	AS-BUILT
TEMPERATURE	AS-BUILT	AS-BUILT	AS-BUILT
STRESS	AS-BUILT	AS-BUILT	AS-BUILT
WELDING	AS-BUILT	AS-BUILT	AS-BUILT
THREADS	AS-BUILT	AS-BUILT	AS-BUILT
PLATING	AS-BUILT	AS-BUILT	AS-BUILT
COATING	AS-BUILT	AS-BUILT	AS-BUILT
PAINT	AS-BUILT	AS-BUILT	AS-BUILT
WARRANTY	AS-BUILT	AS-BUILT	AS-BUILT
REVISIONS	AS-BUILT	AS-BUILT	AS-BUILT
DATE	AS-BUILT	AS-BUILT	AS-BUILT
BY	AS-BUILT	AS-BUILT	AS-BUILT
CHECKED	AS-BUILT	AS-BUILT	AS-BUILT
APPROVED	AS-BUILT	AS-BUILT	AS-BUILT
DATE	AS-BUILT	AS-BUILT	AS-BUILT
BY	AS-BUILT	AS-BUILT	AS-BUILT

LAWRENCE BERKELEY LABORATORY

UNIVERSITY OF CALIFORNIA-BERKELEY

SNS-FES ION SOURCE AND LEIB

MECHANICAL SYSTEMS

LEIB ASSEMBLY

SCALE 1:2

DATE 02-10-14

SIZE 2167356

DESIGNER

DATE

SCALE

SIZE

DATE

SIZE

UNLESS OTHERWISE SPECIFIED

SHIP

NO

NO

NO

NO

FINISH

AS-BUILT

AS-BUILT

AS-BUILT

AS-BUILT

AS-BUILT

TEMPERATURE

AS-BUILT

AS-BUILT

AS-BUILT

AS-BUILT

AS-BUILT

STRESS

AS-BUILT

AS-BUILT

AS-BUILT

AS-BUILT

AS-BUILT

WELDING

AS-BUILT

AS-BUILT

AS-BUILT

AS-BUILT

AS-BUILT

THREADS

AS-BUILT

AS-BUILT

AS-BUILT

AS-BUILT

AS-BUILT

PLATING

AS-BUILT

AS-BUILT

AS-BUILT

AS-BUILT

AS-BUILT

COATING

AS-BUILT

AS-BUILT

AS-BUILT

AS-BUILT

AS-BUILT

PAINT

AS-BUILT

AS-BUILT

AS-BUILT

AS-BUILT

AS-BUILT

WARRANTY

AS-BUILT

AS-BUILT

AS-BUILT

AS-BUILT

AS-BUILT

REVISIONS

AS-BUILT

AS-BUILT

AS-BUILT

AS-BUILT

AS-BUILT

DATE

AS-BUILT

AS-BUILT

AS-BUILT

AS-BUILT

AS-BUILT

BY

AS-BUILT

AS-BUILT

AS-BUILT

AS-BUILT

AS-BUILT

CHECKED

AS-BUILT

AS-BUILT

AS-BUILT

AS-BUILT

AS-BUILT

APPROVED

AS-BUILT

AS-BUILT

AS-BUILT

AS-BUILT

AS-BUILT

DATE

AS-BUILT

AS-BUILT

AS-BUILT

AS-BUILT

AS-BUILT

BY

AS-BUILT

AS-BUILT

AS-BUILT

AS-BUILT

AS-BUILT