

REQ	ITEM	PART NUMBER	DESCRIPTION

NOTES (UNLESS OTHERWISE SPECIFIED):

- 1) DIMENSIONS IN INCHES.
- 2) MAKE FROM FITTING, 1/4" TUBING, SWAGelok/CAJON ULTRA-TORR NO. SS-4-UT-A-8BT (BORED THROUGH).
- 3) DISTRIBUTOR: OAKLAND VALVE & FITTING CO., CONCORD, CA, (510) 676-4100.

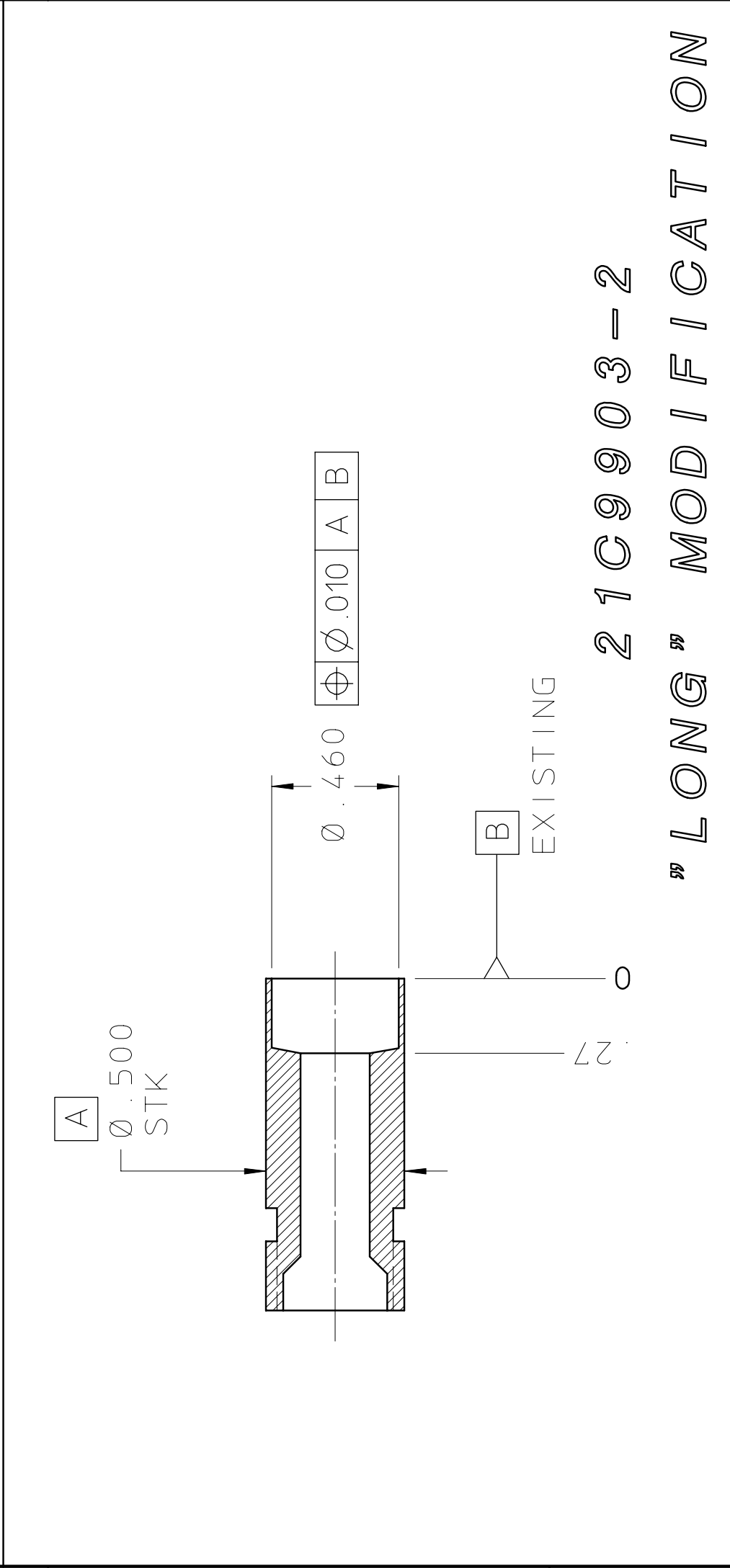
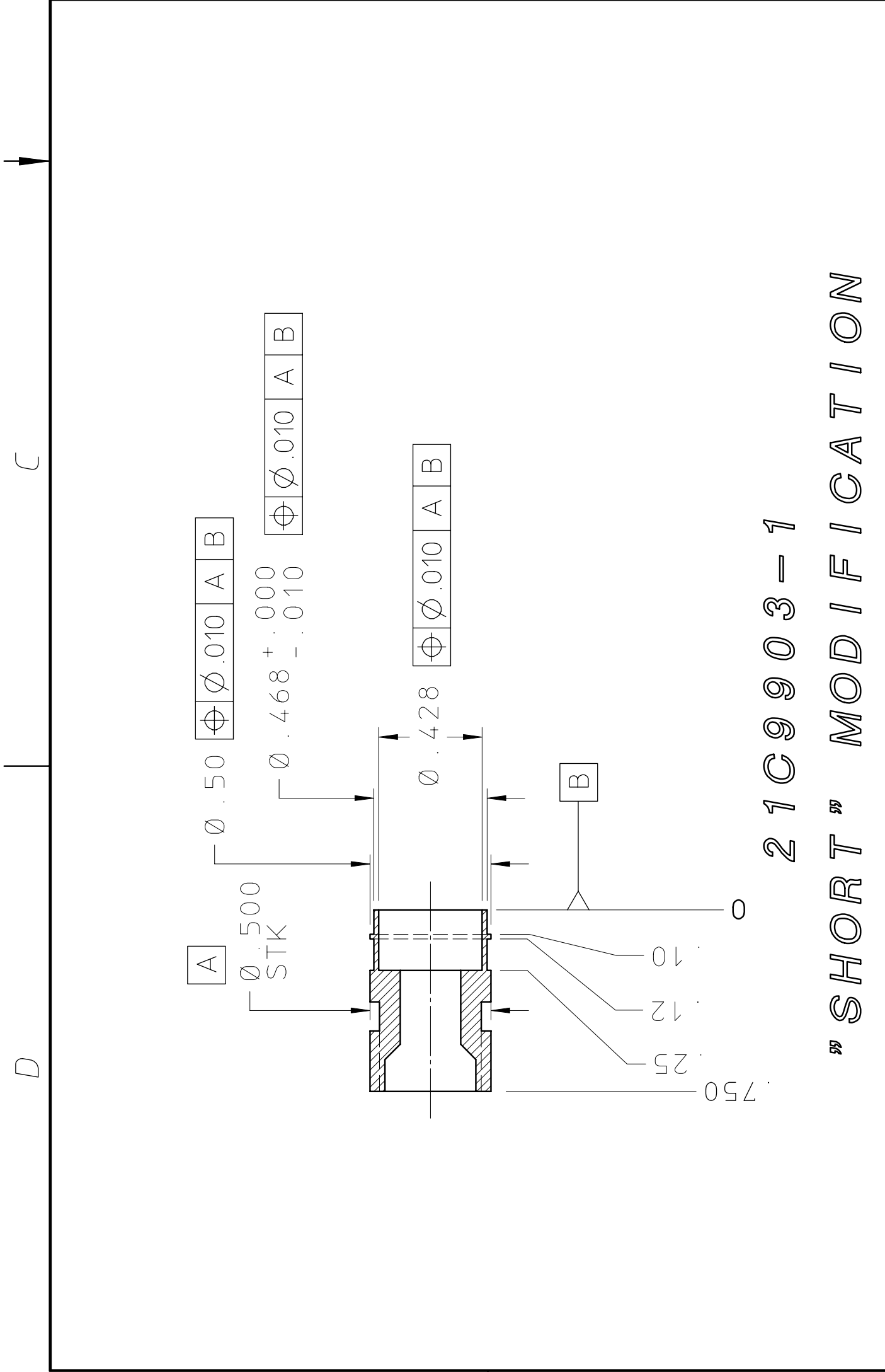
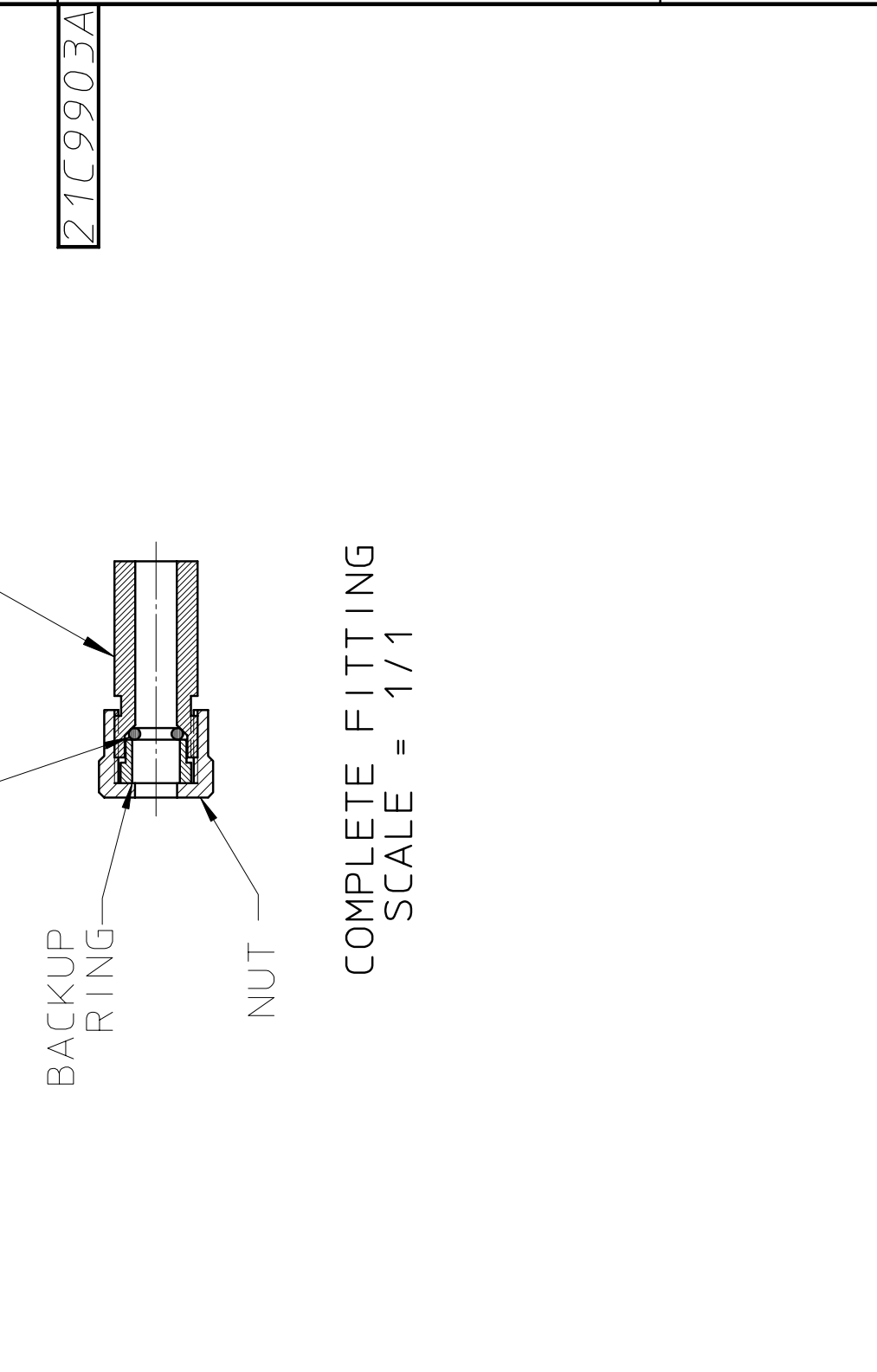

UNLESS OTHERWISE SPECIFIED		SHOP ORDERS		LAWRENCE BERKELEY LABORATORY	
.X ± .1	FRAC. ± 1/64	ACCT. NO.	SERIAL NO.	UNIVERSITY OF CALIFORNIA-BERKELEY	1
.XX ± .01	ANGLES ± .01°	DATE RECD.	DATE RECD.	SNS-FES ION SOURCE AND LEBT	2
XXX ± .002	FINISH 125√	DELIVER TO	NO. RECD.	MECHANICAL SYSTEMS	3
TOLERANCES		SURFACE TREATMENT		MODIFIED ULTRA-TORR FITTING	4
THREADS ARE CLASS 2		DEGREASE		PATENT CLEAR	1:2
CHAMFER ENDS OF ALL SCREW THREADS 30°		TAG		DETAIL	21C9894
CUT 1.5 PITCH THRD RELIEF WITH ROUND NOSE TOOL ON MACHINE CUT THREADS.		DMG. SKM		DESIGN ACCT. NO.	FE3111
BREAK EDGES .016 MAX. ON MACHINED WORK		BY		DMG. NO.	21C9903
REMOVE BURRS, WELD SPLATTER & LOOSE SCALE		CHK. D. CHENG		DATE	4/15/99
REFERENCES: ANST 114.5 & 846.1		DATE		DATE	4/30/99
REV	DMG	CHK	ZONE	DATE	CHANGES
A	DWC	ALL	6/13/00	GENERAL GEOM. UPDATE, ADDED TABULATED PART	