

Technical brochure

Pilot Controlled Servo Valves ICS



Contents

	Page
Introduction.....	3
Features.....	3
Design	4
Technical data	4
The ICS Concept	5
Function	7
Material specification - ICS 25, 32, 40, 50, 65	9
Material specification - ICS 100, 125, 150.....	10
Configuration examples	11
Nominal capacities:	
Liquid line with/without phase change	20
Liquid line without phase change	27
Wet suction line.....	33
Dry suction line	40
Discharge line	47
Ordering:	
ICS 25	54
ICS 32	55
ICS 40	56
ICS 50	57
ICS 65 and ICS 80	58
ICS 100 - 150.....	59
Accessories	60
Dimensions and weights:	
ICS 25	62
ICS 32	63
ICS 40	64
ICS 50	65
ICS 65	66
ICS 100	67
ICS 125	68
ICS 150	69
Connections.....	70

Introduction



ICS servo valves belong to the ICV (Industrial Control Valve) family and are one of two product groups.

ICV types

- ICS - Industrial Control Servo
- ICM - Industrial Control Motor

The valve comprises three main components: valve body, function module and top cover.

ICS servo valves are pilot operated valves for regulating pressure, temperature and ON/OFF function in refrigeration systems. ICS valves are designed for low and high-pressure refrigerants.

ICS valves can be used on the high and low-pressure sides, in wet and dry suction lines and in liquid lines without phase change (i.e. where no expansion takes place in the valve).

The function of ICS valves is dependent on the pilot pressure applied from either a pilot valve or external pilot pressure source.

ICS 1 pilot has one pilot pressure connection and ICS 3 pilot has three pilot pressure connections.

The associated Danfoss pilot valves can be either screwed directly into the ICS valve or connected via an external pilot line. Several pilot valves can be used on one ICS valve to provide numerous variations in control functions.

The ICS valve top cover includes a pressure gauge connection port which can be used to monitor the valve inlet pressure when setting and adjusting the pilot valves.

The spindle in the top cover can be used for manually opening the ICS valve.

Features

- Designed for industrial refrigeration applications for a maximum working pressure of 52 bar g/754 psi g.
- ICS 25-150: Applicable for all common refrigerants including R717 and R744 (CO₂) and non corrosive gases/liquids.
- Direct coupled connections
- Connection types include butt weld, socket weld, solder and threaded connections.
- Low temperature steel body
- Low weight and compact design.
- V-port regulating cone ensures optimum regulating accuracy particularly at part load.
- Function module has a QPQ surface treated insert and a steel piston ring ensuring precise control accuracy.
- ICV 4", 5" and 6" ANSI with NPT threaded pressure outlet in the outlet of the valve.
- Replaceable Teflon valve seat for ICS 25-80
- Maintenance spare part kit available for ICS 100-150.
- Modular Concept
 - Each valve body is available with several different connection types and sizes
 - Valve overhaul on ICS 25-80 is done by replacing the function module
 - Possible to convert ICS servo to ICM motor valve
- Manual opening.
- The ICS valve is a multifunction valve where several pilot valves can be mounted into the pilot ports.
- The standard range of pilot valves can be used on all sizes of ICS valves. Pilot valves can be either screwed directly into the ICS valve, thus eliminating the need for solder/weld connections or external pilot lines.
- Pressure gauge connection port to measure valve inlet pressure.
- The top cover can be rotated into any possible position without affecting the operation of the valve.

Design

ICS valves are designed as pilot operated valves requiring minimal pressure differential to open. If the pressure difference is 0 bar/0 psi, the ICS valve will be closed. If the pressure difference is 0.2 bar/3 psi or more, the ICS valve will be fully open. At pressure differences between 0.07 bar/1 psi and 0.2 bar /3 psi, the opening degree will be correspondingly proportional.

The ICS is available for use with either one or three pilot valves.

Two of the three pilot pressure connections (S1 and S2) are connected in series whilst the third (P) is connected in parallel to S1 and S2. This allows different combinations of pilot valves to be used, thus providing numerous variations in control functions.

Connections

There is a very wide range of connection types available with ICS valves:

- D: Butt weld, DIN (2448)
- A: Butt weld, ANSI (B 36.10)
- J: Butt weld, JIS (B S 602)
- SOC: Socket weld, ANSI (B 16.11)
- SD: Solder connection, DIN (2856)
- SA: Solder connection, ANSI (B 16.22)
- FPT: Female pipe thread (ANSI/ASME B 1.20.1)

Approvals

The ICV valve concept is designed to fulfill global refrigeration requirements.

For specific approval information, please contact Danfoss.

The ICS valves are approved in accordance with the European standard specified in the Pressure Equipment Directive and are CE marked.

For further details / restrictions - see Installation Instruction

Valve body and top cover material

Low temperature steel



ICS valves			
Nominal bore	DN≤ 25 (1 in.)	DN 32-65 (1 1/4 - 2 1/2 in.)	DN 80-125 (3 - 5 in.)
Classified for	Fluid group I		
Category	Article 3, paragraph 3	II	III

Technical data

- *Refrigerants*
Applicable to all common refrigerants including R717 and R744 (CO₂) and non-corrosive gases/liquids. Use with flammable hydrocarbons cannot be recommended; please contact Danfoss.
- *Temperature range*
-60/+120°C (-76/+248°F).
- *Surface protection*
ICS 25-150:
The external surface is zinc-chromated to provide good corrosion protection.

- *Pressure range*
The valve is designed for:
Max. working pressure: 52 bar g (754 psig)
- Opening differential pressure:*
Fully open: Min. 0.2 bar g (min. 3 psig)
Max. Opening Pressure Differential (MOPD), solenoid valves only - at nominal conditions.
 - 10 W a.c. up to 21 bar (305 psi)
 - 20 W a.c. up to 40 bar (580 psi)

The ICS Concept

The ICS concept is developed around a modular principle. This gives the possibility of combining function modules and top covers with special valve body size that is available in a variety of connection possibilities.

- There are eight valve bodies available.

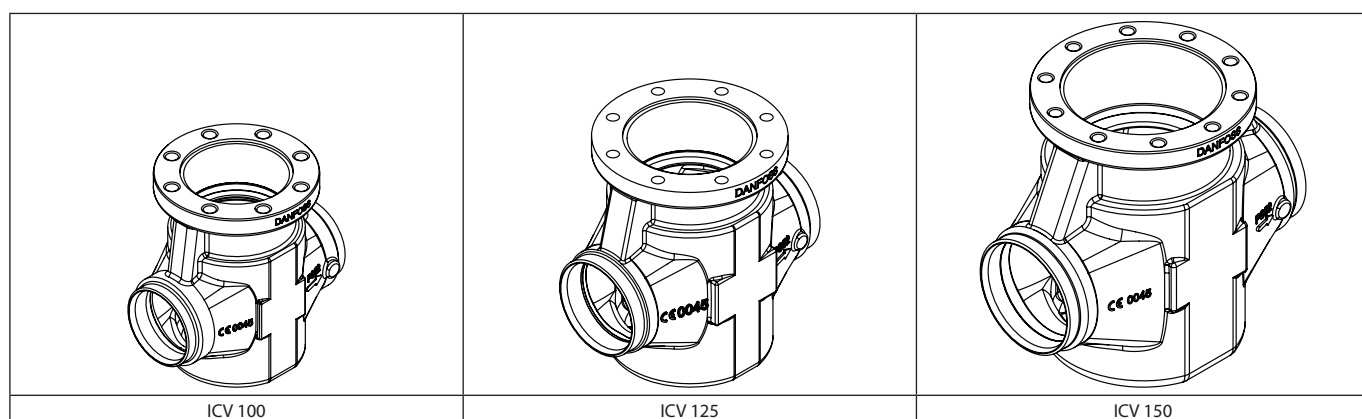
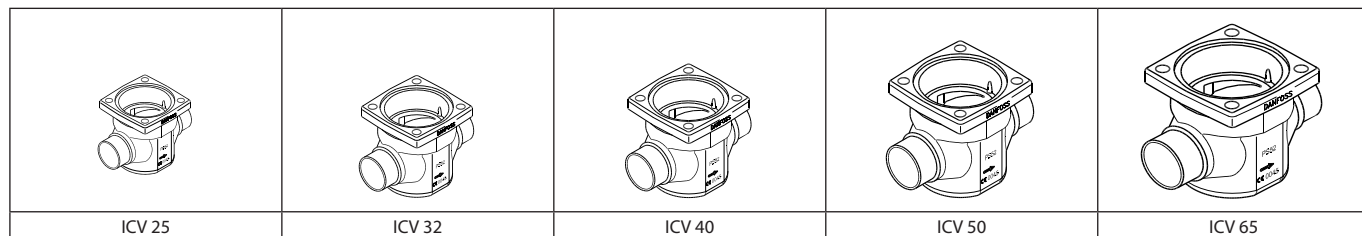

- Valve bodies in the sizes ICV 20-ICV65 are available with a range of undersizes through oversized connection sizes and types. ICV 100 - ICV 150 are available in butt-weld DIN and butt-weld ANSI nominal sizes

D	A	J	SOC	SD	SA	FPT
Butt-weld DIN	Butt-weld ANSI	Butt-weld JIS	Socket weld ANSI	Solder DIN	Solder ANSI	Female Pipe Thread

- Each valve body may be fitted with a 1 pilot or 3 pilot top cover.

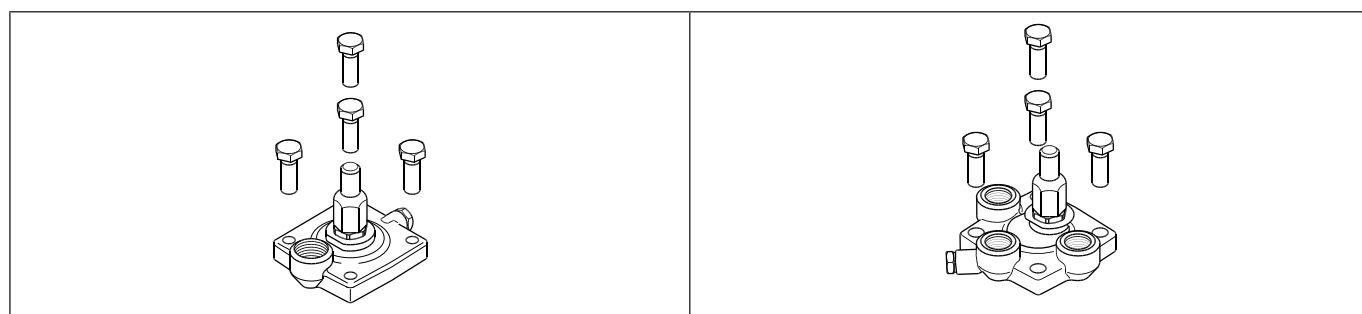

The ICS Concept
(continued)

In ICS, multiple inserts (function modules) are available to give different capacities.

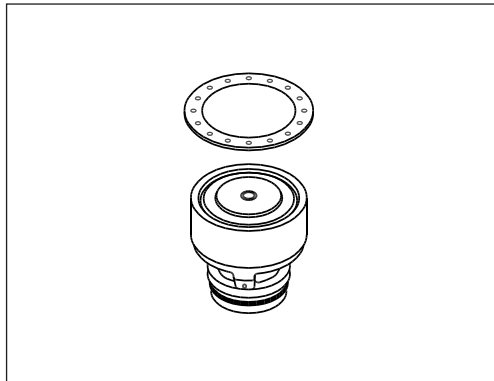

Type	Valve body size	K _v (m ³ /h)	C _v (USgal/min)
ICS 25-5	25	1.7	2.0
ICS 25-10		3.5	4.1
ICS 25-15		6.0	7.0
ICS 25-20		8	9.3
ICS 25-25		11.5	13.3
ICS 32	32	17	20
ICS 40	40	27	31
ICS 50	50	44	51
ICS 65	65	70	81
ICS 80	80	85	98
ICS 100	100	142	165
ICS 125	125	207	240
ICS 150	150	354	410

Function

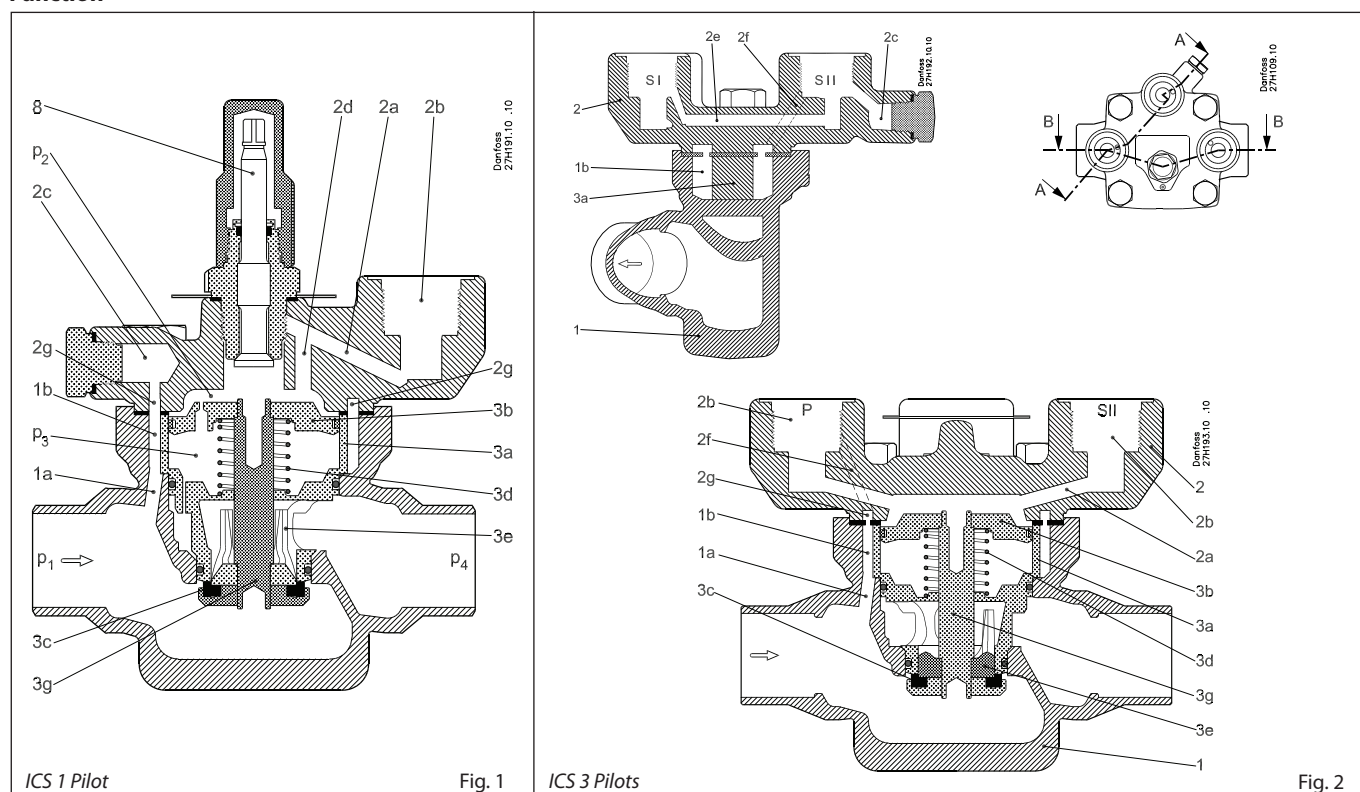

ICS 1 Pilot and ICS 3 Pilot

1. Body
- 1a Pilot channel to inlet side
- 1b Circular gap between house and module
2. Top cover
- 2a Pilot channels in top cover
- 2b Pilot insertion hole
- 2c Pressure gauge connection
- 2d Piston top inlet channel
- 2e Cross channel SI to SII
- 2f Inlet channel
- 2g Circular groove
- 3 Function module
- 3a Cylinder
- 3b Piston
- 3c Valve plate
- 3d Spring
- 3e Cone
- 3f Equalisation orifice
- 3g Piston rod

- p_1 Inlet pressure
 p_2 Pressure on piston
 p_3 Pressure underneath piston
 p_4 Outlet pressure
 8 Manual operating spindle

The ICS main valve is a pilot operated valve. The types of pilot valves used determine the function. The ICS main valve with pilot valve(s) controls refrigerant flow by modulation or on/off in accordance with the pilot valve and main valve status. The manual spindle can be used to open the valve plate.

The opening degree of the main valve is determined by the pressure difference (differential pressure) between pressure p_2 , which acts on top of the servo piston (3b), and pressure p_3 , which acts on the underside of the servo piston.

If this pressure difference is 0, the main valve will be fully closed.

If the pressure difference is 0.2 bar (3 psi) or greater, the main valve will be fully open. At pressure differences ($p_2 - p_3$) between 0.07 bar (1 psi) and 0.2 bar (3 psi), the degree of opening will be correspondingly proportional.

The port of the throttle cone (3e) is V-shaped, which provide good regulation characteristic to pilot operated main valves even at low loads. P_3 pressure is equal to the valve outlet pressure (P_4), due to a clearance between the piston rod (3g) and the function module. The opening degree of the ICS valve is therefore controlled by the application of P_2 pressure acting on top of the servo piston, which is equal to or greater than valve outlet pressure (P_4).

$p_2 = p_4 \sim$ closed
 $p_2 = p_4 + 0.2 \text{ bar (3 psi)} \sim$ fully open
 $p_4 \leq p_2 \leq p_4 + 0.2 \text{ bar (3 psi)} \sim$ proportional degree of opening.

The maximum pressure (p_2) can act on the top of the servo piston (3b). p_2 normally corresponds to the pressure, p_1 - ICS main valve inlet pressure. Inlet pressure p_1 is led, via the drilled channels (1a, 1b, 2f, 2b (pilot), 2a, 2d) in the valve body (1) and cover (2) through the individual pilot valves and onto the top of the servo piston (3b).

The degree of opening of the individual pilot valves determines the magnitude of pressure p_2 and thus the degree of opening of the main valve. The equalisation hole (3f) in the servo piston (3b) ensures that pressure p_2 is balanced in accordance with the degree of opening of the pilot valve.

Note:

When ICS valves with 3 pilot ports are used with external pressure connector (fig. 2, pos. 61), the valve port inlet pressure will be isolated.

The ICS can be fitted with just a single screwed-in pilot valve or external pilot connection. The degree of opening of the main valve will be in accordance with the control status of the pilot valve or external pilot flow control. ICS main valve with one pilot connection is fully closed when the pilot valve is fully closed and fully open when the pilot valve is fully open. Otherwise the degree of opening of the main valve is proportional to the degree of opening of the pilot valve.

The ICS 3 pilot version can be fitted with one, two, or three pilot valves so that up to three regulating functions are possible. If the external pilot connection is used, more functions can be added.

Function (continued)

In the ICS three pilot version, the pilot ports are related as follows:

- The pilot valves fitted in ports SI and SII are connected in series.
The ICS 3 pilot operated main valve will be fully closed if just one of the series-connected pilot valves is closed. The main valve can only open if both pilot valves are open at the same time.
- The pilot valve fitted in port P is connected in parallel to the pilot valves in ports SI and SII.

The ICS valve will be fully open if the pilot valve in P is fully open, irrespective of the degree of opening of pilot valves SI and SII.
The ICS valve will be fully closed if the pilot valve in P is fully closed and at least one of the valves in SI or SII is fully closed at the same time. The relation between the pilot valves in ports SI, SII and P is shown in the table on the next page.

If the ICS is not fitted with three pilot valves, the unused port(s) must be sealed with a blanking plug. If the blanking plug is fitted as an assembled unit, A + B, the channels from the specific port will be closed. (See illustration below)

If only the top part, A, of the plug is fitted, the channels from the ports in question will be open. If the degree of opening of the ICS main valve is not to be a function of the main valve inlet pressure, or if more than three regulating

functions are required, ports SI, SII or P can be fitted with a nipple for the connection of external pilot pressure. This applies to all ICS versions.

The pressure to which the external pilot line is connected will then determine pressure p_2 on top of the servo piston. The pilot valves fitted in that external pilot line will determine the main valve function. Pilot valves installed in external lines must be mounted in a type CVH housing.

Depending on the function of the pilot valves, the ICS regulating characteristic becomes:

- on/off
- proportional
- integral or
- cascade.

ICS main valves are therefore especially suitable for all forms of temperature and pressure regulating systems.

An overview of the types of pilot valves available can be found in the literature "Pilot valves for operated main valves" (DKRCI.PD.HN0).

On the following pages, a number of configuration examples can be found. These are only for explanatory purpose. However, by using the literature regarding pilot valves these examples are easier to comprehend.

Pilot valve port			ICS valve
SI	SII	P	
Open	Open	Closed	Open
Open	Open	Open	Open
Open	Closed	Closed	Closed
Open	Closed	Open	Open
Closed	Open	Closed	Closed
Closed	Open	Open	Open
Closed	Closed	Closed	Closed
Closed	Closed	Open	Open

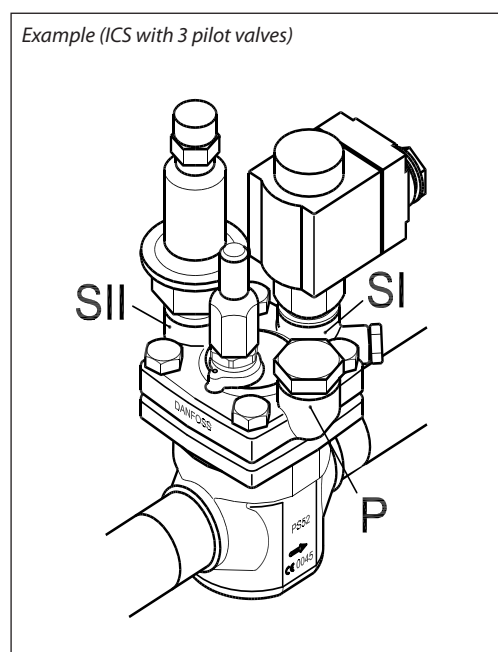
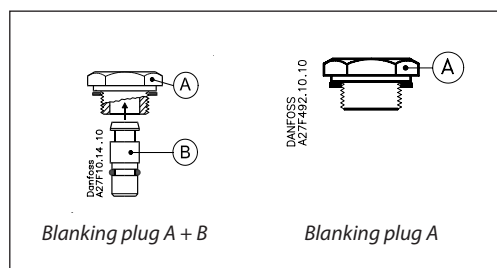

Material specification - ICS 25, 32, 40, 50, 65

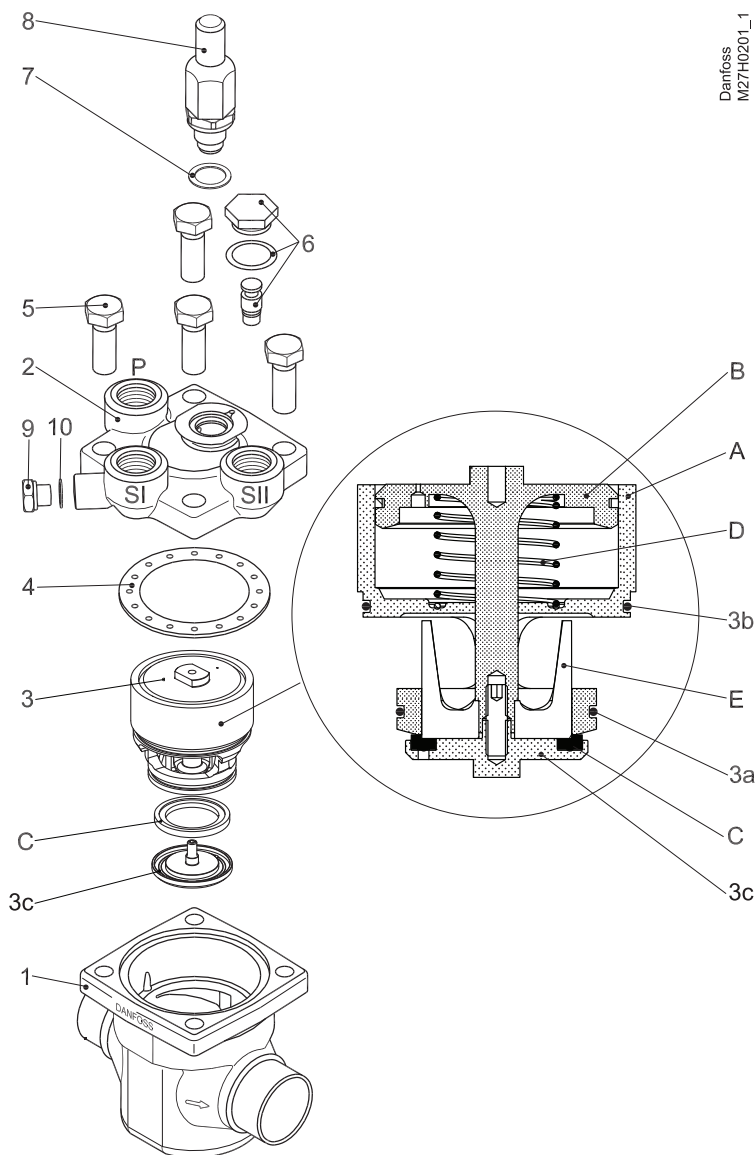

Type and size of Bolt (pos. 5)

Type	Screw
ICS 25	M12 × 30 A2-70 DIN 933
ICS 32	M14 × 35 A2-70 DIN 933
ICS 40	M14 × 40 A2-70 DIN 933
ICS 50	M16 × 40 A2-70 DIN 933
ICS 65	M16 × 50 A2-70 DIN 933

No.	Part	Material	EN	ASTM	JIS
1	Body	Low temperature steel	G20Mn5QT, EN 10213-3	LCC A352	SCPL1 G5151
2	Top cover	Low temperature steel	G20Mn5QT, EN 10213-3 P285QH+QT 10222-4	LCC A352 LF2, A350	SCPL1 G5151
3	Function module (assembled)				
3a	o-ring	Cloroprene (Neoprene)			
3b	o-ring	Cloroprene (Neoprene)			
3c	Washer plate	Steel			
A	Cylinder	Steel			
B	Piston	Steel			
C	Valve plate	PTFE			
D	Spring	Steel			
E	Cone	Steel			
4	Gasket	Fiber, non-asbestos			
5	Bolts	Stainless steel	A2-70, EN 1515-1	Grade B8 A320	A2-70, B 1054
6	Plug	Steel			
7	Gasket	Aluminium			
8	Manual operating spindle	Steel			
9	Plug	Steel			
10	Gasket	Aluminium			

Material specification - ICS 100, 125, 150

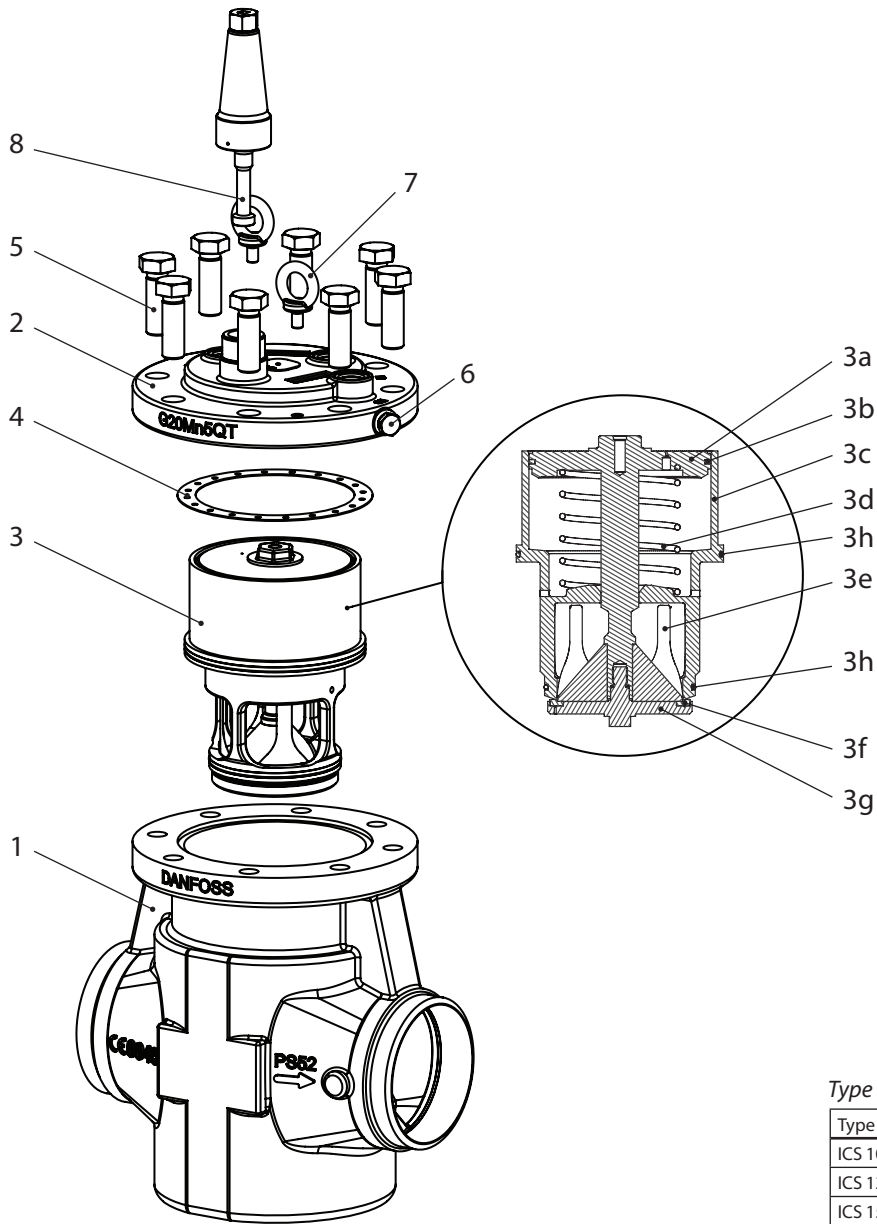

Type and size of Bolt (pos. 5)

Type	Screw
ICS 100	M20 × 60 A2-70 DIN 933
ICS 125	M20 × 60 A2-70 DIN 933
ICS 150	M20 × 70 A2-70 DIN 933

No.	Part	Material	EN	ASTM	JIS
1	Body	Low temperature steel	G20Mn5QT, EN 10213-3	LCC A352	SCPL1 G5151
2	Top cover	Low temperature steel	G20Mn5QT, EN 10213-3	LCC A352	SCPL1 G5151
3	Function module (assembled)				
3a	Piston/rod	Stainless steel / steel			
3b	Piston ring	Steel			
3c	Insert	Steel			
3d	Spring	Steel			
3e	Cone	Stainless steel / steel			
3f	Teflon plate	Teflon unfilled			
3g	Washer plate	PTFE			
3h	o-ring	Cloroprene (Neoprene)			
4	Gasket	Fiber, non-asbestos			
5	Bolts	Stainless steel	A2-70, EN 1515-1	Grade B8 A320	A2-70, B 1054
6	Plug	Steel			
7	Eye bolt	Galvanized steel			
8	Manual operating spindle	Steel			

Configuration examples

<p><i>Example no. 1-1</i></p> <p>Constant pressure regulation. -0.66 to 7 bar g (19.5 in. Hg to 102 psig).</p>		<p><i>Products</i></p> <p>1 × ICS 1 Pilot 1 × CVP (LP)</p>		<p><i>Products</i></p> <p>1 × ICS 3 Pilots 1 × CVP (LP) 2 × Blanking plugs SI: A + B SII: A</p>	
<p><i>Example no. 1-2</i></p> <p>Differential pressure regulation. 0 to 7 bar g (0 to 102 psig).</p>		<p><i>Products</i></p> <p>1 × ICS 1 Pilot 1 × CVPP (LP)</p>		<p><i>Products</i></p> <p>1 × ICS 3 Pilots 1 × CVPP (LP) 2 × Blanking plugs SI: A + B SII: A</p>	
<p><i>Example no. 1-3</i></p> <p>Temperature regulation. -40 to 60°C (-40 to 140°F). Opening at rising temperature. Pressure independent.</p>		<p><i>Products</i></p> <p>1 × ICS 1 Pilot 1 × CVT</p>		<p><i>Products</i></p> <p>1 × ICS 3 Pilots 1 × CVT 2 × Blanking plugs SI: A + B SII: A</p>	
<p><i>Example no. 1-4</i></p> <p>Temperature regulation. -40 to 60°C (-40 to 140°F). Closing at rising temperature. Pressure independent.</p>		<p><i>Products</i></p> <p>1 × ICS 1 Pilot 1 × CVTO</p>		<p><i>Products</i></p> <p>1 × ICS 3 Pilots 1 × CVTO 2 × Blanking plugs SI: A + B SII: A</p>	
<p><i>Example no. 1-5</i></p> <p>On/off regulation (solenoid valve).</p>		<p><i>Products</i></p> <p>1 × ICS 1 Pilot 1 × EVM 1 × coil</p>		<p><i>Products</i></p> <p>1 × ICS 3 Pilots 1 × EVM 1 × coil 2 × Blanking plugs SI: A + B SII: A</p>	

Configuration examples (continued)

<p>Example no. 1-6</p> <p>Regulation with external control pressure.</p>		<p>Products</p> <p>1 × ICS 1 Pilot 1 × nipple for external control pressure</p>		<p>Products</p> <p>1 × ICS 3 Pilots 1 × nipple for external control pressure 2 × Blanking plugs SI: A + B SII: A</p>	
<p>Example no. 1-7</p> <p>Constant pressure regulation. -0.66 to 28 bar g (19.5 in. Hg to 406 psig).</p>		<p>Products</p> <p>1 × ICS 1 Pilot 1 × CVP (HP)</p>		<p>Products</p> <p>1 × ICS 3 Pilots 1 × CVP (HP) 2 × Blanking plugs SI: A + B SII: A</p>	
<p>Example no. 1-8</p> <p>Differential pressure regulation. 0 to 22 bar g (0 to 319 psig).</p>		<p>Products</p> <p>1 × ICS 1 Pilot 1 × CVPP (HP)</p>		<p>Products</p> <p>1 × ICS 3 Pilots 1 × CVPP (HP) 2 × Blanking plugs SI: A + B SII: A</p>	
<p>Example no. 1-9</p> <p>On/off regulation (solenoid valve).</p>		<p>Products</p> <p>1 × ICS 1 Pilot 1 × EVM-NO (12 W coil)</p>		<p>Products</p> <p>1 × ICS 3 Pilots 1 × EVM-NO (12 W coil) 2 × Blanking plugs SI: A + B SII: A</p>	
<p>Example no. 1-10</p> <p>Crankcase pressure regulation. (Max. suction pressure regulation) -0.45 to 7 bar g (13.3 in. Hg to 102 psig).</p>		<p>Products</p> <p>1 × ICS 1 Pilot 1 × CVC</p>		<p>Products</p> <p>1 × ICS 3 Pilots 1 × CVC 2 × Blanking plugs SI: A + B SII: A</p>	

For further information please see the PMC and CVC technical leaflet (RD4ED).

Configuration examples (continued)

<p><i>Example no. 1-11</i></p> <p>Electronically controlled media temperature regulation. -1 to 8 bar g (0 in. Hg to 116 psig).</p>		<p><i>Products</i></p> <p>1 × ICS 1 Pilot 1 × CVQ</p>		<p><i>Products</i></p> <p>1 × ICS 3 Pilots 1 × CVQ 2 × Blanking plugs SI: A + B SII: A</p>	
<p><i>Example no. 3-1</i></p> <p>Constant pressure regulation combined with electrical shut off. -0.66 to 7 bar g (19.5 in. Hg to 102 psig).</p>		<p><i>Products</i></p> <p>1 × ICS 3 Pilots 1 × blanking plug (A + B) 1 × CVP (LP) 1 × EVM 1 × coil</p>			
<p><i>Example no. 3-2</i></p> <p>Constant pressure regulation combined with electrical wide open. -0.66 to 7 bar g (19.5 in. Hg to 102 psig).</p>		<p><i>Products</i></p> <p>1 × ICS 3 Pilots 1 × blanking plug (A) 1 × CVP (LP) 1 × EVM</p>			
<p><i>Example no. 3-3</i></p> <p>Constant pressure regulation combined with electrical shut off and wide open. -0.66 to 7 bar g (19.5 in. Hg to 102 psig).</p>		<p><i>Products</i></p> <p>1 × ICS 3 Pilots 1 × CVP (LP) 2 × EVM 2 × coils</p>			
<p><i>Example no. 3-4</i></p> <p>Constant pressure regulation with change-over between two preset evaporating pressures. -0.66 to 7 bar g (19.5 in. Hg to 102 psig).</p>		<p><i>Products</i></p> <p>1 × ICS 3 Pilots 2 × CVP (LP) 1 × EVM 1 × coil</p>			

Configuration examples (continued)

<p>Example no. 3-5</p> <p>External control pressure with electrical shut off combined with constant pressure regulation. -0.66 to 7 bar g (19.5 in. Hg to 102 psig).</p>		<p>Products</p> <ul style="list-style-type: none"> 1 × ICS 3 Pilots 1 × nipple for external control pressure 1 × CVP (LP) 1 × EVM 1 × coil 	
<p>Example no. 3-6</p> <p>Constant pressure regulation with external control pressure combined with electrical wide open. -0.66 to 7 bar g (19.5 in. Hg to 102 psig).</p>		<p>Products</p> <ul style="list-style-type: none"> 1 × ICS 3 Pilots 1 × nipple for external control pressure 1 × CVP (LP) 1 × EVM 1 × coil 	
<p>Example no. 3-7</p> <p>Constant pressure regulation with electrical shut off combined with external control pressure. -0.66 to 7 bar g (19.5 in. Hg to 102 psig).</p>		<p>Products</p> <ul style="list-style-type: none"> 1 × ICS 3 Pilots 1 × nipple for external control pressure 1 × CVP (LP) 1 × EVM 1 × coil 	
<p>Example no. 3-8</p> <p>Solenoid valve with external control pressure for small pressure drops.</p>		<p>Products</p> <ul style="list-style-type: none"> 1 × ICS 3 1 × blanking plug (A + B) 1 × nipple for external control pressure 1 × EVM 1 × coil 	
<p>Example no. 3-9</p> <p>Differential pressure regulation combined with electrical shut off. 0 to 7 bar g (0 to 102 psig).</p>		<p>Products</p> <ul style="list-style-type: none"> 1 × ICS 3 1 × blanking plug (A + B) 1 × CVPP (LP) 1 × EVM 1 × coil 	

Configuration examples (continued)

<p>Example no. 3-10</p> <p>Differential pressure regulation combined with electrical wide open. 0 to 7 bar g (0 to 102 psig).</p>		<p>Products</p> <ul style="list-style-type: none"> 1 × ICS 3 Pilots 1 × blanking plug (A) 1 × CVPP (LP) 1 × EVM 1 × coil 	
<p>Example no. 3-11</p> <p>Differential pressure regulation combined with electrical wide open and shut off. 0 to 7 bar g (0 to 102 psig).</p>		<p>Products</p> <ul style="list-style-type: none"> 1 × ICS 3 Pilots 1 × CVPP (LP) 2 × EVM 2 × coils 	
<p>Example no. 3-12</p> <p>Thermostatic regulation combined with electrical shut off. Pressure independent. -40 to 60°C (-40 to 140°F).</p>		<p>Products</p> <ul style="list-style-type: none"> 1 × ICS 3 Pilots 1 × blanking plug (A + B) 1 × CVT 1 × EVM 1 × coil 	
<p>Example no. 3-13</p> <p>Thermostatic regulation combined with electrical wide open. Pressure independent. -40 to 60°C (-40 to 140°F).</p>		<p>Products</p> <ul style="list-style-type: none"> 1 × ICS 3 Pilots 1 × blanking plug (A) 1 × CVT 1 × EVM 1 × coil 	
<p>Example no. 3-14</p> <p>Thermostatic regulation with protection against too low evaporating pressure. -40 to 60°C (-40 to 140°F). -0.66 to 7 bar g (19.5 in. Hg to 102 psig).</p>		<p>Products</p> <ul style="list-style-type: none"> 1 × ICS 3 Pilots 1 × blanking plug (A + B) 1 × CVT 1 × CVP 	

Configuration examples (continued)

<p>Example no. 3-15</p> <p>Constant pressure regulation combined with electrical shut off. -0.66 to 28 bar g (19.5 in. Hg to 406 psig).</p>		<p>Products</p> <ul style="list-style-type: none"> 1 × ICS 3 Pilots 1 × blanking plug (A + B) 1 × CVP (HP) 1 × EVM 1 × coil 	
<p>Example no. 3-16</p> <p>Constant pressure regulation combined with electrical wide open. -0.66 to 28 bar g (19.5 in. Hg to 406 psig).</p>		<p>Products</p> <ul style="list-style-type: none"> 1 × ICS 3 Pilots 1 × blanking plug (A) 1 × CVP (HP) 1 × EVM 1 × coil 	
<p>Example no. 3-17</p> <p>Constant pressure regulation combined with electrical shut off and wide open. -0.66 to 28 bar g (19.5 in. Hg to 406 psig).</p>		<p>Products</p> <ul style="list-style-type: none"> 1 × ICS 3 Pilots 1 × CVP (HP) 2 × EVM 2 × coils 	
<p>Example no. 3-18</p> <p>Constant pressure regulation with change-over between two preset evaporating pressures. -0.66 to 28 bar g (19.5 in. Hg to 406 psig).</p>		<p>Products</p> <ul style="list-style-type: none"> 1 × ICS 3 Pilots 2 × CVP (HP) 1 × EVM 1 × coil 	
<p>Example no. 3-19</p> <p>Differential pressure regulation combined with electrical shut off. 0 to 22 bar g (0 to 319 psig).</p>		<p>Products</p> <ul style="list-style-type: none"> 1 × ICS 3 Pilots 1 × blanking plug (A + B) 1 × CVPP (HP) 1 × EVM 1 × coil 	

Configuration examples (continued)

<p>Example no. 3-20</p> <p>Differential pressure regulation combined with electrical wide open. 0 to 22 bar g (0 to 319 psig).</p>	<p style="text-align: right; font-size: small;">Danfoss 27H53.10</p>	<p>Products</p> <ul style="list-style-type: none"> 1 × ICS 3 Pilots 1 × blanking plug (A) 1 × CVPP (HP) 1 × EVM 1 × coil 	
<p>Example no. 3-21</p> <p>Differential pressure regulation combined with electrical wide open and shut off. 0 to 22 bar g (0 to 319 psig).</p>	<p style="text-align: right; font-size: small;">Danfoss 27H54.10</p>	<p>Products</p> <ul style="list-style-type: none"> 1 × ICS 3 Pilots 1 × CVPP (HP) 2 × EVM 2 × coils 	
<p>Example no. 3-22</p> <p>Constant pressure regulation combined with electrical wide open and shut off. -0.66 to 28 bar g (19.5 in. Hg to 406 psig).</p>	<p style="text-align: right; font-size: small;">Danfoss 27H55.10</p>	<p>Products</p> <ul style="list-style-type: none"> 1 × ICS 3 Pilots 1 × CVP (HP) 1 × EVM 1 × EVM-NO (12 W coil) 2 × coils 	
<p>Example no. 3-23</p> <p>Crankcase pressure regulation (max. suction pressure regulation) combined with shut off. -0.45 to 7 bar g (13.3 in. Hg to 102 psig).</p>	<p style="text-align: right; font-size: small;">Danfoss 27H56.10</p>	<p>Products</p> <ul style="list-style-type: none"> 1 × ICS 3 Pilots 1 × blanking plug (A + B) 1 × CVC 1 × EVM 1 × coil 	
<p>Example no. 3-24</p> <p>Crankcase pressure regulation (max. suction pressure regulation) combined with evaporating pressure regulation. -0.66 to 28 bar g (19.5 in. Hg to 406 psig).</p>	<p style="text-align: right; font-size: small;">Danfoss 27H57.10</p>	<p>Products</p> <ul style="list-style-type: none"> 1 × ICS 3 Pilots 1 × blanking plug (A + B) 1 × CVC 1 × CVP(LP) 	

Configuration examples (continued)

Example no. 3-25

Crankcase pressure regulation (max. suction pressure regulation) at low pressure drops across the valve.
-0.45 to 7 bar g
(13.3 in. Hg to 102 psig).

Products

- 1 × ICS 3 Pilots
- 1 × blanking plug (A + B)
- 1 × nipple for external control pressure
- 1 × CVC

Example no. 3-26

Crankcase pressure regulation (max. suction pressure regulation) combined with constant pressure regulation and electrical shut off.
-0.66 to 7 bar g
(19.5 in. Hg to 102 psig).

Products

- 1 × ICS 3 Pilots
- 1 × blanking plug (A + B)
- 1 × nipple for external control pressure
- 1 × CVP (LP)
- 1 × EVM
- 1 × coil
- 2 × CVH
- 1 × CVC

Example no. 3-27

Hot gas bypass regulation combined with electrical shut off.
-0.45 to 7 bar g
(13.3 in. Hg to 102 psig).

Products

- 1 × ICS 3 Pilots
- 1 × blanking plug (A + B)
- 1 × CVC
- 1 × EVM
- 1 × coil

Example no. 3-28

Constant pressure regulation with electrical shut off and protection against high pressure when suction line is closed.
-0.66 to 28 bar g
(19.5 in. Hg to 406 psig).

Products

- 1 × ICS 3 Pilots
- 1 × CVP (LP)
- 1 × EVM
- 1 × coil
- 1 × CVP (HP)

Example no. 3-29

Electronically controlled media temperature regulation combined with electrical shut off.
-1 to 8 bar g
(0 in. Hg to 116 psig).

Products

- 1 × ICS 3 Pilots
- 1 × blanking plug (A + B)
- 1 × CVQ
- 1 × EVM
- 1 × coil

Configuration examples (continued)

<p><i>Example no. 3-30</i></p> <p>Electronically controlled media temperature regulation combined with electrical shut off and wide open. -1 to 8 bar g (0 in. Hg to 116 psig).</p>	<p style="text-align: right; font-size: small;">Danfoss Z7162.1.0</p>	<p><i>Products</i></p> <p>1 × ICS 3 Pilots 1 × CVQ 2 × EVM 2 × coils</p>	
<p><i>Example no. 3-31</i></p> <p>Electronically controlled media temperature regulation combined with electrical shut off and changeover to constant pressure regulation. -1 to 8 bar g (0 in. Hg to 116 psig).</p>	<p style="text-align: right; font-size: small;">Danfoss Z7162.1.0</p>	<p><i>Products</i></p> <p>1 × ICS 3 Pilots 1 × CVQ 1 × CVP (LP) 1 × EVM 1 × coil</p>	
<p><i>Example no. 3-32</i></p> <p>Electronically controlled media temperature regulation with low evaporating pressure protection combined with wide open. -1 to 8 bar g (0 in. Hg to 116 psig).</p>	<p style="text-align: right; font-size: small;">Danfoss Z7162.1.0</p>	<p><i>Products</i></p> <p>1 × ICS 3 Pilots 1 × CVQ 1 × CVP (LP) 1 × EVM 1 × coil</p>	
<p><i>Example no. 3-33</i></p> <p>Electronically controlled media temperature regulation with low evaporating pressure protection combined with changeover to constant pressure regulation. -1 to 8 bar g (0 in. Hg to 116 psig).</p>	<p style="text-align: right; font-size: small;">Danfoss Z7162.1.0</p>	<p><i>Products</i></p> <p>1 × ICS 3 Pilots 1 × CVQ 2 × CVP (LP)</p>	

Nominal capacities

Liquid line with/without phase change

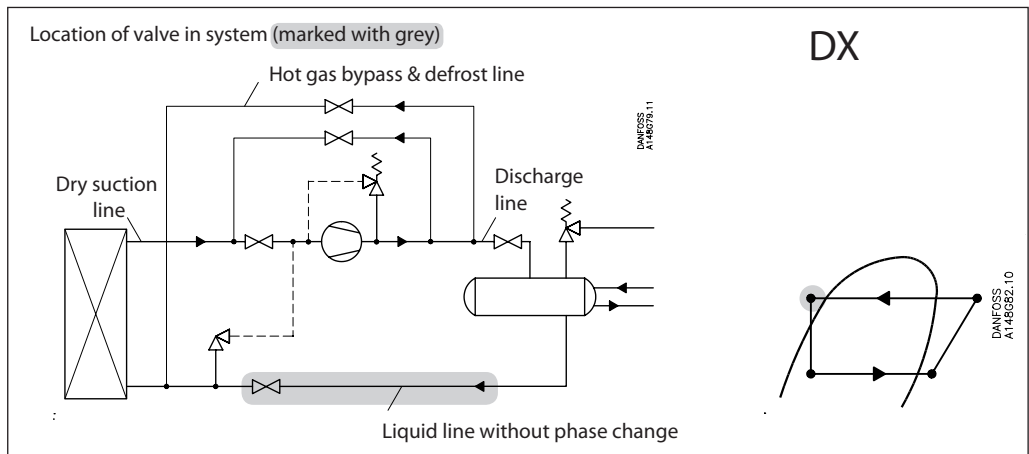
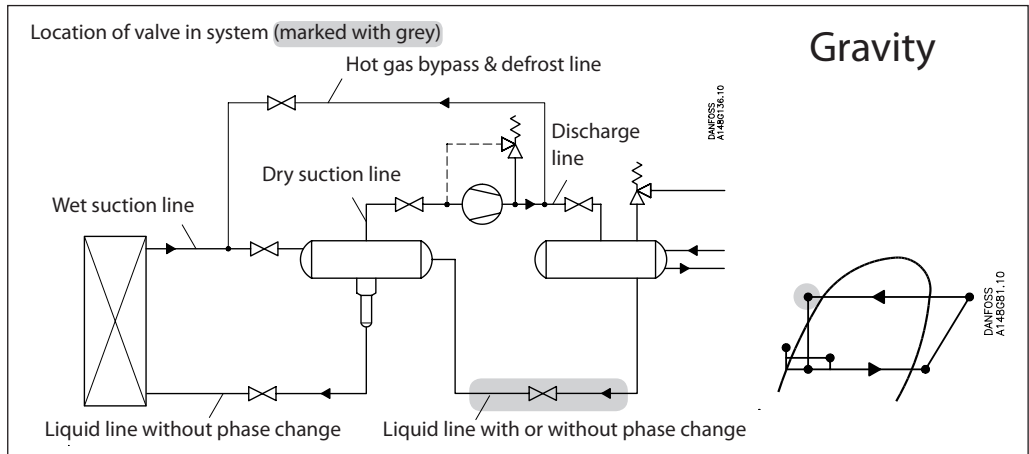
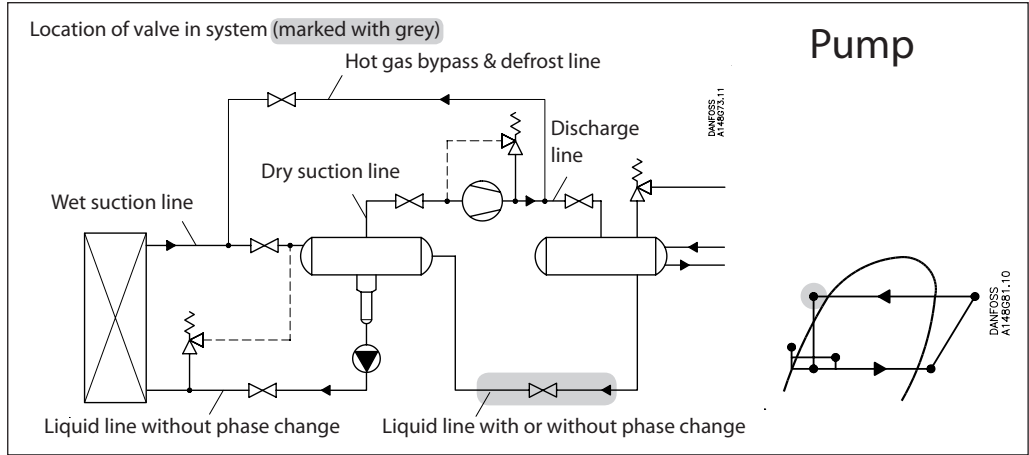

Nominal capacities

Liquid line with/without phase change

SI units

Calculation example (R 717 capacities):

Running conditions in a plant are as follows:

$$\begin{aligned} T_e &= -20\text{ C} \\ Q_o &= 250\text{ kW} \\ T_{liq} &= 10\text{ }^\circ\text{C} \\ \text{Max. } \Delta p &= 0.3\text{ bar} \end{aligned}$$

The capacity table is based on nominal condition (pressure drop $\Delta p = 0.2\text{ bar}$, $T_{liq} = 30\text{ }^\circ\text{C}$)

Therefore the actual capacity must be corrected to nominal condition by means of correction factors.

Correction factor for Δp 0.3 bar $f_{\Delta p} = 0.82$

Correction factor for liquid temperature $f_{T_{liq}} = 0.92$

$$Q_n = Q_o \times f_{\Delta p} \times f_{T_{liq}} = 250 \times 0.82 \times 0.92 = 189\text{ kW}$$

From the capacity table a ICS 25-10 with Q_n capacity 366 kW is selected.

US units

Calculation example (R 717 capacities):

Running conditions in a plant are as follows:

$$\begin{aligned} T_e &= -20\text{ }^\circ\text{F} \\ Q_o &= 130\text{ TR} \\ \text{Liquid temperature} &= 50\text{ }^\circ\text{F} \\ \text{Max. } \Delta p &= 4\text{ psi} \end{aligned}$$

The capacity table is based on nominal condition (pressure drop $\Delta p = 3\text{ psi}$, $T_{liq} = 90\text{ }^\circ\text{F}$)

Therefore the actual capacity must be corrected to nominal condition by means of correction factors.

Correction factor for Δp 4 psi, $f_{\Delta p} = 0.87$

Correction factor for liquid temperature $f_{T_{liq}} = 0.92$

$$Q_n = Q_o \times f_{\Delta p} \times f_{T_{liq}} = 130 \times 0.87 \times 0.92 = 104\text{ TR}$$

From the capacity table a ICS25-15 with Q_n capacity 175 TR is selected.

Nominal capacities

Liquid line with/without phase change

SI units

Capacity table for nominal conditions, Q_N [kW],
 $T_{liq} = 30^\circ\text{C}$,
 $\Delta P = 0.2$ bar

R 717

Type	Valve body size	K_v (m ³ /h)	Evaporating temperature [°C]						
			-50	-40	-30	-20	-10	0	10
ICS25-5	25	1.7	169	171	174	176	178	180	181
ICS25-10		3.5	347	353	358	362	366	370	372
ICS25-15		6	595	604	613	621	628	633	638
ICS25-20		8	794	806	818	828	838	845	852
ICS25-25		11.5	1140	1158	1175	1190	1203	1216	1223
ICS32	32	17	1687	1710	1738	1760	1777	1795	1810
ICS40	40	27	2675	2720	2760	2795	2825	2850	2875
ICS50	50	44	4365	4430	4500	4550	4600	4650	4685
ICS65	65	70	6940	7050	7150	7250	7325	7400	7450
ICS80	80	85	8432	8559	8690	8797	8893	8982	9046
ICS100	100	142	14086	14299	14517	14696	14857	15005	15112
ICS125	125	207	20533	20845	21162	21424	21658	21873	22029
ICS150	150	354	35115	35647	36191	36638	37038	37406	37673

Correction factor for ΔP ($f_{\Delta P}$)

ΔP (bar)	Correction factor
0.2	1.00
0.25	0.89
0.3	0.82
0.4	0.71
0.5	0.63
0.6	0.58

Correction factor for liquid temperature (T_{liq})

Liquid temperature	Correction factor
-20°C	0.82
-10°C	0.86
0°C	0.88
10°C	0.92
20°C	0.96
30°C	1.00
40°C	1.04
50°C	1.09

US units

Capacity table for nominal conditions, Q_N [Tons of Refrigeration],
 $T_{liq} = 90^\circ\text{F}$,
 $\Delta P = 3$ psi

R 717

Type	Valve body size	C_v (USgal/min)	Evaporating temperature [°F]						
			-60°F	-40°F	-20°F	0°F	20°F	40°F	60°F
ICS25-5	25	2	48.0	48.8	49.6	50.6	51.0	51.4	52.0
ICS25-10		4.1	99.0	100	102	104	105	106	107
ICS25-15		7	169	172	175	178	180	181	183
ICS25-20		9.3	226	230	233	237	240	242	244
ICS25-25		13.3	324	330	335	341	345	348	351
ICS32	32	20	480	488	496	503	509	514	518
ICS40	40	31	762	775	788	799	808	816	822
ICS50	50	51	1242	1262	1285	1302	1317	1330	1340
ICS65	65	81	1975	2010	2043	2070	2095	2115	2130
ICS80	80	98	2377	2416	2456	2496	2524	2546	2568
ICS100	100	165	4002	4068	4135	4202	4249	4287	4324
ICS125	125	240	5820	5916	6015	6113	6181	6235	6289
ICS150	150	410	9943	10107	10275	10443	10559	10651	10745

Correction factor for ΔP ($f_{\Delta P}$)

ΔP (psi)	Correction factor
3	1.00
4	0.87
5	0.79
6	0.72
7	0.66
8	0.62

Correction factor for liquid temperature (T_{liq})

Liquid temperature	Correction factor
-10°F	0.82
10°F	0.85
30°F	0.88
50°F	0.92
70°F	0.96
90°F	1.00
110°F	1.04
130°F	1.09

Nominal capacities

Liquid line with/without phase change

SI units

Capacity table for nominal conditions, Q_N [kW],
 $T_{liq} = 10^\circ\text{C}$,
 $\Delta P = 0.2 \text{ bar}$

R 744

Type	Valve body size	K _v (m ³ /h)	Evaporating temperature [°C]						
			-40	-30	-20	-10	0	10	10
ICS25-5	25	1.7	41.0	41.0	41.0	41.0	41.0	40.0	39.0
ICS25-10		3.5	84.0	85.0	85.0	85.0	85.0	83.0	80.0
ICS25-15		6	144	145	146	146	145	142	137
ICS25-20		8	193	194	195	195	194	190	183
ICS25-25		11.5	277	278	280	281	278	273	263
ICS32	32	17	409	412	415	415	411	403	388
ICS40	40	27	650	654	658	659	654	641	617
ICS50	50	44	1058	1065	1073	1073	1065	1044	1005
ICS65	65	70	1685	1695	1707	1708	1694	1661	1598
ICS80	80	85	2045	2058	2068	2070	2057	2015	1943
ICS100	100	142	3417	3438	3456	3458	3436	3365	3246
ICS125	125	207	4981	5011	5037	5040	5009	4906	4732
ICS150	150	354	8519	8570	8615	8620	8567	8390	8092

Correction factor for ΔP ($f_{\Delta P}$)

ΔP (bar)	Correction factor
0.2	1.00
0.25	0.89
0.3	0.82
0.4	0.71
0.5	0.63
0.6	0.58

Correction factor for liquid temperature (T_{liq})

Liquid temperature	Correction factor
-20°C	0.52
-10°C	0.67
0°C	0.91
10°C	1.00
15°C	1.09

US units

Capacity table for nominal conditions, Q_N [Tons of Refrigeration],
 $T_{liq} = 50^\circ\text{F}$,
 $\Delta P = 3 \text{ psi}$

R 744

Type	Valve body size	C _v (USgal/min)	Evaporating temperature [°F]						
			-60°F	-40°F	-20°F	0°F	20°F	40°F	60°F
ICS25-5	25	2	11.7	11.9	12.0	12.0	11.9	11.6	10.9
ICS25-10		4.1	24.2	24.6	24.8	24.8	24.5	23.8	22.4
ICS25-15		7	41.5	42.1	42.5	42.5	42.0	40.8	38.4
ICS25-20		9.3	55.3	56.2	56.7	56.7	56.0	54.4	51.0
ICS25-25		13.3	79.5	81.8	81.5	81.5	80.5	78.0	73.5
ICS32	32	20	118	119	120	120	119	115	109
ICS40	40	31	187	190	191	191	189	184	173
ICS50	50	51	304	309	312	312	308	299	281
ICS65	65	81	484	492	496	496	490	476	448
ICS80	80	98	582	592	596	596	589	572	539
ICS100	100	165	980	997	1004	1004	992	964	907
ICS125	125	240	1426	1450	1460	1460	1444	1402	1319
ICS150	150	410	2436	2477	2494	2494	2466	2395	2254

Correction factor for ΔP ($f_{\Delta P}$)

ΔP (psi)	Correction factor
3	1.00
4	0.87
5	0.79
6	0.72
7	0.66
8	0.62

Correction factor for liquid temperature (T_{liq})

Liquid temperature	Correction factor
-10°F	0.48
10°F	0.64
30°F	0.88
50°F	1.00

Nominal capacities

Liquid line with/without phase change

SI units

Capacity table for nominal conditions, Q_N [kW],
 $T_{liq} = 30^\circ\text{C}$,
 $\Delta P = 0.2$ bar

R 134a

Type	Valve body size	K_v (m^3/h)	Evaporating temperature [$^\circ\text{C}$]						
			-40	-30	-20	-10	0	10	20
ICS25-5	25	1.7	30.0	32.0	33.0	34.0	36.0	37.0	38.0
ICS25-10		3.5	62.0	65.0	68.0	71.0	74.0	77.0	79.0
ICS25-15		6	107	112	117	122	127	131	136
ICS25-20		8	142	149	156	162.5	169	175	181
ICS25-25		11.5	205	214	224	233	243	251	260
ICS32	32	17	303	317	331	345	358	372	384
ICS40	40	27	481	503	526	548	569	590	610
ICS50	50	44	783	820	857	893	928	962	994
ICS65	65	70	1246	1305	1363	1420	1476	1530	1582
ICS80	80	85	1511	1585	1655	1722	1795	1858	1919
ICS100	100	142	2525	2648	2765	2877	2999	3104	3206
ICS125	125	207	3680	3861	4030	4194	4371	4525	4674
ICS150	150	354	6294	6602	6892	7173	7475	7739	7992

Correction factor for ΔP ($f_{\Delta P}$)

ΔP (bar)	Correction factor
0.2	1.00
0.25	0.89
0.3	0.82
0.4	0.71
0.5	0.63
0.6	0.58

Correction factor for liquid temperature (T_{liq})

Liquid temperature	Correction factor
-20 $^\circ\text{C}$	0.66
-10 $^\circ\text{C}$	0.70
0 $^\circ\text{C}$	0.76
10 $^\circ\text{C}$	0.82
20 $^\circ\text{C}$	0.90
30$^\circ\text{C}$	1.00
40 $^\circ\text{C}$	1.13
50 $^\circ\text{C}$	1.29

US units

Capacity table for nominal conditions, Q_N [Tons of Refrigeration],
 $T_{liq} = 90^\circ\text{F}$,
 $\Delta P = 3$ psi

R 134a

Type	Valve body size	C_v (USgal/min)	Evaporating temperature [$^\circ\text{F}$]						
			-40 $^\circ\text{F}$	-20 $^\circ\text{F}$	0 $^\circ\text{F}$	20 $^\circ\text{F}$	40 $^\circ\text{F}$	60 $^\circ\text{F}$	80 $^\circ\text{F}$
ICS25-5	25	2	8.5	9.0	9.4	9.8	10.3	10.7	11.1
ICS25-10		4.1	17.5	18.4	19.4	20.3	21.2	22.0	22.8
ICS25-15		7	30.0	31.6	33.2	34.7	36.2	37.7	39.0
ICS25-20		9.3	40.0	42.1	44.3	46.3	48.4	50.3	52.0
ICS25-25		13.3	57.4	60.6	63.6	66.5	69.5	72.3	75.0
ICS32	32	20	85	89	94	98.5	103	107	111
ICS40	40	31	135	142	149	156	163	170	176
ICS50	50	51	220	232	244	255	266	277	287
ICS65	65	81	350	369	387	405	423	440	456
ICS80	80	98	421	443	466	487	509	530	549
ICS100	100	165	709	747	784	820	857	892	924
ICS125	125	240	1031	1086	1141	1193	1247	1297	1344
ICS150	150	410	1761	1855	1949	2038	2131	2216	2296

Correction factor for ΔP ($f_{\Delta P}$)

ΔP (psi)	Correction factor
3	1.00
4	0.87
5	0.79
6	0.72
7	0.66
8	0.62

Correction factor for liquid temperature (T_{liq})

Liquid temperature	Correction factor
-10 $^\circ\text{F}$	0.64
10 $^\circ\text{F}$	0.68
30 $^\circ\text{F}$	0.74
50 $^\circ\text{F}$	0.81
70 $^\circ\text{F}$	0.89
90$^\circ\text{F}$	1.00
110 $^\circ\text{F}$	1.15
130 $^\circ\text{F}$	1.35

Nominal capacities

Liquid line with/without phase change

SI units

Capacity table for nominal conditions, Q_N [kW],
 $T_{liq} = 30^\circ\text{C}$,
 $\Delta P = 0.2$ bar

R 404A

Type	Valve body size	K_v (m^3/h)	Evaporating temperature [$^\circ\text{C}$]						
			-50	-40	-30	-20	-10	0	10
ICS25-5	25	1.7	19.6	21.0	22.3	23.7	25.0	26.1	27.3
ICS25-10		3.5	40.3	43.0	46.0	49.0	51.3	54.0	56.0
ICS25-15		6	69.0	74.0	79.0	84.0	88.0	92.0	96.0
ICS25-20		8	92.0	99.0	105	111	117	123	128
ICS25-25		11.5	133	142	151	160	169	177	185
ICS32	32	17	196	210	223	237	249	261	274
ICS40	40	27	311	333	354	375	396	415	432
ICS50	50	44	507	542	577	612	645	676	705
ICS65	65	70	806	863	918	973	1025	1077	1120
ICS80	80	85	979	1049	1116	1184	1246	1307	1363
ICS100	100	142	1636	1752	1864	1978	2082	2183	2277
ICS125	125	207	2385	2554	2717	2883	3035	3182	3319
ICS150	150	354	4079	4367	4647	4931	5191	5442	5675

Correction factor for ΔP ($f_{\Delta P}$)

ΔP (bar)	Correction factor
0.2	1.00
0.25	0.89
0.3	0.82
0.4	0.71
0.5	0.63
0.6	0.58

Correction factor for liquid temperature (T_{liq})

Liquid temperature	Correction factor
-20 $^\circ\text{C}$	0.55
-10 $^\circ\text{C}$	0.60
0 $^\circ\text{C}$	0.66
10 $^\circ\text{C}$	0.74
20 $^\circ\text{C}$	0.85
30$^\circ\text{C}$	1.00
40 $^\circ\text{C}$	1.23
50 $^\circ\text{C}$	1.68

US units

Capacity table for nominal conditions, Q_N [Tons of Refrigeration],
 $T_{liq} = 90^\circ\text{F}$,
 $\Delta P = 3$ psi

R 404A

Type	Valve body size	C_v (USgal/min)	Evaporating temperature [$^\circ\text{F}$]						
			-60 $^\circ\text{F}$	-40 $^\circ\text{F}$	-20 $^\circ\text{F}$	0 $^\circ\text{F}$	20 $^\circ\text{F}$	40 $^\circ\text{F}$	60 $^\circ\text{F}$
ICS25-5	25	2	5.4	5.8	6.2	6.6	7.0	7.4	7.8
ICS25-10		4.1	11.0	11.9	12.8	13.7	14.5	15.3	16.0
ICS25-15		7	18.9	20.4	22.0	23.4	24.9	26.2	27.4
ICS25-20		9.3	25.2	27.2	29.2	31.3	33.0	35.0	36.5
ICS25-25		13.3	36.1	39.1	42.0	45.0	47.6	50.0	52.5
ICS32	32	20	53.5	57.8	62.0	66.4	70.4	74.0	77.6
ICS40	40	31	85.0	92.0	99.0	106	112	118	123
ICS50	50	51	138	150	161	172	182	192	201
ICS65	65	81	220	238	256	274	290	306	320
ICS80	80	98	265	287	308	329	348	367	385
ICS100	100	165	446	483	518	554	587	619	648
ICS125	125	240	649	702	754	806	853	900	942
ICS150	150	410	1109	1199	1288	1377	1458	1537	1609

Correction factor for ΔP ($f_{\Delta P}$)

ΔP (psi)	Correction factor
3	1.00
4	0.87
5	0.79
6	0.72
7	0.66
8	0.62

Correction factor for liquid temperature (T_{liq})

Liquid temperature	Correction factor
-10 $^\circ\text{F}$	0.52
10 $^\circ\text{F}$	0.57
30 $^\circ\text{F}$	0.63
50 $^\circ\text{F}$	0.72
70 $^\circ\text{F}$	0.83
90$^\circ\text{F}$	1.00
110 $^\circ\text{F}$	1.29
130 $^\circ\text{F}$	1.92

Nominal capacities

SI units

Capacity table for nominal conditions, Q_N [kW],
 $T_{liq} = 30^\circ\text{C}$,
 $\Delta P = 0.2$ bar

R 22

Liquid line with/without phase change

Type	Valve body size	K_v (m ³ /h)	Evaporating temperature [°C]						
			-50	-40	-30	-20	-10	0	10
ICS25-5	25	1.7	33.7	34.8	35.8	36.8	37.8	38.6	39.4
ICS25-10		3.5	69.3	71.7	73.8	75.8	77.8	79.6	81.2
ICS25-15		6	119	123	127	130	133	136	139
ICS25-20		8	158	164	169	173	178	182	186
ICS25-25		11.5	228	235	242	249	255	261	267
ICS32	32	17	337	348	358	368	378	386	394
ICS40	40	27	535	553	569	585	600	614	626
ICS50	50	44	871	901	928	953	977	1000	1021
ICS65	65	70	1386	1433	1476	1516	1555	1591	1624
ICS80	80	85	1684	1741	1792	1841	1888	1931	1972
ICS100	100	142	2813	2908	2994	3075	3154	3226	3294
ICS125	125	207	4100	4239	4365	4482	4598	4703	4802
ICS150	150	354	7012	7249	7465	7665	7864	8042	8212

Correction factor for ΔP ($f^{\Delta P}$)

ΔP (bar)	Correction factor
0.2	1.00
0.25	0.89
0.3	0.82
0.4	0.71
0.5	0.63
0.6	0.58

Correction factor for liquid temperature (T_{liq})

Liquid temperature	Correction factor
-20°C	0.71
-10°C	0.75
0°C	0.80
10°C	0.86
20°C	0.92
30°C	1.00
40°C	1.09
50°C	1.22

US units

Capacity table for nominal conditions, Q_N [Tons of Refrigeration],
 $T_{liq} = 90^\circ\text{F}$,
 $\Delta P = 3$ psi

R 22

Type	Valve body size	C_v (USgal/min)	Evaporating temperature [°F]						
			-60°F	-40°F	-20°F	0°F	20°F	40°F	60°F
ICS25-5	25	2	9.5	9.8	10.1	10.5	10.7	11.0	11.3
ICS25-10		4.1	19.5	20.2	20.9	21.5	22.1	22.7	23.2
ICS25-15		7	33.5	34.6	35.9	37.0	38.0	39.0	39.8
ICS25-20		9.3	44.5	46.2	47.8	49.2	50.6	52.0	53.0
ICS25-25		13.3	64.0	66.4	68.6	71.0	73.0	75.0	76.0
ICS32	32	20	95.0	98.0	101	105	108	110	112
ICS40	40	31	151	156	161	166	171	175	179
ICS50	50	51	245	254	263	271	279	285	291
ICS65	65	81	390	404	418	431	443	454	464
ICS80	80	98	470	486	502	519	533	546	558
ICS100	100	165	791	818	846	874	897	920	939
ICS125	125	240	1150	1190	1230	1271	1305	1338	1366
ICS150	150	410	1965	2033	2102	2171	2230	2286	2333

Correction factor for ΔP ($f^{\Delta P}$)

ΔP (psi)	Correction factor
3	1.00
4	0.87
5	0.79
6	0.72
7	0.66
8	0.62

Correction factor for liquid temperature (T_{liq})

Liquid temperature	Correction factor
-10°F	0.73
10°F	0.77
30°F	0.82
50°F	0.87
70°F	0.93
90°F	1.00
110°F	1.09
130°F	1.20

Nominal capacities

Liquid line without phase change

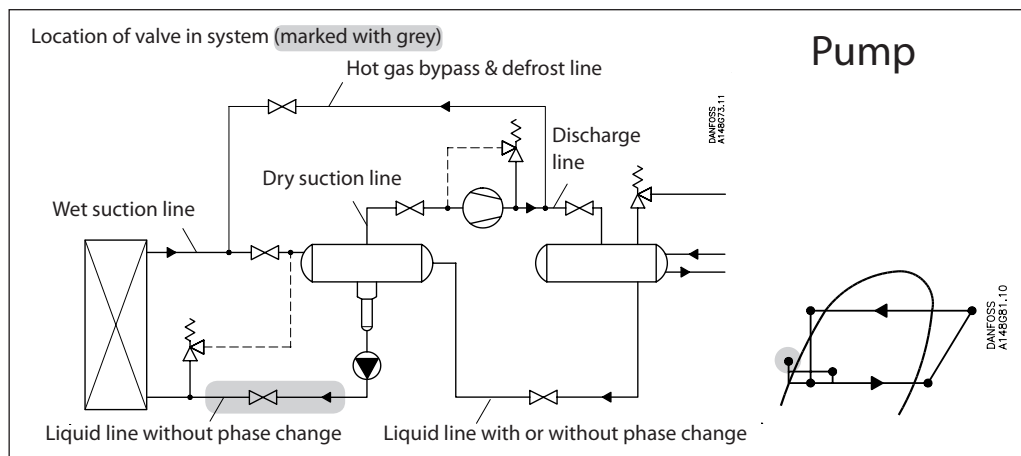

SI units

Calculation example (R 717 capacities):

Running conditions in a plant are as follows:

- $T_e = -20\text{ C}$
- $Q_o = 180\text{ kW}$
- Circulation rate = 3
- Max. $\Delta p = 0.3\text{ bar}$

The capacity table is based on nominal condition (pressure drop $\Delta p = 0.2\text{ bar}$, circulation rate = 4)

Therefore the actual capacity must be corrected to nominal condition by means of correction factors.

Correction factor for $\Delta p\ 0.3\text{ bar } f_{\Delta p} = 0.82$
 Correction factor for circulation rate $f_{rec} = 0.75$

$$Q_n = Q_o \times f_{\Delta p} \times f_{rec} = 180 \times 0.82 \times 0.75 = 111\text{ kW}$$

From the capacity table a ICS 25-10 with Q_n capacity 117 kW is selected.

US units

Calculation example (R 717 capacities):

Running conditions in a plant are as follows:

- $T_e = -20\text{ F}$
- $Q_o = 130\text{ TR}$
- Circulation rate = 3
- Max. $\Delta p = 4\text{ psi}$

The capacity table is based on nominal condition (pressure drop $\Delta p = 3\text{ psi}$, circulation rate = 4)

Therefore the actual capacity must be corrected to nominal condition by means of correction factors.

Correction factor for $\Delta p\ 4\text{ psi } f_{\Delta p} = 0.87$
 Correction factor for circulation rate $f_{rec} = 0.75$

$$Q_n = Q_o \times f_{\Delta p} \times f_{rec} = 130 \times 0.87 \times 0.75 = 85\text{ TR}$$

From the capacity table a ICS 25 with Q_n capacity 114 TR is selected.

Nominal capacities

Liquid line without phase change

SI units

Capacity table for nominal conditions, Q_N [kW], circulation rate = 4, $\Delta P = 0.2$ bar

R 717

Type	Valve body size	K_v (m ³ /h)	Evaporating temperature [°C]							
			-50	-40	-30	-20	-10	0	10	20
ICS25-5	25	1.7	63.0	61.0	59.0	56.6	55.0	52.5	50.3	48.0
ICS25-10		3.5	128	124	121	117	112	108	104	99.0
ICS25-15		6	219	213	207	200	193	185	178	169
ICS25-20		8	292	284	276	266	257	247	237	226
ICS25-25		11.5	419	408	396	383	369	355	340	325
ICS32	32	17	620	603	585	566	546	525	503	480
ICS40	40	27	985	959	930	900	868	833	798	761
ICS50	50	44	1605	1560	1515	1465	1413	1360	1300	1242
ICS65	65	70	2550	2485	2410	2330	2248	2160	2070	1976
ICS80	80	85	3106	3020	2932	2832	2732	2624	2516	2400
ICS100	100	142	5190	5045	4898	4730	4563	4383	4204	4009
ICS125	125	207	7565	7354	7140	6896	6652	6390	6128	5844
ICS150	150	354	12938	12576	12210	11793	11376	10928	10479	9994

Correction factor for ΔP ($f_{\Delta P}$)

ΔP (bar)	Correction factor
0.2	1.00
0.25	0.89
0.3	0.82
0.4	0.71
0.5	0.63
0.6	0.58

Correction factor for circulation rate (f_{rec})

Circulation rate	Correction factor
2	0.5
3	0.75
4	1
6	1.5
8	2
10	2.5

US units

Capacity table for nominal conditions, Q_N [Tons of Refrigeration], circulation rate = 4, $\Delta P = 3$ psi

R 717

Type	Valve body size	C_v (USgal/min)	Evaporating temperature [°F]							
			-60°F	-40°F	-20°F	0°F	20°F	40°F	60°F	80°F
ICS25-5	25	2	18.0	17.4	16.9	16.2	15.6	14.9	14.2	13.4
ICS25-10		4.1	37.0	35.9	34.7	33.4	32.0	30.6	29.6	27.6
ICS25-15		7	63.4	61.5	59.4	57.3	55.0	52.5	50.0	47.3
ICS25-20		9.3	84.5	82.0	79.3	76.3	73.3	70.0	66.6	63.0
ICS25-25		13.3	122	118	114	110	105	102	95.7	91.0
ICS32	32	20	180	174	169	162	156	149	142	134
ICS40	40	31	285	276	267	258	247	236	225	213
ICS50	50	51	465	451	436	420	403	385	366	347
ICS65	65	81	740	717	694	668	641	613	583	552
ICS80	80	98	891	863	835	804	771	738	703	664
ICS100	100	165	1499	1453	1406	1353	1298	1243	1183	1118
ICS125	125	240	2181	2113	2045	1968	1889	1808	1721	1627
ICS150	150	410	3726	3609	3493	3363	3226	3088	2941	2779

Correction factor for ΔP ($f_{\Delta P}$)

ΔP (psi)	Correction factor
3	1.00
4	0.87
5	0.79
6	0.72
7	0.66
8	0.62

Correction factor for circulation rate (f_{rec})

Circulation rate	Correction factor
2	0.5
3	0.75
4	1
6	1.5
8	2
10	2.5

Nominal capacities

Liquid line without phase change

SI units

Capacity table for nominal conditions, Q_N [kW], circulation rate = 4, $\Delta P = 0.2$ bar

R 744

Type	Valve body size	K_v (m ³ /h)	Evaporating temperature [°C]							
			-50	-40	-30	-20	-10	0	10	20
ICS25-5	25	1.7	19.0	18.0	16.6	15.2	13.6	12.0	9.8	7.1
ICS25-10		3.5	39.3	37.0	34.2	31.3	28.0	24.4	20.0	14.7
ICS25-15		6	68.0	63.0	59.0	54.0	48.0	42.0	36.0	25.0
ICS25-20		8	90.0	85.0	78.0	72.0	64.0	56.0	46.0	34.0
ICS25-25		11.5	129	121	112	103	92.0	80.0	66.0	48.0
ICS32	32	17	191	179	166	152	136	118	98	72
ICS40	40	27	303	285	264	241	216	188	155	113
ICS50	50	44	494	464	430	393	352	306	252	185
ICS65	65	70	787	738	685	626	560	487	401	294
ICS80	80	85	955	897	831	761	680	593	490	357
ICS100	100	142	1596	1499	1388	1271	1136	991	819	596
ICS125	125	207	2326	2185	2023	1853	1656	1444	1194	869
ICS150	150	354	3978	3736	3460	3170	2832	2470	2043	1486

Correction factor for ΔP ($f_{\Delta P}$)

ΔP (bar)	Correction factor
0.2	1.00
0.25	0.89
0.3	0.82
0.4	0.71
0.5	0.63
0.6	0.58

Correction factor for circulation rate (f_{rec})

Circulation rate	Correction factor
2	0.5
3	0.75
4	1
6	1.5
8	2
10	2.5

US units

Capacity table for nominal conditions, Q_N [Tons of Refrigeration], circulation rate = 4, $\Delta P = 3$ psi

R 744

Type	Valve body size	C_v (USgal/min)	Evaporating temperature [°F]							
			-60°F	-40°F	-20°F	0°F	20°F	40°F	60°F	80°F
ICS25-5	25	2	5.6	5.8	4.8	4.3	3.8	3.2	2.4	1.4
ICS25-10		4.1	11.4	10.7	9.8	8.8	7.8	6.5	5.0	2.8
ICS25-15		7	19.6	18.3	16.8	15.2	13.3	11.2	8.6	4.8
ICS25-20		9.3	26.1	24.4	22.4	20.2	17.7	14.9	11.4	6.3
ICS25-25		13.3	37.6	35.0	32.2	29.0	25.5	21.4	16.4	9.1
ICS32	32	20	55.5	51.8	47.6	43.0	37.7	31.6	24.2	13.5
ICS40	40	31	88.0	82.0	75.5	68.0	60.0	50.2	38.5	21.4
ICS50	50	51	144	134	123	111	98.0	82.0	62.7	35.0
ICS65	65	81	229	213	196	177	155	130	100	55.4
ICS80	80	98	275	260	236	213	187	157	120	67
ICS100	100	165	463	438	397	358	315	264	202	113
ICS125	125	240	674	637	578	521	458	384	294	164
ICS150	150	410	1152	1087	987	889	783	656	502	281

Correction factor for ΔP ($f_{\Delta P}$)

ΔP (psi)	Correction factor
3	1.00
4	0.87
5	0.79
6	0.72
7	0.66
8	0.62

Correction factor for circulation rate (f_{rec})

Circulation rate	Correction factor
2	0.5
3	0.75
4	1
6	1.5
8	2
10	2.5

Nominal capacities

Liquid line without phase change

SI units

Capacity table for nominal conditions, Q_N [kW], circulation rate = 4, $\Delta P = 0.2$ bar

R 134a

Type	Valve body size	K_v (m ³ /h)	Evaporating temperature [°C]						
			-40	-30	-20	-10	0	10	20
ICS25-5	25	1.7	14.0	13.5	13.0	12.4	11.9	11.2	10.6
ICS25-10		3.5	28.9	27.8	26.8	25.6	24.4	23.2	21.8
ICS25-15		6	49.5	47.7	45.9	43.9	41.8	39.7	37.4
ICS25-20		8	65.9	63.5	61.1	58.5	55.8	52.9	49.8
ICS25-25		11.5	94.8	91.3	87.9	84.1	80.2	76.1	71.6
ICS32	32	17	140	135	130	124	119	112	106
ICS40	40	27	223	214	206	197	188	179	168
ICS50	50	44	363	349	336	322	307	291	274
ICS65	65	70	577	556	535	512	488	463	436
ICS80	80	85	701	675	650	621	593	562	529
ICS100	100	142	1171	1127	1085	1038	991	939	885
ICS125	125	207	1707	1643	1582	1513	1444	1369	1289
ICS150	150	354	2919	2810	2706	2587	2470	2341	2205

Correction factor for ΔP ($f_{\Delta P}$)

ΔP (bar)	Correction factor
0.2	1.00
0.25	0.89
0.3	0.82
0.4	0.71
0.5	0.63
0.6	0.58

Correction factor for circulation rate (f_{rec})

Circulation rate	Correction factor
2	0.5
3	0.75
4	1
6	1.5
8	2
10	2.5

US units

Capacity table for nominal conditions, Q_N [Tons of Refrigeration], circulation rate = 4, $\Delta P = 3$ psi

R 134a

Type	Valve body size	C_v (USgal/min)	Evaporating temperature [°F]						
			-40°F	-20°F	0°F	20°F	40°F	60°F	80°F
ICS25-5	25	2	4.1	4.0	3.8	3.6	3.4	3.2	3.0
ICS25-10		4.1	8.5	8.1	7.7	7.4	7.0	6.6	6.1
ICS25-15		7	14.4	13.8	13.2	12.6	11.9	11.2	10.4
ICS25-20		9.3	19.2	18.4	17.6	16.7	15.8	14.9	13.8
ICS25-25		13.3	27.4	26.3	25.1	23.9	22.7	21.3	19.8
ICS32	32	20	41.2	39.5	37.8	35.9	34.1	32.0	29.8
ICS40	40	31	63.9	61.2	58.6	55.7	52.8	49.6	46.1
ICS50	50	51	105	101	96.3	91.6	86.9	81.5	75.9
ICS65	65	81	167	160	153	146	138	130	121
ICS80	80	98	202	194	185	176	167	157	146
ICS100	100	165	340	326	312	297	281	264	246
ICS125	125	240	495	475	453	432	409	384	357
ICS150	150	410	845	811	774	737	698	657	611

Correction factor for ΔP ($f_{\Delta P}$)

ΔP (psi)	Correction factor
3	1.00
4	0.87
5	0.79
6	0.72
7	0.66
8	0.62

Correction factor for circulation rate (f_{rec})

Circulation rate	Correction factor
2	0.5
3	0.75
4	1
6	1.5
8	2
10	2.5

Nominal capacities

Liquid line without phase change

SI units

Capacity table for nominal conditions, Q_N [kW], circulation rate = 4, $\Delta P = 0.2$ bar

R 404A

Type	Valve body size	K_v (m ³ /h)	Evaporating temperature [°C]							
			-50	-40	-30	-20	-10	0	10	20
ICS25-5	25	1.7	12.4	12.0	11.3	10.7	10.0	9.5	9.0	8.1
ICS25-10		3.5	25.4	24.4	23.2	22.0	21.0	19.7	18.2	17.0
ICS25-15		6	44.0	42.0	40.0	38.0	36.0	34.0	31.0	29.0
ICS25-20		8	58.0	56.0	53.0	51.0	48.0	45.0	42.0	38.0
ICS25-25		11.5	84.0	80.0	76.0	73.0	69.0	65.0	60.0	55.0
ICS32	32	17	124	119	113	107	102	95.0	89.0	81.0
ICS40	40	27	196	189	179	170	161	151	141	129
ICS50	50	44	320	307	291	277	263	247	229	210
ICS65	65	70	509	488	463	441	418	393	365	334
ICS80	80	85	619	594	564	537	508	478	444	407
ICS100	100	142	1034	993	942	897	849	798	742	680
ICS125	125	207	1507	1448	1373	1307	1237	1163	1081	991
ICS150	150	354	2578	2475	2347	2235	2116	1989	1849	1694

Correction factor for ΔP ($f_{\Delta P}$)

ΔP (bar)	Correction factor
0.2	1.00
0.25	0.89
0.3	0.82
0.4	0.71
0.5	0.63
0.6	0.58

Correction factor for circulation rate (f_{rec})

Circulation rate	Correction factor
2	0.5
3	0.75
4	1
6	1.5
8	2
10	2.5

US units

Capacity table for nominal conditions, Q_N [Tons of Refrigeration], circulation rate = 4, $\Delta P = 3$ psi

R 404A

Type	Valve body size	C_v (USgal/min)	Evaporating temperature [°F]							
			-60°F	-40°F	-20°F	0°F	20°F	40°F	60°F	80°F
ICS25-5	25	2	3.6	3.5	3.2	3.0	2.9	2.7	2.4	2.2
ICS25-10		4.1	7.4	7.0	6.7	6.3	5.9	5.5	5.0	4.5
ICS25-15		7	12.5	12.1	11.4	10.8	10.1	9.4	8.6	7.7
ICS25-20		9.3	16.9	16.1	15.2	14.4	13.5	12.6	11.5	10.3
ICS25-25		13.3	24.2	23.2	21.9	20.7	19.4	18.0	16.5	14.7
ICS32	32	20	35.8	34.2	32.3	30.6	28.8	26.7	24.4	21.8
ICS40	40	31	57.0	54.4	51.3	48.6	45.6	42.5	38.8	34.6
ICS50	50	51	93.0	88.6	84.0	79.0	74.4	69.0	63.0	56.5
ICS65	65	81	147	141	133	126	118	110	101	90.0
ICS80	80	98	177	170	160	151	142	132	121	108
ICS100	100	165	299	286	270	255	240	223	203	182
ICS125	125	240	435	416	392	370	348	324	295	265
ICS150	150	410	742	711	670	633	595	554	505	453

Correction factor for ΔP ($f_{\Delta P}$)

ΔP (psi)	Correction factor
3	1.00
4	0.87
5	0.79
6	0.72
7	0.66
8	0.62

Correction factor for circulation rate (f_{rec})

Circulation rate	Correction factor
2	0.5
3	0.75
4	1
6	1.5
8	2
10	2.5

Nominal capacities

Liquid line without phase change

SI units

Capacity table for nominal conditions, Q_N [kW], circulation rate = 4, $\Delta P = 0.2$ bar

R 22

Type	Valve body size	K_v (m ³ /h)	Evaporating temperature [°C]							
			-50	-40	-30	-20	-10	0	10	20
ICS25-5	25	1.7	15.1	14.6	14.1	13.5	12.9	12.3	11.6	10.9
ICS25-10		3.5	31.2	30.1	29.0	27.9	26.6	25.3	24.0	22.5
ICS25-15		6	53.4	51.6	49.7	47.7	45.6	43.4	41.1	38.6
ICS25-20		8	71.2	68.8	66.3	63.7	60.8	57.8	54.7	51.4
ICS25-25		11.5	102	98.9	95.3	91.5	87.4	83.1	78.7	73.9
ICS32	32	17	151	146	141	135	129	123	116	109
ICS40	40	27	240	232	224	215	205	195	185	174
ICS50	50	44	392	378	365	350	334	318	301	283
ICS65	65	70	623	602	580	557	532	506	479	450
ICS80	80	85	756	731	705	676	646	614	582	546
ICS100	100	142	1263	1221	1177	1130	1079	1027	971	913
ICS125	125	207	1841	1779	1716	1647	1572	1496	1416	1330
ICS150	150	354	3148	3043	2935	2816	2689	2559	2422	2275

Correction factor for ΔP ($f_{\Delta P}$)

ΔP (bar)	Correction factor
0.2	1.00
0.25	0.89
0.3	0.82
0.4	0.71
0.5	0.63
0.6	0.58

Correction factor for circulation rate (f_{rec})

Circulation rate	Correction factor
2	0.5
3	0.75
4	1
6	1.5
8	2
10	2.5

US units

Capacity table for nominal conditions, Q_N [Tons of Refrigeration], circulation rate = 4, $\Delta P = 3$ psi

R 22

Type	Valve body size	C_v (USgal/min)	Evaporating temperature [°F]							
			-60°F	-40°F	-20°F	0°F	20°F	40°F	60°F	80°F
ICS25-5	25	2	4.4	4.2	4.1	3.9	3.7	3.5	3.2	3.0
ICS25-10		4.1	9.0	8.7	8.3	8.0	7.6	7.1	6.7	6.2
ICS25-15		7	15.5	14.9	14.3	13.6	13.0	12.2	11.5	10.6
ICS25-20		9.3	20.6	19.9	19.1	18.2	17.3	16.3	15.3	14.2
ICS25-25		13.3	29.7	28.6	27.4	26.2	24.9	23.5	22.0	20.4
ICS32	32	20	44.0	42.2	40.5	38.7	36.8	34.6	32.5	30.2
ICS40	40	31	70.0	67.0	64.3	61.4	58.3	55.0	51.6	47.8
ICS50	50	51	114	109	105	100	95.0	90.0	84.0	78.0
ICS65	65	81	181	174	167	159	151	143	134	124
ICS80	80	98	218	209	201	192	182	172	161	149
ICS100	100	165	366	352	338	323	307	289	271	251
ICS125	125	240	533	512	492	470	446	421	394	365
ICS150	150	410	910	875	841	802	763	719	673	624

Correction factor for ΔP ($f_{\Delta P}$)

ΔP (psi)	Correction factor
3	1.00
4	0.87
5	0.79
6	0.72
7	0.66
8	0.62

Correction factor for circulation rate (f_{rec})

Circulation rate	Correction factor
2	0.5
3	0.75
4	1
6	1.5
8	2
10	2.5

Nominal capacities

Wet suction line

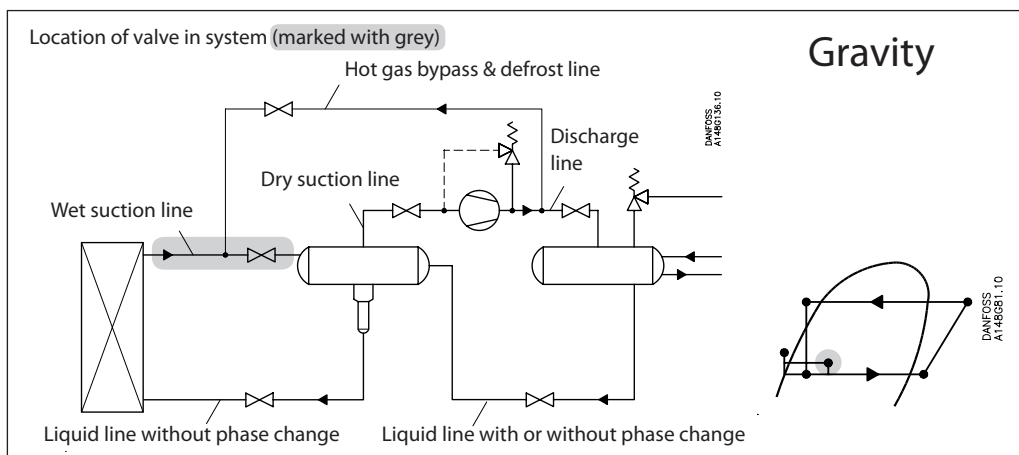
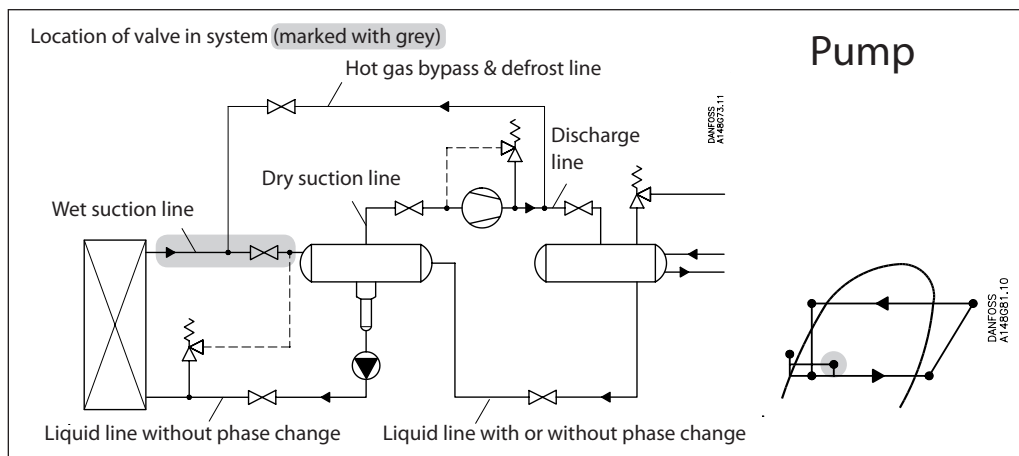

Nominal capacities

Wet suction line

SI units

Calculation example (R 717 capacities):

An application has following running conditions:

$T_e = -20\text{ C}$
 $Q_o = 80\text{ kW}$
 Circulation rate = 3
 Max. $\Delta p = 0.3\text{ bar}$

 The capacity table is based on nominal condition (pressure drop $\Delta p = 0.2\text{ bar}$, circulation rate = 4)

Therefore the actual capacity must be corrected to nominal condition by means of correction factors.

 Correction factor for $\Delta p\ 0.3\text{ bar}$ $f_{\Delta p} = 0.82$

 Correction factor for circulation rate $f_{rec} = 0.9$

$$Q_n = Q_o \times f_{\Delta p} \times f_{rec} = 80 \times 0.82 \times 0.9 = 59\text{ kW}$$

 From the capacity table a ICS 32 with Q_n capacity 60 kW is selected.

US units

Calculation example (R 717 capacities):

An application has following running conditions:

$T_e = -20\text{ F}$
 $Q_o = 8\text{ TR}$
 Circulation rate = 3
 Max. $\Delta p = 4\text{ psi}$

 The capacity table is based on nominal condition (pressure drop $\Delta p = 3\text{ psi}$, circulation rate = 4)

Therefore the actual capacity must be corrected to nominal condition by means of correction factors.

 Correction factor for $\Delta p\ 4\text{ psi}$, $f_{\Delta p} = 0.87$

 Correction factor for circulation rate $f_{rec} = 0.9$

$$Q_n = Q_o \times f_{\Delta p} \times f_{rec} = 8 \times 0.87 \times 0.9 = 6.3\text{ TR}$$

 From the capacity table a ICS 25-20 with Q_n capacity 6.8 TR is selected.

Nominal capacities

Wet suction line

SI units

Capacity table for nominal conditions, Q_N [kW], circulation rate = 4, $\Delta P = 0.2$ bar

R 717

Type	Valve body size	K_v (m ³ /h)	Evaporating temperature [°C]							
			-50	-40	-30	-20	-10	0	10	20
ICS25-5	25	1.7	2.4	3.7	4.9	6.0	7.2	8.5	9.7	11.0
ICS25-10		3.5	5.0	7.6	9.9	12.4	15.0	17.4	20.0	23.0
ICS25-15		6	8.6	13.0	17.0	21.0	25.5	30.0	34.0	39.0
ICS25-20		8	11.4	17.3	23.0	28.0	34.0	40.0	46.0	52.0
ICS25-25		11.5	18.5	25.0	33.0	41.0	49.0	57.0	66.0	75.0
ICS32	32	17	24.4	37.0	48.0	60.0	72.0	85.0	97.0	110.0
ICS40	40	27	38.7	58.0	77.0	95.0	115	134	154	176
ICS50	50	44	63.1	95	125	155	186	219	252	286
ICS65	65	70	100	152	200	247	297	348	401	455
ICS80	80	85	123	184	242	300	361	423	486	553
ICS100	100	142	206	308	405	501	603	707	812	924
ICS125	125	207	300	449	590	730	880	1031	1183	1347
ICS150	150	354	513	767	1009	1248	1504	1764	2023	2303

Correction factor for ΔP ($f_{\Delta P}$)

ΔP (bar)	Correction factor
0.2	1.00
0.25	0.89
0.3	0.82
0.4	0.71
0.5	0.63
0.6	0.58

Correction factor for circulation rate (f_{rec})

Circulation rate	Correction factor
2	0.77
3	0.90
4	1
6	1.13
8	1.20
10	1.25

US units

Capacity table for nominal conditions, Q_N [Tons of Refrigeration], circulation rate = 4, $\Delta P = 3$ psi

R 717

Type	Valve body size	C_v (USgal/min)	Evaporating temperature [°F]							
			-60°F	-40°F	-20°F	0°F	20°F	40°F	60°F	80°F
ICS25-5	25	2	0.6	1.1	1.4	1.8	2.2	2.6	3.0	3.5
ICS25-10		4.1	1.3	2.2	3.0	3.7	4.5	5.4	6.2	7.1
ICS25-15		7	2.3	3.7	5.1	6.4	7.8	9.2	10.7	12.2
ICS25-20		9.3	3.0	5.0	6.8	8.5	10.3	12.3	14.2	16.2
ICS25-25		13.3	4.4	7.1	9.7	12.2	14.9	17.6	20.4	23.3
ICS32	32	20	6.5	10.5	14.3	18.1	22.0	26.0	30.0	34.5
ICS40	40	31	10.3	16.8	22.8	28.8	35.0	41.4	48.0	55.0
ICS50	50	51	16.8	27.3	37.0	47.0	57.0	67.0	78.0	89.0
ICS65	65	81	26.8	43.5	59.0	75.0	91.0	107	124	142
ICS80	80	98	32	53	71	90	109	129	149	171
ICS100	100	165	53	88	120	151	184	217	251	288
ICS125	125	240	78	129	174	219	267	316	366	419
ICS150	150	410	133	220	297	375	456	540	625	716

Correction factor for ΔP ($f_{\Delta P}$)

ΔP (psi)	Correction factor
3	1.00
4	0.87
5	0.79
6	0.72
7	0.66
8	0.62

Correction factor for circulation rate (f_{rec})

Circulation rate	Correction factor
2	0.77
3	0.90
4	1
6	1.13
8	1.20
10	1.25

Nominal capacities

Wet suction line

SI units

Capacity table for nominal conditions, Q_N [kW], circulation rate = 4, $\Delta P = 0.2$ bar

R 744

Type	Valve body size	K_v (m ³ /h)	Evaporating temperature [°C]							
			-50	-40	-30	-20	-10	0	10	20
ICS25-5	25	1.7	5.2	6.0	6.7	7.4	8.0	8.3	8.4	7.7
ICS25-10		3.5	10.7	12.2	13.8	15.0	16.3	17.0	17.2	16.0
ICS25-15		6	18.3	21.0	23.6	26.0	28.0	29.2	29.5	27.3
ICS25-20		8	24.4	28.0	31.5	35.0	37.0	39.0	39.3	36.5
ICS25-25		11.5	35.0	40.0	45.0	50.0	54.0	56.0	56.5	52.0
ICS32	32	17	52.0	59.0	67.0	74.0	79.0	83.0	84.0	77.0
ICS40	40	27	82.0	94.0	106	117	126	132	133	123
ICS50	50	44	134	154	173	190	205	215	216	200
ICS65	65	70	213	244	275	303	326	342	344	318
ICS80	80	85	259	297	334	369	396	415	418	386
ICS100	100	142	433	496	558	616	662	693	699	645
ICS125	125	207	631	723	814	898	966	1010	1019	941
ICS150	150	354	1079	1236	1392	1535	1651	1726	1742	1609

Correction factor for ΔP ($f_{\Delta P}$)

ΔP (bar)	Correction factor
0.2	1.00
0.25	0.89
0.3	0.82
0.4	0.71
0.5	0.63
0.6	0.58

Correction factor for circulation rate (f_{rec})

Circulation rate	Correction factor
2	0.77
3	0.90
4	1
6	1.13
8	1.20
10	1.25

US units

Capacity table for nominal conditions, Q_N [Tons of Refrigeration], circulation rate = 4, $\Delta P = 3$ psi

R 744

Type	Valve body size	C_v (USgal/min)	Evaporating temperature [°F]							
			-60°F	-40°F	-20°F	0°F	20°F	40°F	60°F	80°F
ICS25-5	25	2	1.5	1.7	2.0	2.2	2.3	2.4	2.4	1.8
ICS25-10		4.1	3.0	3.5	4.0	4.5	4.8	5.0	4.8	3.7
ICS25-15		7	5.2	6.0	6.9	7.7	8.2	8.6	8.3	6.4
ICS25-20		9.3	6.9	8.1	9.2	10.2	11.0	11.4	11.1	8.5
ICS25-25		13.3	10.0	11.6	13.2	14.7	15.8	16.4	15.9	12.3
ICS32	32	20	14.7	17.2	19.4	21.7	23.3	24.2	23.5	18.2
ICS40	40	31	23.3	27.3	31.0	34.5	37.0	38.5	37.3	28.8
ICS50	50	51	38.0	44.5	50.5	56.0	60.5	62.7	60.8	47.0
ICS65	65	81	60.5	71.0	80.0	89.0	96.0	100	96.7	75.0
ICS80	80	98	73	85	97	108	115	120	117	90
ICS100	100	165	123	143	163	181	194	202	196	151
ICS125	125	240	179	208	237	264	282	294	286	220
ICS150	150	410	305	355	405	451	483	502	488	375

Correction factor for ΔP ($f_{\Delta P}$)

ΔP (psi)	Correction factor
3	1.00
4	0.87
5	0.79
6	0.72
7	0.66
8	0.62

Correction factor for circulation rate (f_{rec})

Circulation rate	Correction factor
2	0.77
3	0.90
4	1
6	1.13
8	1.20
10	1.25

Nominal capacities

Wet suction line

R 134a

SI units

Capacity table for nominal conditions, Q_N [kW], circulation rate = 4, $\Delta P = 0.2$ bar

Type	Valve body size	K_v (m ³ /h)	Evaporating temperature [°C]						
			-40	-30	-20	-10	0	10	20
ICS25-5	25	1.7	1.1	1.6	1.9	2.3	2.7	3.1	3.4
ICS25-10		3.5	2.3	3.2	4.0	4.8	5.6	6.4	7.1
ICS25-15		6	4.0	5.5	6.8	8.2	9.5	10.9	12.2
ICS25-20		8	5.4	7.3	9.1	10.9	12.7	14.5	16.2
ICS25-25		11.5	7.7	10.5	13.1	15.7	18.2	20.9	23.3
ICS32	32	17	11.4	15.5	19.4	23.2	27.0	30.8	34.5
ICS40	40	27	18.1	24.6	30.8	36.8	42.8	49.0	54.8
ICS50	50	44	29.5	40.2	50.2	60.0	69.8	79.8	89.3
ICS65	65	70	47.0	63.9	79.9	95.5	111	127	142
ICS80	80	85	57	78	97	116	135	154	172
ICS100	100	142	95	130	161	194	225	258	288
ICS125	125	207	138	190	235	282	329	376	419
ICS150	150	354	236	324	403	483	562	643	717

Correction factor for ΔP ($f_{\Delta P}$)

ΔP (bar)	Correction factor
0.2	1.00
0.25	0.89
0.3	0.82
0.4	0.71
0.5	0.63
0.6	0.58

Correction factor for circulation rate (f_{rec})

Circulation rate	Correction factor
2	0.77
3	0.90
4	1
6	1.13
8	1.20
10	1.25

R 134a

US units

Capacity table for nominal conditions, Q_N [Tons of Refrigeration], circulation rate = 4, $\Delta P = 3$ psi

Type	Valve body size	C_v (USgal/min)	Evaporating temperature [°F]						
			-40°F	-20°F	0°F	20°F	40°F	60°F	80°F
ICS25-5	25	2	0.3	0.5	0.6	0.7	0.8	1.0	1.1
ICS25-10		4.1	0.6	1.0	1.2	1.5	1.7	2.0	2.2
ICS25-15		7	1.0	1.6	2.1	2.5	2.9	3.4	3.8
ICS25-20		9.3	1.4	2.2	2.8	3.3	3.9	4.5	5.1
ICS25-25		13.3	2.0	3.1	3.9	4.8	5.6	6.4	7.2
ICS32	32	20	3.0	4.7	5.9	7.2	8.4	9.7	10.9
ICS40	40	31	4.6	7.2	9.2	11.1	13.1	15.0	16.8
ICS50	50	51	7.6	11.9	15.1	18.3	21.5	24.6	27.7
ICS65	65	81	12.1	18.9	24.1	29.1	34.1	39.1	44.0
ICS80	80	98	15	23	29	35	41	48	53
ICS100	100	165	25	39	49	59	69	80	90
ICS125	125	240	36	57	71	86	100	117	130
ICS150	150	410	61	97	122	147	171	199	223

Correction factor for ΔP ($f_{\Delta P}$)

ΔP (psi)	Correction factor
3	1.00
4	0.87
5	0.79
6	0.72
7	0.66
8	0.62

Correction factor for circulation rate (f_{rec})

Circulation rate	Correction factor
2	0.77
3	0.90
4	1
6	1.13
8	1.20
10	1.25

Nominal capacities

Wet suction line

SI units

Capacity table for nominal conditions, Q_N [kW], circulation rate = 4, $\Delta P = 0.2$ bar

R 404A

Type	Valve body size	K_v (m ³ /h)	Evaporating temperature [°C]							
			-50	-40	-30	-20	-10	0	10	20
ICS25-5	25	1.7	1.5	1.9	2.2	2.6	3.0	3.3	3.7	4.0
ICS25-10		3.5	3.0	3.8	4.5	5.3	6.1	6.9	7.6	8.2
ICS25-15		6	5.2	6.5	7.8	9.1	10.4	11.7	13.0	14.0
ICS25-20		8	6.9	8.7	10.4	12.2	14.0	15.7	17.3	18.8
ICS25-25		11.5	10.0	12.5	15.0	17.5	20.0	22.6	25.0	27.0
ICS32	32	17	14.7	18.5	22.0	26.0	29.7	33.2	37.0	40.0
ICS40	40	27	23.3	29.3	35.0	41.0	47.0	53.0	59.0	63.0
ICS50	50	44	38.0	48.0	57.0	67.0	77.0	86.0	95.0	103
ICS65	65	70	60.0	76.0	91.0	106	122	137	152	164
ICS80	80	85	74	93	110	129	148	166	185	199
ICS100	100	142	123	155	184	216	248	278	308	333
ICS125	125	207	179	226	268	315	361	405	449	485
ICS150	150	354	306	386	459	539	618	693	769	830

Correction factor for ΔP ($f_{\Delta P}$)

ΔP (bar)	Correction factor
0.2	1.00
0.25	0.89
0.3	0.82
0.4	0.71
0.5	0.63
0.6	0.58

Correction factor for circulation rate (f_{rec})

Circulation rate	Correction factor
2	0.77
3	0.90
4	1
6	1.13
8	1.20
10	1.25

US units

Capacity table for nominal conditions, Q_N [Tons of Refrigeration], circulation rate = 4, $\Delta P = 3$ psi

R 404A

Type	Valve body size	C_v (USgal/min)	Evaporating temperature [°F]							
			-60°F	-40°F	-20°F	0°F	20°F	40°F	60°F	80°F
ICS25-5	25	2	0.4	0.5	0.7	0.8	0.9	1.0	1.1	1.2
ICS25-10		4.1	0.8	1.1	1.3	1.6	1.8	2.1	2.3	2.3
ICS25-15		7	1.4	1.9	2.3	2.7	3.2	3.6	3.9	2.5
ICS25-20		9.3	1.9	2.5	3.1	3.6	4.2	4.8	5.3	5.7
ICS25-25		13.3	2.8	3.6	4.4	5.2	6.0	6.8	7.5	8.1
ICS32	32	20	4.1	5.3	6.5	7.7	8.9	10.1	11.1	12.0
ICS40	40	31	6.5	8.5	10.3	12.2	14.2	16.0	17.7	19.1
ICS50	50	51	10.6	13.8	16.8	19.9	23.0	26.0	29.0	31.0
ICS65	65	81	16.9	22.0	26.7	31.7	36.7	41.5	46.0	49.5
ICS80	80	98	20	26	32	38	44	50	55	56
ICS100	100	165	34	44	55	64	74	84	93	95
ICS125	125	240	49	64	79	94	108	123	135	138
ICS150	150	410	84	110	136	160	185	209	231	236

Correction factor for ΔP ($f_{\Delta P}$)

ΔP (psi)	Correction factor
3	1.00
4	0.87
5	0.79
6	0.72
7	0.66
8	0.62

Correction factor for circulation rate (f_{rec})

Circulation rate	Correction factor
2	0.77
3	0.90
4	1
6	1.13
8	1.20
10	1.25

Nominal capacities

Wet suction line

R 22

SI units

Capacity table for nominal conditions, Q_N [kW], circulation rate = 4, $\Delta P = 0.2$ bar

Type	Valve body size	K_v (m ³ /h)	Evaporating temperature [°C]							
			-50	-40	-30	-20	-10	0	10	20
ICS25-5	25	1.7	1.4	1.8	2.2	2.6	3.0	3.4	3.8	4.2
ICS25-10		3.5	2.8	3.7	4.6	5.4	6.2	7.0	7.9	8.7
ICS25-15		6	4.8	6.3	7.8	9.2	10.6	12.0	13.5	14.8
ICS25-20		8	6.4	8.4	10.4	12.2	14.2	16.0	17.9	19.8
ICS25-25		11.5	9.2	12.0	15.0	17.6	20.4	23.0	25.8	28.4
ICS32	32	17	13.6	17.8	22.1	26.0	30.1	34.0	38.1	42.0
ICS40	40	27	21.5	28.3	35.1	41.3	47.8	54.0	60.6	66.7
ICS50	50	44	35.1	46.1	57.2	67.3	77.9	88.0	98.7	109
ICS65	65	70	55.8	73.3	91.0	107	124	140	157	173
ICS80	80	85	68	89	111	130	150	170	191	210
ICS100	100	142	114	149	185	217	251	284	319	351
ICS125	125	207	166	217	269	317	366	414	464	512
ICS150	150	354	284	372	461	542	627	708	794	875

Correction factor for ΔP ($f_{\Delta P}$)

ΔP (bar)	Correction factor
0.2	1.00
0.25	0.89
0.3	0.82
0.4	0.71
0.5	0.63
0.6	0.58

Correction factor for circulation rate (f_{rec})

Circulation rate	Correction factor
2	0.77
3	0.90
4	1
6	1.13
8	1.20
10	1.25

US units

Capacity table for nominal conditions, Q_N [Tons of Refrigeration], circulation rate = 4, $\Delta P = 3$ psi

R 22

Type	Valve body size	C_v (USgal/min)	Evaporating temperature [°F]							
			-60°F	-40°F	-20°F	0°F	20°F	40°F	60°F	80°F
ICS25-5	25	2	0.2	0.5	0.7	0.8	0.9	1.1	1.2	1.3
ICS25-10		4.1	0.5	1.1	1.3	1.6	1.9	2.2	2.4	2.7
ICS25-15		7	0.8	1.8	2.3	2.8	3.2	3.7	4.1	4.6
ICS25-20		9.3	1.1	2.4	3.0	3.7	4.3	4.9	5.5	6.1
ICS25-25		13.3	1.6	3.5	4.4	5.2	6.1	7.0	7.9	8.7
ICS32	32	20	2.4	5.2	6.5	7.9	9.2	10.5	11.9	13.1
ICS40	40	31	3.7	8.1	10.1	12.2	14.3	16.3	18.4	20.3
ICS50	50	51	6.1	13.3	16.7	20.1	23.5	26.9	30.2	33.4
ICS65	65	81	9.69	21.1	26.5	31.9	37.3	42.7	48.0	53.0
ICS80	80	98	11	25	32	39	45	52	58	64
ICS100	100	165	19	43	54	65	76	88	98	108
ICS125	125	240	28	62	79	95	110	127	142	157
ICS150	150	410	48	107	135	162	188	217	243	269

Correction factor for ΔP ($f_{\Delta P}$)

ΔP (psi)	Correction factor
3	1.00
4	0.87
5	0.79
6	0.72
7	0.66
8	0.62

Correction factor for circulation rate (f_{rec})

Circulation rate	Correction factor
2	0.77
3	0.90
4	1
6	1.13
8	1.20
10	1.25

Nominal capacities

Dry suction line

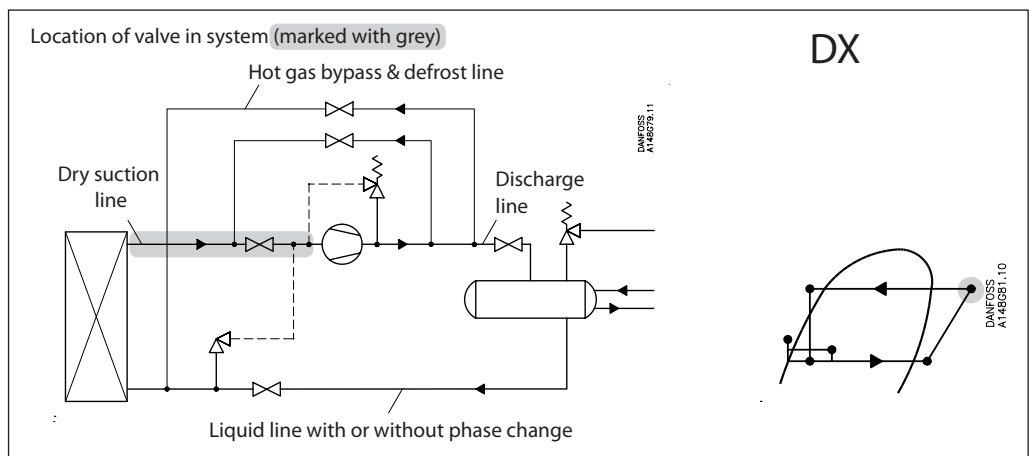
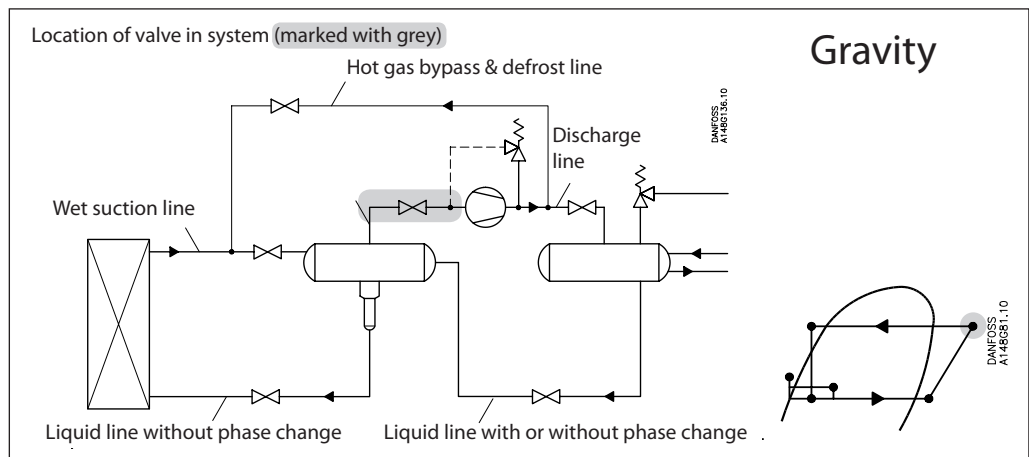
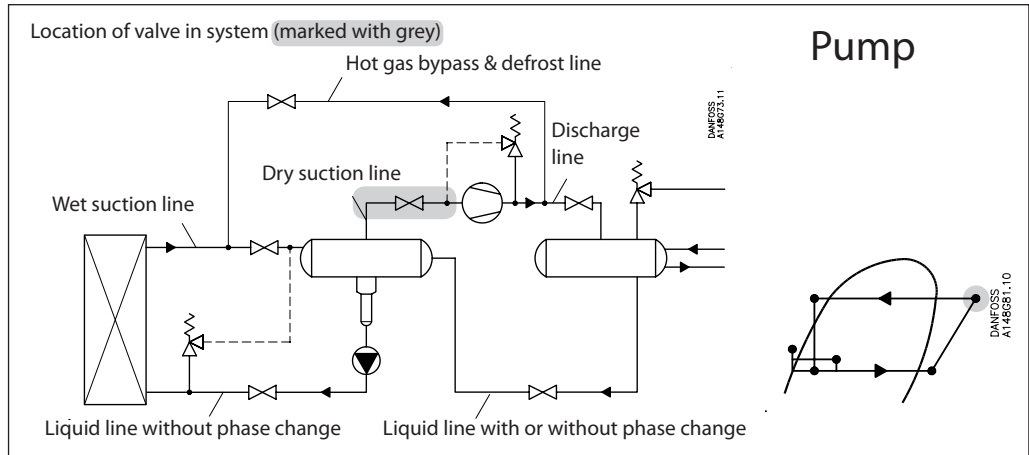

Nominal capacities

Dry suction line

SI units

Calculation example (R 717 capacities):

An application has following running conditions:

$$\begin{aligned} T_e &= -20\text{ }^\circ\text{C} \\ Q_o &= 90\text{ kW} \\ T_{liq} &= 10\text{ }^\circ\text{C} \\ \text{Max. } \Delta p &= 0.3\text{ bar} \end{aligned}$$

 The capacity table is based on nominal condition (pressure drop $\Delta p = 0.2\text{ bar}$, $T_{liq} = 30\text{ }^\circ\text{C}$)

Therefore the actual capacity must be corrected to nominal condition by means of correction factors.

 Correction factor for $\Delta p 0.3\text{ bar}$ $f_{\Delta p} = 0.82$

 Correction factor for liquid temperature $f_{T_{liq}} = 0.92$

$$Q_n = Q_o \times f_{\Delta p} \times f_{T_{liq}} = 90 \times 0.82 \times 0.92 = 67.9\text{ kW}$$

 From the capacity table a ICS 32 with Q_n capacity 92 kW is selected.

US units

Calculation example (R 717 capacities):

An application has following running conditions:

$$\begin{aligned} T_e &= 0\text{ }^\circ\text{F} \\ Q_o &= 20\text{ TR} \\ T_{liq} &= 50\text{ }^\circ\text{F} \\ \text{Max. } \Delta p &= 4\text{ psi} \end{aligned}$$

 The capacity table is based on nominal condition (pressure drop $\Delta p = 3\text{ psi}$, $T_{liq} = 90\text{ }^\circ\text{F}$)

Therefore the actual capacity must be corrected to nominal condition by means of correction factors.

 Correction factor for $\Delta p 4\text{ psi}$, $T_{liq} = 0.87$

 Correction factor for liquid temperature $f_{T_{liq}} = 0.92$

$$Q_n = Q_o \times f_{\Delta p} \times f_{T_{liq}} = 20 \times 0.87 \times 0.92 = 16\text{ TR}$$

 From the capacity table a ICS 25-25 with Q_n capacity 18.7 TR is selected.

Nominal capacities

Dry suction line

SI units

Capacity table for nominal conditions, Q_N [kW],
 $T_{liq} = 30^\circ\text{C}$,
 $\Delta P = 0.2$ bar
 Superheating = 8°C

R 717

Type	Valve body size	K_v (m ³ /h)	Evaporating temperature [°C]							
			-50	-40	-30	-20	-10	0	10	20
ICS25-5	25	1.7	4.4	5.7	7.3	9.2	11.4	14.0	16.5	19.6
ICS25-10		3.5	9.0	11.7	15.0	19.0	23.5	28.5	34.0	40.0
ICS25-15		6	15.5	20.0	26.0	32.5	40.0	49.0	59.0	69.0
ICS25-20		8	20.6	27.0	34.0	43.3	54.0	65.0	78.0	92.0
ICS25-25		11.5	29.7	38.0	49.0	63.0	77.0	94	112	132
ICS32	32	17	44.0	57.0	73.0	92.0	114	139	166	196
ICS40	40	27	70.0	90.0	116	146	181	220	263	311
ICS50	50	44	113	147	189	239	295	359	429	507
ICS65	65	70	181	234	301	380	470	570	682	807
ICS80	80	85	219	284	365	461	570	694	829	978
ICS100	100	142	367	475	609	770	952	1159	1384	1634
ICS125	125	207	534	692	888	1123	1388	1690	2018	2381
ICS150	150	354	914	1183	1519	1921	2374	2890	3451	4072

Correction factor for ΔP ($f_{\Delta P}$)

ΔP (bar)	Correction factor
0.2	1.00
0.25	0.89
0.3	0.82
0.4	0.71
0.5	0.63
0.6	0.58

Correction factor for liquid temperature (T_{liq})

Liquid temperature	Correction factor
-20°C	0.82
-10°C	0.86
0°C	0.88
10°C	0.92
20°C	0.96
30°C	1.00
40°C	1.04
50°C	1.09

US units

Capacity table for nominal conditions, Q_N [Tons of Refrigeration],
 $T_{liq} = 90^\circ\text{F}$,
 $\Delta P = 3$ psi
 Superheating = 12°F

R 717

Type	Valve body size	C_v (USgal/min)	Evaporating temperature [°F]							
			-60°F	-40°F	-20°F	0°F	20°F	40°F	60°F	80°F
ICS25-5	25	2	1.3	1.6	2.2	2.8	3.5	4.3	5.2	6.2
ICS25-10		4.1	2.5	3.4	4.4	5.7	7.2	8.9	10.7	12.8
ICS25-15		7	4.2	5.7	7.6	9.8	12.3	15.2	18.4	22.0
ICS25-20		9.3	5.6	7.6	10.1	13.0	16.4	20.2	24.5	29.3
ICS25-25		13.3	8.1	11.0	14.5	18.7	23.6	29.0	35.3	42.0
ICS32	32	20	12.0	16.2	21.5	27.7	35.0	43.0	52.0	62.0
ICS40	40	31	19.0	25.8	34.2	44.0	55.5	68.0	83.0	99.0
ICS50	50	51	30.9	42.0	55.7	72.0	90.0	111	135	161
ICS65	65	81	48.2	67.0	89.0	114	144	177	215	256
ICS80	80	98	60	80	107	137	173	213	258	308
ICS100	100	165	101	135	180	231	291	358	435	519
ICS125	125	240	146	197	261	336	424	521	632	754
ICS150	150	410	250	336	447	575	724	891	1080	1288

Correction factor for ΔP ($f_{\Delta P}$)

ΔP (psi)	Correction factor
3	1.00
4	0.87
5	0.79
6	0.72
7	0.66
8	0.62

Correction factor for superheat (T_s)

T_s	Correction factor
10°F	1.00
14°F	1.00
18°F	1.00
20°F	1.00

Correction factor for liquid temperature (T_{liq})

Liquid temperature	Correction factor
-10°F	0.82
10°F	0.85
30°F	0.88
50°F	0.92
70°F	0.96
90°F	1.00
110°F	1.04
130°F	1.09

Nominal capacities

Dry suction line

R 744

SI units

Capacity table at nominal conditions, Q_N [kW],
 $T_{liq} = 10^\circ\text{C}$,
 $\Delta p = 0.2$ bar
 Superheating = 8°C

Type	Valve body size	K_v (m ³ /h)	Evaporating temperature [°C]							
			-50	-40	-30	-20	-10	0	10	20
ICS25-5	25	1.7	6.0	7.3	8.8	10.4	12.0	14.0	15.8	17.7
ICS25-10		3.5	12.3	15.0	18.0	21.5	25.0	28.6	32.5	36.5
ICS25-15		6	21.0	26.0	31.0	37.0	43.0	49.0	56.0	63.0
ICS25-20		8	28.0	34.0	41.0	49.0	57.0	67.0	75.0	84.0
ICS25-25		11.5	40.0	49.0	59.0	70.0	82.0	94.0	107	120
ICS32	32	17	60.0	73.0	88.0	104	121	139	158	177
ICS40	40	27	95.0	116	139	165	192	221	251	281
ICS50	50	44	154	189	227	268	313	360	409	459
ICS65	65	70	245	300	361	427	498	573	650	730
ICS80	80	85	298	365	438	520	605	697	791	887
ICS100	100	142	498	609	732	869	1011	1165	1322	1482
ICS125	125	207	726	888	1067	1266	1474	1699	1927	2161
ICS150	150	354	1242	1518	1824	2166	2520	2905	3295	3696

Correction factor for ΔP ($f_{\Delta P}$)

ΔP (bar)	Correction factor
0.2	1.00
0.25	0.89
0.3	0.82
0.4	0.71
0.5	0.63
0.6	0.58

Correction factor for liquid temperature (T_{liq})

Liquid temperature	Correction factor
-20°C	0.52
-10°C	0.67
0°C	0.91
10°C	1.00
15°C	1.09

R 744

US units

Capacity table at nominal conditions, Q_N [Tons of Refrigeration],
 $T_{liq} = 50^\circ\text{F}$,
 $\Delta p = 3$ psi
 Superheating = 12°F

Type	Valve body size	C_v (USgal/min)	Evaporating temperature [°F]							
			-60°F	-40°F	-20°F	0°F	20°F	40°F	60°F	80°F
ICS25-5	25	2	1.7	2.1	2.6	3.1	3.7	4.2	4.9	5.4
ICS25-10		4.1	3.4	4.3	5.3	6.4	7.5	8.7	10.0	11.2
ICS25-15		7	5.9	7.4	9.1	10.9	12.9	15.0	17.0	19.2
ICS25-20		9.3	7.9	9.9	12.1	14.5	17.2	20.0	22.8	25.5
ICS25-25		13.3	11.3	14.2	17.4	21.0	24.7	28.6	32.8	36.7
ICS32	32	20	16.7	21.0	25.7	31.0	36.5	42.4	48.5	54.3
ICS40	40	31	26.6	33.3	41.0	49.0	58.0	67.0	77.0	86.0
ICS50	50	51	43.3	54.3	66.5	80.0	94.0	110	125	141
ICS65	65	81	69.0	86.5	106	127	150	174	199	223
ICS80	80	98	83	104	128	153	181	210	240	269
ICS100	100	165	140	175	215	258	305	353	404	453
ICS125	125	240	203	255	313	375	443	513	588	658
ICS150	150	410	347	435	534	641	757	877	1005	1124

Correction factor for ΔP ($f_{\Delta P}$)

ΔP (psi)	Correction factor
3	1.00
4	0.87
5	0.79
6	0.72
7	0.66
8	0.62

Correction factor for superheat (T_s)

T_s	Correction factor
10°F	1.00
14°F	1.00
18°F	1.00
20°F	1.00

Correction factor for liquid temperature (T_{liq})

Liquid temperature	Correction factor
-10°F	0.48
10°F	0.64
30°F	0.88
50°F	1.00

Nominal capacities

Dry suction line

SI units

Capacity table for nominal conditions, Q_N [kW],
 $T_{liq} = 30^\circ\text{C}$,
 $\Delta P = 0.2$ bar
 Superheating = 8°C

R 134a

Type	Valve body size	K_v (m^3/h)	Evaporating temperature [$^\circ\text{C}$]						
			-40	-30	-20	-10	0	10	20
ICS25-5	25	1.7	1.5	1.9	2.5	3.2	4.0	4.9	5.9
ICS25-10		3.5	3.0	4.0	5.2	6.5	8.2	10.0	12.1
ICS25-15		6	5.2	6.9	8.9	11.2	14.0	17.2	20.8
ICS25-20		8	6.9	9.1	11.9	15.0	18.6	23.0	28.0
ICS25-25		11.5	9.9	13.1	17.1	22.0	27.0	33.0	40.0
ICS32	32	17	14.7	19.0	25.0	32.0	40.0	49.0	59.0
ICS40	40	27	23.0	31.0	40.0	51.0	63.0	77.0	94.0
ICS50	50	44	38.0	50.0	65.0	82.0	103	126	153
ICS65	65	70	60.0	80.0	104	131	163	200	243
ICS80	80	85	73	97	126	160	199	244	295
ICS100	100	142	123	161	210	267	332	407	493
ICS125	125	207	179	235	307	389	484	594	719
ICS150	150	354	305	402	524	665	828	1015	1230

Correction factor for ΔP ($f_{\Delta P}$)

ΔP (bar)	Correction factor
0.2	1.00
0.25	0.89
0.3	0.82
0.4	0.71
0.5	0.63
0.6	0.58

Correction factor for liquid temperature (T_{liq})

Liquid temperature	Correction factor
-20 $^\circ\text{C}$	0.66
-10 $^\circ\text{C}$	0.70
0 $^\circ\text{C}$	0.76
10 $^\circ\text{C}$	0.82
20 $^\circ\text{C}$	0.90
30$^\circ\text{C}$	1.00
40 $^\circ\text{C}$	1.13
50 $^\circ\text{C}$	1.29

US units

Capacity table for nominal conditions, Q_N [Tons of Refrigeration],
 $T_{liq} = 90^\circ\text{F}$,
 $\Delta P = 3$ psi
 Superheating= 12°F

R 134a

Type	Valve body size	C_v (USgal/min)	Evaporating temperature [$^\circ\text{F}$]						
			-40 $^\circ\text{F}$	-20 $^\circ\text{F}$	0 $^\circ\text{F}$	20 $^\circ\text{F}$	40 $^\circ\text{F}$	60 $^\circ\text{F}$	80 $^\circ\text{F}$
ICS25-5	25	2	0.5	0.6	0.8	1.0	1.3	1.6	1.9
ICS25-10		4.1	0.9	1.2	1.6	2.0	2.6	3.2	4.0
ICS25-15		7	1.5	2.0	2.7	3.5	4.4	5.5	6.8
ICS25-20		9.3	2.0	2.7	3.6	4.7	5.9	7.4	9.1
ICS25-25		13.3	2.9	3.9	5.2	6.7	8.5	10.6	13.0
ICS32	32	20	4.2	5.8	7.7	9.9	12.6	15.7	19.3
ICS40	40	31	6.7	9.2	12.2	15.7	20.0	25.0	30.6
ICS50	50	51	11.0	15.0	19.8	25.7	32.5	40.6	50.0
ICS65	65	81	17.4	23.7	31.5	40.8	52.0	64.6	79.0
ICS80	80	98	21	29	38	49	63	78	95
ICS100	100	165	36	48	64	83	105	131	161
ICS125	125	240	53	70	94	120	153	191	234
ICS150	150	410	90	120	160	205	262	325	399

Correction factor for ΔP ($f_{\Delta P}$)

ΔP (psi)	Correction factor
3	1.00
4	0.87
5	0.79
6	0.72
7	0.66
8	0.62

Correction factor for superheat (T_s)

T_s	Correction factor
10 $^\circ\text{F}$	1.00
14 $^\circ\text{F}$	1.00
18 $^\circ\text{F}$	1.00
20 $^\circ\text{F}$	1.00

Correction factor for liquid temperature (T_{liq})

Liquid temperature	Correction factor
-10 $^\circ\text{F}$	0.64
10 $^\circ\text{F}$	0.68
30 $^\circ\text{F}$	0.74
50 $^\circ\text{F}$	0.81
70 $^\circ\text{F}$	0.89
90$^\circ\text{F}$	1.00
110 $^\circ\text{F}$	1.15
130 $^\circ\text{F}$	1.35

Nominal capacities

Dry suction line

R 404A

SI units

Capacity table for nominal conditions, Q_N [kW],
 $T_{liq} = 30^\circ\text{C}$,
 $\Delta P = 0.2$ bar
 Superheat = 8°C

Type	Valve body size	K_v (m ³ /h)	Evaporating temperature [°C]							
			-50	-40	-30	-20	-10	0	10	20
ICS25-5	25	1.7	1.4	1.8	2.4	3.0	3.8	4.6	5.7	6.8
ICS25-10		3.5	2.8	3.7	4.8	6.2	7.7	9.5	11.6	14.0
ICS25-15		6	4.8	6.4	8.3	10.6	13.2	16.4	20.0	24.0
ICS25-20		8	6.4	8.5	11.0	14.0	17.7	22.0	26.5	32.0
ICS25-25		11.5	9.1	12.2	16.0	20.3	25.5	31.3	38.0	46.0
ICS32	32	17	13.5	18.0	23.5	30.0	37.5	46.0	56.0	68.0
ICS40	40	27	21.5	28.5	37.0	47.5	60.0	74.0	90.0	108
ICS50	50	44	35.0	47.0	61.0	78.0	97.0	120	146	175
ICS65	65	70	55.0	74.0	97.0	123.0	155	190	232	280
ICS80	80	85	68	90	118	150	188	232	282	340
ICS100	100	142	113	151	197	250	314	387	471	568
ICS125	125	207	165	220	287	365	458	564	687	827
ICS150	150	354	283	375	490	624	783	964	1175	1415

Correction factor for ΔP ($f_{\Delta P}$)

ΔP (bar)	Correction factor
0.2	1.00
0.25	0.89
0.3	0.82
0.4	0.71
0.5	0.63
0.6	0.58

Correction factor for liquid temperature (T_{liq})

Liquid temperature	Correction factor
-20°C	0.55
-10°C	0.60
0°C	0.66
10°C	0.74
20°C	0.85
30°C	1.00
40°C	1.23
50°C	1.68

R 404A

US units

Capacity table for nominal conditions, Q_N [Tons of Refrigeration],
 $T_{liq} = 90^\circ\text{F}$,
 $\Delta P = 3$ psi
 Superheat = 12°F

Type	Valve body size	C_v (USgal/min)	Evaporating temperature [°F]							
			-60°F	-40°F	-20°F	0°F	20°F	40°F	60°F	80°F
ICS25-5	25	2	0.4	0.5	0.7	0.9	1.1	1.4	1.8	2.1
ICS25-10		4.1	0.7	1.0	1.4	1.8	2.3	2.9	3.6	4.4
ICS25-15		7	1.3	1.8	2.4	3.1	4.0	5.0	6.2	7.5
ICS25-20		9.3	1.7	2.3	3.1	4.1	5.3	6.6	8.2	10.0
ICS25-25		13.3	2.4	3.4	4.5	5.9	7.6	9.6	11.8	14.4
ICS32	32	20	3.6	5.0	6.7	8.8	11.2	14.1	17.5	21.3
ICS40	40	31	5.7	7.9	10.6	13.9	17.8	22.4	27.7	34.0
ICS50	50	51	9.3	12.9	17.3	22.7	29.0	36.6	45.1	55.0
ICS65	65	81	14.8	20.5	27.5	36.0	46.2	58.0	72.0	88.0
ICS80	80	98	18	25	33	43	55	70	87	105
ICS100	100	165	30	42	56	73	93	118	146	177
ICS125	125	240	44	60	82	107	136	171	213	258
ICS150	150	410	75	103	139	182	232	292	363	441

Correction factor for ΔP ($f_{\Delta P}$)

ΔP (psi)	Correction factor
3	1.00
4	0.87
5	0.79
6	0.72
7	0.66
8	0.62

Correction factor for superheat (T_s)

T_s	Correction factor
10°F	1.00
14°F	1.00
18°F	1.00
20°F	1.00

Correction factor for liquid temperature (T_{liq})

Liquid temperature	Correction factor
-10°F	0.52
10°F	0.57
30°F	0.63
50°F	0.72
70°F	0.83
90°F	1.00
110°F	1.29
130°F	1.92

Nominal capacities

Dry suction line

SI units

Capacity table for nominal conditions, Q_N [kW],
 $T_{liq} = 30^\circ\text{C}$,
 $\Delta P = 0.2$ bar
 Superheat = 8°C

R 22

Type	Valve body size	K_v (m ³ /h)	Evaporating temperature [°C]							
			-50	-40	-30	-20	-10	0	10	20
ICS25-5	25	1.7	1.7	2.3	2.9	3.6	4.4	5.3	6.2	7.4
ICS25-10		3.5	3.6	4.7	5.9	7.4	9.0	10.9	12.9	15.2
ICS25-15		6	6.2	8.0	10.1	12.6	15.4	18.6	22.0	26.0
ICS25-20		8	8.2	10.7	13.5	16.8	20.6	24.8	29.4	34.6
ICS25-25		11.5	11.8	15.3	19.4	24.2	29.6	35.7	42.2	49.8
ICS32	32	17	17.5	22.7	28.7	35.7	43.7	52.7	62.4	73.6
ICS40	40	27	27.8	36.0	45.5	56.7	69.4	83.7	99.1	117
ICS50	50	44	45.3	58.6	74.2	92.4	113	136	162	190
ICS65	65	70	72.0	93.3	118	147	180	217	257	303
ICS80	80	85	87	114	144	179	219	264	312	368
ICS100	100	142	146	190	240	299	365	441	521	615
ICS125	125	207	212	277	349	436	533	642	760	897
ICS150	150	354	363	473	598	745	911	1098	1300	1534

Correction factor for ΔP ($f_{\Delta P}$)

ΔP (bar)	Correction factor
0.2	1.00
0.25	0.89
0.3	0.82
0.4	0.71
0.5	0.63
0.6	0.58

Correction factor for liquid temperature (T_{liq})

Liquid temperature	Correction factor
-20°C	0.71
-10°C	0.75
0°C	0.80
10°C	0.86
20°C	0.92
30°C	1.00
40°C	1.09
50°C	1.22

US units

Capacity table for nominal conditions, Q_N [Tons of Refrigeration],
 $T_{liq} = 90^\circ\text{F}$,
 $\Delta P = 3$ psi
 Superheat = 12°F

R 22

Type	Valve body size	C_v (USgal/min)	Evaporating temperature [°F]							
			-60°F	-40°F	-20°F	0°F	20°F	40°F	60°F	80°F
ICS25-5	25	2	0.5	0.7	0.8	1.1	1.3	1.6	2.0	2.3
ICS25-10		4.1	1.0	1.3	1.7	2.2	2.7	3.4	4.0	4.8
ICS25-15		7	1.7	2.3	3.0	3.8	4.7	5.7	6.9	8.2
ICS25-20		9.3	2.3	3.0	3.9	5.0	6.2	7.6	9.2	10.9
ICS25-25		13.3	3.2	4.3	5.6	7.2	8.9	10.9	13.1	15.6
ICS32	32	20	4.9	6.5	8.5	10.8	13.4	16.4	19.8	23.5
ICS40	40	31	7.5	10.1	13.1	16.7	20.8	25.4	30.6	36.4
ICS50	50	51	12.4	16.6	21.6	27.5	34.2	41.8	50.4	59.9
ICS65	65	81	19.7	26.4	34.3	43.6	54.3	66.4	80.0	95.1
ICS80	80	98	24	32	41	53	65	80	97	115
ICS100	100	165	40	54	69	89	110	135	163	193
ICS125	125	240	59	79	101	130	160	196	237	281
ICS150	150	410	100	134	172	222	273	335	405	480

Correction factor for ΔP ($f_{\Delta P}$)

ΔP (psi)	Correction factor
3	1.00
4	0.87
5	0.79
6	0.72
7	0.66
8	0.62

Correction factor for superheat (T_s)

T_s	Correction factor
10°F	1.00
14°F	1.00
18°F	1.00
20°F	1.00

Correction factor for liquid temperature (T_{liq})

Liquid temperature	Correction factor
-10°F	0.73
10°F	0.77
30°F	0.82
50°F	0.87
70°F	0.93
90°F	1.00
110°F	1.09
130°F	1.20

Nominal capacities

Discharge line

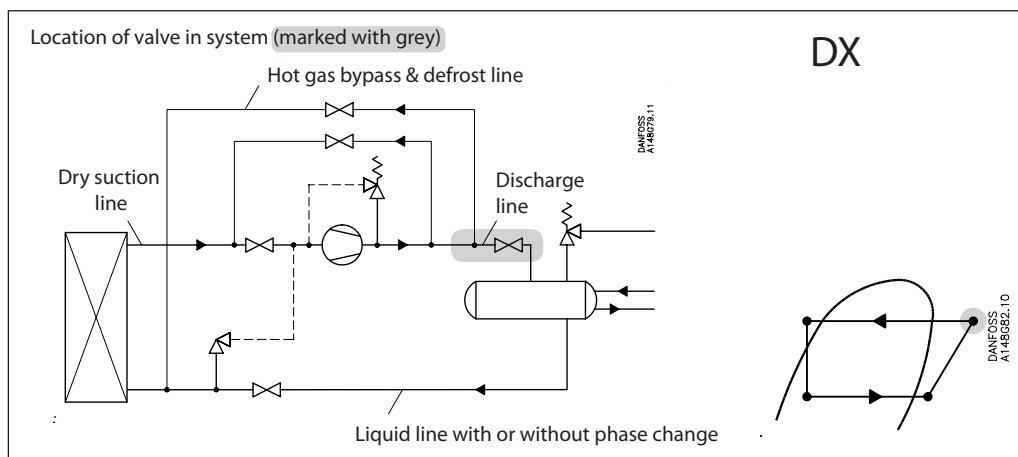
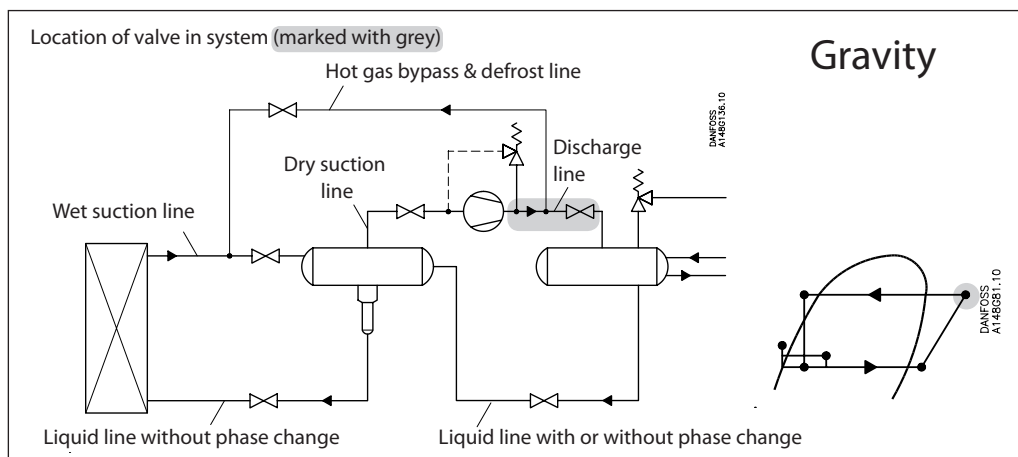
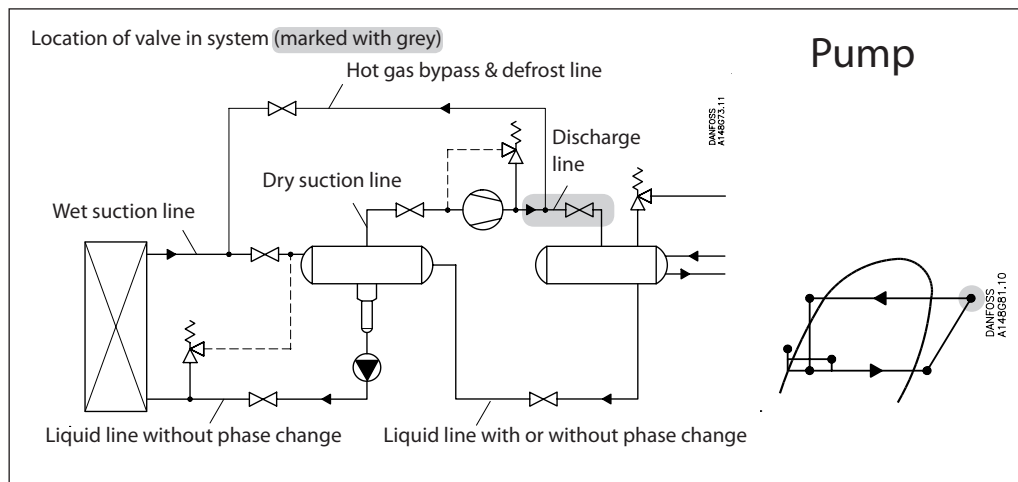

Nominal capacities

Discharge line

SI units

Calculation example (R 717 capacities):

An application has following running conditions:

$$\begin{aligned} T_e &= -20\text{ }^\circ\text{C} \\ Q_o &= 90\text{ kW} \\ T_{liq} &= 10\text{ }^\circ\text{C} \\ \text{Max. } \Delta p &= 0.4\text{ bar} \\ T_{disch.} &= 60\text{ }^\circ\text{C} \end{aligned}$$

The capacity table is based on nominal condition ($\Delta p = 0.2\text{ bar}$, $T_{liq} = 30\text{ }^\circ\text{C}$, $P_{disch.} = 12\text{ bar}$, $T_{disch.} = 80\text{ }^\circ\text{C}$)

Therefore the actual capacity must be corrected to nominal condition by means of correction factors.

 Correction factor for Δp 0.4 bar $f_{\Delta p} = 0.71$

 Correction factor for liquid temperature $f_{T_{liq}} = 0.92$

 Correction factor for $T_{disch.}$ 60°C, $f_{disch.} = 0.97$

$$\begin{aligned} Q_n &= Q_o \times f_{\Delta p} \times f_{T_{liq}} \times f_{T_{disch.}} = \\ 90 \times 0.71 \times 0.92 \times 0.97 &= 57\text{ kW} \end{aligned}$$

From the capacity table a ICS 25-15 with Q_n capacity 73 kW is selected.

US units

Calculation example (R 717 capacities):

An application has following running conditions:

$$\begin{aligned} T_e &= 0\text{ }^\circ\text{F} \\ Q_o &= 18\text{ TR} \\ T_{liq} &= 50\text{ }^\circ\text{F} \\ \text{Max. } \Delta p &= 5.8\text{ psi} \\ T_{disch.} &= 120\text{ }^\circ\text{F} \end{aligned}$$

The capacity table is based on nominal conditions ($\Delta p = 3\text{ psi}$, $T_{liq} = 90\text{ }^\circ\text{F}$, $P_{disch.} = 185\text{ psi}$, $T_{disch.} = 180\text{ }^\circ\text{F}$)

Therefore the actual capacity must be corrected to nominal condition by means of correction factors.

 Correction factor for Δp 5.8 psi, $f_{\Delta p} = 0.72$

 Correction factor for liquid temperature $f_{T_{liq}} = 0.92$

 Correction factor for $T_{disch.}$ 120°C, $f_{disch.} = 0.95$

$$\begin{aligned} Q_n &= Q_o \times f_{\Delta p} \times f_{T_{liq}} \times f_{T_{disch.}} = \\ 18 \times 0.72 \times 0.92 \times 0.95 &= 11.3\text{ TR} \end{aligned}$$

From the capacity table a ICS 25-10 with Q_n capacity 12.0 TR is selected.

Nominal capacities

Discharge line

SI units

Capacity table for nominal conditions, Q_N [kW],
 $T_{liq} = 30^\circ\text{C}$,
 $P_{disch.} = 12 \text{ bar}$,
 $\Delta P = 0.2 \text{ bar}$,
 $T_{disch.} = 80^\circ\text{C}$
 Superheat = 8°C

R 717

Type	Valve body size	K_v (m^3/h)	Evaporating temperature [$^\circ\text{C}$]							
			-50	-40	-30	-20	-10	0	10	20
ICS25-5	25	1.7	19.8	20.2	20.5	20.7	20.9	21.1	21.3	21.5
ICS25-10		3.5	40.8	41.5	42.0	42.5	43.0	43.5	44.0	44.2
ICS25-15		6	70.0	71.0	72.0	73.0	74.0	74.8	75.4	76.0
ICS25-20		8	93.0	95.0	96.0	97.5	99.0	99.7	101	101
ICS25-25		11.5	134	136	138	140	142	143	144	145
ICS32	32	17	199	201	205	207	209	211	213	215
ICS40	40	27	315	320	325	329	333	336	339	341
ICS50	50	44	514	521	529	536	542	548	553	556
ICS65	65	70	817	829	843	854	864	872	879	885
ICS80	80	85	991	1007	1022	1035	1048	1058	1067	1074
ICS100	100	142	1656	1682	1707	1729	1750	1767	1783	1794
ICS125	125	207	2414	2453	2489	2521	2551	2575	2600	2616
ICS150	150	354	4129	4194	4257	4311	4363	4404	4446	4473

Correction factor for ΔP ($f_{\Delta P}$)

ΔP (bar)	Correction factor
0.2	1.00
0.25	0.89
0.3	0.82
0.4	0.71
0.5	0.63
0.6	0.58

Correction factor for discharge temperature ($T_{disch.}$).

Discharge temperature	Correction factor
50 $^\circ\text{C}$	0.96
60 $^\circ\text{C}$	0.97
80$^\circ\text{C}$	1.00
90 $^\circ\text{C}$	1.01
100 $^\circ\text{C}$	1.03
110 $^\circ\text{C}$	1.04
120 $^\circ\text{C}$	1.06

Correction factor for liquid temperature ($T_{liq.}$).

Liquid temperature	Correction factor
-20 $^\circ\text{C}$	0.82
-10 $^\circ\text{C}$	0.86
0 $^\circ\text{C}$	0.88
10 $^\circ\text{C}$	0.92
20 $^\circ\text{C}$	0.96
30$^\circ\text{C}$	1.00
40 $^\circ\text{C}$	1.04
50 $^\circ\text{C}$	1.09

R 717

US units

Capacity table for nominal conditions, Q_N [Tons of Refrigeration],
 $T_{liq} = 90^\circ\text{F}$,
 $\Delta P = 2.9 \text{ psi}$,
 $P_{disch.} = 185 \text{ psi}$,
 $T_{disch.} = 180^\circ\text{F}$
 Superheat = 12°F

Type	Valve body size	C_v (USgal/min)	Evaporating temperature [$^\circ\text{F}$]							
			-60 $^\circ\text{F}$	-40 $^\circ\text{F}$	-20 $^\circ\text{F}$	0 $^\circ\text{F}$	20 $^\circ\text{F}$	40 $^\circ\text{F}$	60 $^\circ\text{F}$	80 $^\circ\text{F}$
ICS25-5	25	2	5.6	5.7	5.8	5.8	5.9	6.0	6.0	6.0
ICS25-10		4.1	11.4	11.6	11.8	12.0	12.1	12.3	12.3	12.4
ICS25-15		7	19.6	20.0	20.3	20.6	20.8	21.0	21.2	21.3
ICS25-20		9.3	26.2	26.6	27.0	27.4	27.8	28.0	28.2	28.3
ICS25-25		13.3	37.6	38.3	39.0	39.4	39.9	40.3	40.5	40.8
ICS32	32	20	55.5	56.5	57.5	58.3	59.0	59.5	60.0	60.3
ICS40	40	31	88.0	90.0	91.0	92.5	94.0	94.5	95.0	95.7
ICS50	50	51	144	146	149	151	153	154	155	156
ICS65	65	81	229	233	237	240	243	245	247	248
ICS80	80	98	275	280	285	289	292	295	297	298
ICS100	100	165	464	472	480	486	492	497	500	502
ICS125	125	240	674	687	698	707	716	723	727	731
ICS150	150	410	1152	1173	1192	1207	1223	1235	1242	1248

Correction factor for ΔP ($f_{\Delta P}$)

ΔP (psi)	Correction factor
3	1.00
4	0.87
5	0.79
6	0.72
7	0.66
8	0.62

Correction factor for discharge temperature ($T_{disch.}$).

Discharge temperature	Correction factor
120 $^\circ\text{F}$	0.95
140 $^\circ\text{F}$	0.97
180 $^\circ\text{F}$	1.00
200 $^\circ\text{F}$	1.02
210 $^\circ\text{F}$	1.02
230 $^\circ\text{F}$	1.04
250 $^\circ\text{F}$	1.06

Correction factor for liquid temperature ($T_{liq.}$).

Liquid temperature	Correction factor
-10 $^\circ\text{F}$	0.82
10 $^\circ\text{F}$	0.85
30 $^\circ\text{F}$	0.88
50 $^\circ\text{F}$	0.92
70 $^\circ\text{F}$	0.96
90 $^\circ\text{F}$	1.00
110 $^\circ\text{F}$	1.04
130 $^\circ\text{F}$	1.09

Nominal capacities

Discharge line

SI units

Capacity table for nominal conditions, Q_N [kW],
 $T_{liq} = 10^\circ\text{C}$,
 $P_{disch} = 10 \text{ bar}$,
 $\Delta P = 0.2 \text{ bar}$
 $T_{disch} = 80^\circ\text{C}$
 Superheat = 8°C

R 744

Type	Valve body size	K_v (m^3/h)	Evaporating temperature [$^\circ\text{C}$]							
			-50	-40	-30	-20	-10	0	10	20
ICS25-5	25	1.7	12.5	12.7	12.8	12.9	12.9	12.9	12.5	12.8
ICS25-10		3.5	25.7	26.2	26.5	26.6	26.6	26.3	25.8	26.4
ICS25-15		6	44.0	45.0	45.3	45.6	45.5	45.1	44.2	45.0
ICS25-20		8	59.0	60.0	60.2	60.7	60.7	60.1	59.0	60.0
ICS25-25		11.5	85.0	86.0	87.0	87.4	87.3	86.5	85.0	87.0
ICS32	32	17	125	127	128	129	129	128	125	128
ICS40	40	27	199	202	204	205	205	203	199	203
ICS50	50	44	324	329	332	334	334	331	324	331
ICS65	65	70	515	523	529	532	531	526	516	527
ICS80	80	85	626	636	642	646	645	640	626	640
ICS100	100	142	1045	1062	1072	1078	1078	1069	1046	1069
ICS125	125	207	1524	1549	1562	1572	1571	1558	1525	1558
ICS150	150	354	2605	2649	2672	2688	2687	2664	2608	2664

Correction factor for ΔP ($f_{\Delta P}$)

ΔP (bar)	Correction factor
0.2	1.00
0.25	0.89
0.3	0.82
0.4	0.71
0.5	0.63
0.6	0.58

Correction factor for discharge temperature (T_{disch}).

Discharge temperature	Correction factor
50 $^\circ\text{C}$	0.96
60 $^\circ\text{C}$	0.97
80$^\circ\text{C}$	1.00
90 $^\circ\text{C}$	1.01
100 $^\circ\text{C}$	1.03
110 $^\circ\text{C}$	1.04
120 $^\circ\text{C}$	1.06

Correction factor for liquid temperature (T_{liq}).

Liquid temperature	Correction factor
-20 $^\circ\text{C}$	0.52
-10 $^\circ\text{C}$	0.67
0 $^\circ\text{C}$	0.91
10$^\circ\text{C}$	1.00
15 $^\circ\text{C}$	1.09

US units

Capacity table for nominal conditions, Q_N [Tons of Refrigeration],
 $T_{liq} = 90^\circ\text{F}$,
 $\Delta P = 3 \text{ psi}$,
 $P_{disch} = 120 \text{ psi}$,
 $T_{disch} = 180^\circ\text{F}$
 Superheat = 12°F

R 744

Type	Valve body size	C_v (USgal/min)	Evaporating temperature [$^\circ\text{F}$]							
			-60 $^\circ\text{F}$	-40 $^\circ\text{F}$	-20 $^\circ\text{F}$	0 $^\circ\text{F}$	20 $^\circ\text{F}$	40 $^\circ\text{F}$	60 $^\circ\text{F}$	80 $^\circ\text{F}$
ICS25-5	25	2	3.4	3.4	3.5	3.5	3.4	3.3	3.2	3.1
ICS25-10		4.1	6.9	7.0	7.1	7.1	7.0	6.8	6.6	6.4
ICS25-15		7	11.9	12.1	12.2	12.2	12.0	11.7	11.3	11.0
ICS25-20		9.3	15.8	16.1	16.2	16.2	16.0	15.6	15.1	14.7
ICS25-25		13.3	22.8	23.1	23.3	23.3	23.0	22.4	21.8	21.1
ICS32	32	20	33.7	34.1	34.5	34.5	34.0	33.1	32.2	31.2
ICS40	40	31	53.4	54.3	54.7	54.7	54.0	52.5	51.0	49.6
ICS50	50	51	87.0	88.4	89.0	89.0	88.0	85.5	83.3	80.8
ICS65	65	81	138	141	142	142	140	136	132	129
ICS80	80	98	167	169	171	171	168	164	159	154
ICS100	100	165	281	285	288	288	284	276	268	260
ICS125	125	240	408	414	419	419	412	401	389	378
ICS150	150	410	698	708	715	715	705	685	665	646

Correction factor for ΔP ($f_{\Delta P}$)

ΔP (psi)	Correction factor
3	1.00
4	0.87
5	0.79
6	0.72
7	0.66
8	0.62

Correction factor for discharge temperature (T_{disch}).

Discharge temperature	Correction factor
120 $^\circ\text{F}$	0.95
140 $^\circ\text{F}$	0.97
180$^\circ\text{F}$	1.00
200 $^\circ\text{F}$	1.02
210 $^\circ\text{F}$	1.02
230 $^\circ\text{F}$	1.04
250 $^\circ\text{F}$	1.05

Correction factor for liquid temperature (T_{liq}).

Liquid temperature	Correction factor
-10 $^\circ\text{F}$	0.48
10 $^\circ\text{F}$	0.64
30 $^\circ\text{F}$	0.88
50$^\circ\text{F}$	1.00

Nominal capacities

Discharge line

SI units

Capacity table for nominal conditions, Q_N [kW],
 $T_{liq} = 30^\circ\text{C}$,
 $P_{disch} = 8 \text{ bar}$,
 $\Delta P = 0.2 \text{ bar}$
 $T_{disch} = 80^\circ\text{C}$
 Superheat = 8°C

R 134a

Type	Valve body size	K_v (m ³ /h)	Evaporating temperature [°C]						
			-40	-30	-20	-10	0	10	20
ICS25-5	25	1.7	5.1	5.4	5.6	5.9	6.1	6.3	6.5
ICS25-10		3.5	10.6	11.0	11.6	12.0	12.5	13.0	13.4
ICS25-15		6	18.1	19.0	19.8	20.6	21.5	22.3	23.0
ICS25-20		8	24.1	25.3	26.4	27.5	28.6	29.7	30.7
ICS25-25		11.5	34.7	36.0	38.0	39.6	41.0	42.7	44.0
ICS32	32	17	51.0	54.0	56.0	58.5	61.0	63.0	65.0
ICS40	40	27	82.0	85.0	89.0	93.0	97.0	100	104
ICS50	50	44	133	139	145	151	157	163	169
ICS65	65	70	211	221	231	241	251	260	269
ICS80	80	85	256	268	280	293	304	315	326
ICS100	100	142	428	448	469	489	508	527	544
ICS125	125	207	624	654	683	712	741	768	794
ICS150	150	354	1068	1118	1168	1218	1267	1313	1357

Correction factor for ΔP ($f_{\Delta P}$)

ΔP (bar)	Correction factor
0.2	1.00
0.25	0.89
0.3	0.82
0.4	0.71
0.5	0.63
0.6	0.58

Correction factor for discharge temperature (T_{disch}).

Discharge temperature	Correction factor
50°C	0.96
60°C	0.97
80°C	1.00
90°C	1.01
100°C	1.03
110°C	1.04
120°C	1.06

Correction factor for liquid temperature (T_{liq}).

Liquid temperature	Correction factor
-20°C	0.66
-10°C	0.70
0°C	0.76
10°C	0.82
20°C	0.90
30°C	1.00
40°C	1.13
50°C	1.29

US units

Capacity table for nominal conditions, Q_N [Tons of Refrigeration],
 $T_{liq} = 90^\circ\text{F}$,
 $\Delta P = 3 \text{ psi}$
 $P_{disch} = 120 \text{ psi}$,
 $T_{disch} = 180^\circ\text{F}$
 Superheat = 12°F

R 134a

Type	Valve body size	C_v (USgal/min)	Evaporating temperature [°F]						
			-40°F	-20°F	0°F	20°F	40°F	60°F	80°F
ICS25-5	25	2	1.4	1.5	1.5	1.6	1.7	1.7	1.8
ICS25-10		4.1	2.3	3.0	3.1	3.3	3.4	3.6	3.7
ICS25-15		7	4.9	5.1	5.4	5.6	5.9	6.1	6.3
ICS25-20		9.3	6.5	6.8	7.2	7.5	7.8	8.1	8.4
ICS25-25		13.3	9.3	9.8	10.3	10.8	11.3	11.7	12.1
ICS32	32	20	13.8	14.5	15.2	16.0	16.6	17.3	18.0
ICS40	40	31	21.9	23.0	24.2	25.3	26.5	27.5	28.5
ICS50	50	51	35.6	37.5	39.4	41.3	43.0	44.8	46.5
ICS65	65	81	56.7	59.7	62.9	65.7	68.5	71.3	74.0
ICS80	80	98	67	72	75	79	83	86	89
ICS100	100	165	113	121	127	133	139	144	150
ICS125	125	240	164	176	184	194	202	210	218
ICS150	150	410	280	301	315	331	345	358	372

Correction factor for ΔP ($f_{\Delta P}$)

ΔP (psi)	Correction factor
3	1.00
4	0.87
5	0.79
6	0.72
7	0.66
8	0.62

Correction factor for discharge temperature (T_{disch}).

Discharge temperature	Correction factor
120°F	0.95
140°F	0.97
180°F	1.00
200°F	1.02
210°F	1.02
230°F	1.04
250°F	1.05

Correction factor for liquid temperature (T_{liq}).

Liquid temperature	Correction factor
-10°F	0.64
10°F	0.68
30°F	0.74
50°F	0.81
70°F	0.89
90°F	1.00
110°F	1.15
130°F	1.35

Nominal capacities

Discharge line

SI units

Capacity table for nominal conditions, Q_N [kW],
 $T_{liq} = 30^\circ\text{C}$,
 $P_{disch} = 12 \text{ bar}$,
 $\Delta P = 0.2 \text{ bar}$,
 $T_{disch} = 80^\circ\text{C}$,
 Superheat = 8°C

R 404A

Type	Valve body size	K_v (m^3/h)	Evaporating temperature [$^\circ\text{C}$]							
			-50	-40	-30	-20	-10	0	10	20
ICS25-5	25	1.7	4.8	5.1	5.4	5.7	6.0	6.3	6.6	6.8
ICS25-10		3.5	9.8	10.4	11.1	11.8	12.4	13.0	13.6	14.1
ICS25-15		6	16.7	18.0	19.0	20.2	21.3	22.3	23.3	24.2
ICS25-20		8	22.3	24.0	25.4	27.0	28.3	29.7	31.0	32.0
ICS25-25		11.5	32.0	34.0	36.5	38.5	40.7	42.7	44.6	46.0
ICS32	32	17	48.0	51.0	54.0	57.0	60.0	63.0	66.0	69.0
ICS40	40	27	75.0	81.0	86.0	91.0	96.0	100	105	109
ICS50	50	44	123	131	140	148	156	163	171	177
ICS65	65	70	195	208	222	235	248	260	271	282
ICS80	80	85	238	254	270	286	301	315	330	342
ICS100	100	142	397	424	451	477	503	527	551	571
ICS125	125	207	579	618	657	696	733	768	803	833
ICS150	150	354	990	1057	1124	1190	1254	1313	1374	1424

Correction factor for ΔP ($f_{\Delta P}$)

ΔP (bar)	Correction factor
0.2	1.00
0.25	0.89
0.3	0.82
0.4	0.71
0.5	0.63
0.6	0.58

Correction factor for discharge temperature (T_{disch}).

Discharge temperature	Correction factor
50 $^\circ\text{C}$	0.96
60 $^\circ\text{C}$	0.97
80$^\circ\text{C}$	1.00
90 $^\circ\text{C}$	1.01
100 $^\circ\text{C}$	1.03
110 $^\circ\text{C}$	1.04
120 $^\circ\text{C}$	1.06

Correction factor for liquid temperature (T_{liq}).

Liquid temperature	Correction factor
-20 $^\circ\text{C}$	0.55
-10 $^\circ\text{C}$	0.60
0 $^\circ\text{C}$	0.66
10 $^\circ\text{C}$	0.74
20 $^\circ\text{C}$	0.85
30$^\circ\text{C}$	1.00
40 $^\circ\text{C}$	1.23
50 $^\circ\text{C}$	1.68

R 404A

US units

Capacity table for nominal conditions, Q_N [Tons of Refrigeration],
 $T_{liq} = 90^\circ\text{F}$,
 $\Delta P = 3 \text{ psi}$,
 $P_{disch} = 120 \text{ psi}$,
 $T_{disch} = 180^\circ\text{F}$,
 Superheat = 12°F

Type	Valve body size	C_v (USgal/min)	Evaporating temperature [$^\circ\text{F}$]							
			-60 $^\circ\text{F}$	-40 $^\circ\text{F}$	-20 $^\circ\text{F}$	0 $^\circ\text{F}$	20 $^\circ\text{F}$	40 $^\circ\text{F}$	60 $^\circ\text{F}$	80 $^\circ\text{F}$
ICS25-5	25	2	1.2	1.3	1.4	1.5	1.6	1.7	1.8	1.8
ICS25-10		4.1	2.5	2.7	2.9	3.1	3.3	3.5	3.7	3.8
ICS25-15		7	4.4	4.7	5.0	5.4	5.7	6.0	6.3	6.5
ICS25-20		9.3	5.8	6.2	6.7	7.2	7.6	8.0	8.4	8.7
ICS25-25		13.3	8.4	8.9	9.6	10.3	10.9	11.5	12.0	12.5
ICS32	32	20	12.4	13.2	14.2	15.2	16.1	17.0	17.8	18.4
ICS40	40	31	19.6	21.0	22.6	24.1	25.6	27.0	28.2	29.3
ICS50	50	51	32.0	34.2	36.8	39.3	41.7	44.0	46.0	47.7
ICS65	65	81	51.0	54.3	58.5	62.5	66.3	70.0	73.0	76.0
ICS80	80	98	61	65	70	75	80	84	88	91
ICS100	100	165	103	110	118	127	134	142	149	153
ICS125	125	240	149	160	172	184	195	206	216	223
ICS150	150	410	255	273	294	315	334	352	369	381

Correction factor for ΔP ($f_{\Delta P}$)

ΔP (psi)	Correction factor
3	1.00
4	0.87
5	0.79
6	0.72
7	0.66
8	0.62

Correction factor for discharge temperature (T_{disch}).

Discharge temperature	Correction factor
120 $^\circ\text{F}$	0.95
140 $^\circ\text{F}$	0.97
180$^\circ\text{F}$	1.00
200 $^\circ\text{F}$	1.02
210 $^\circ\text{F}$	1.02
230 $^\circ\text{F}$	1.04
250 $^\circ\text{F}$	1.05

Correction factor for liquid temperature (T_{liq}).

Liquid temperature	Correction factor
-10 $^\circ\text{F}$	0.52
10 $^\circ\text{F}$	0.57
30 $^\circ\text{F}$	0.63
50 $^\circ\text{F}$	0.72
70 $^\circ\text{F}$	0.83
90$^\circ\text{F}$	1.00
110 $^\circ\text{F}$	1.29
130 $^\circ\text{F}$	1.92

Nominal capacities

Discharge line

SI units

Capacity table for nominal conditions, Q_N [kW],
 $T_{liq} = 30^\circ\text{C}$,
 $P_{disch} = 12 \text{ bar}$
 $\Delta P = 0.2 \text{ bar}$,
 $T_{disch} = 80^\circ\text{C}$
 Superheat = 8°C

R 22

Type	Valve body size	K_v (m ³ /h)	Evaporating temperature [°C]							
			-50	-40	-30	-20	-10	0	10	20
ICS25-5	25	1.7	6.4	6.6	6.8	7.0	7.2	7.4	7.5	7.7
ICS25-10		3.5	13.2	13.7	14.1	14.5	14.8	15.2	15.5	15.8
ICS25-15		6	22.6	23.4	24.1	24.8	25.4	26.0	26.6	27.1
ICS25-20		8	30.2	31.2	32.1	33.0	33.8	34.6	35.4	36.1
ICS25-25		11.5	43.4	44.9	46.2	47.5	48.6	49.8	50.9	51.9
ICS32	32	17	64.1	66.3	68.2	70.2	71.9	73.6	75.3	76.7
ICS40	40	27	102	105	108	111	114	117	120	122
ICS50	50	44	166	172	177	182	186	190	195	199
ICS65	65	70	264	273	281	289	296	303	310	316
ICS80	80	85	321	331	341	351	359	368	376	384
ICS100	100	142	536	554	570	586	600	615	629	641
ICS125	125	207	781	807	831	855	875	897	917	935
ICS150	150	354	1335	1381	1421	1461	1497	1534	1568	1599

Correction factor for ΔP ($f_{\Delta P}$)

ΔP (bar)	Correction factor
0.2	1.00
0.25	0.89
0.3	0.82
0.4	0.71
0.5	0.63
0.6	0.58

Correction factor for discharge temperature (T_{disch}).

Discharge temperature	Correction factor
50°C	0.96
60°C	0.97
80°C	1.00
90°C	1.01
100°C	1.03
110°C	1.04
120°C	1.06

Correction factor for liquid temperature (T_{liq}).

Liquid temperature	Correction factor
-20°C	0.71
-10°C	0.75
0°C	0.80
10°C	0.86
20°C	0.92
30°C	1.00
40°C	1.09
50°C	1.22

US units

Capacity table for nominal conditions, Q_N [Tons of Refrigeration],
 $T_{liq} = 90^\circ\text{F}$,
 $\Delta P = 3 \text{ psi}$,
 $P_{disch} = 120 \text{ psi}$,
 $T_{disch} = 180^\circ\text{F}$
 Superheat = 12°F

R 22

Type	Valve body size	C_v (USgal/min)	Evaporating temperature [°F]							
			-60°F	-40°F	-20°F	0°F	20°F	40°F	60°F	80°F
ICS25-5	25	2	1.8	1.9	2.0	2.0	2.1	2.1	2.2	2.2
ICS25-10		4.1	3.7	3.9	4.0	4.1	4.3	4.4	4.5	4.6
ICS25-15		7	6.4	6.6	6.8	7.1	7.3	7.4	7.6	7.8
ICS25-20		9.3	8.5	8.8	9.1	9.4	9.6	9.9	10.1	10.3
ICS25-25		13.3	12.1	12.6	13.0	13.4	13.8	14.2	14.5	14.8
ICS32	32	20	18.2	18.9	19.6	20.2	20.7	21.3	21.8	22.2
ICS40	40	31	28.3	29.3	30.3	31.3	32.1	33.0	33.8	34.4
ICS50	50	51	46.5	48.2	49.9	51.4	52.9	54.3	55.5	56.7
ICS65	65	81	73.9	76.6	79.2	81.7	84.0	86.2	88.2	90.0
ICS80	80	98	89	93	96	99	102	104	107	109
ICS100	100	165	150	156	162	166	172	175	180	183
ICS125	125	240	218	227	235	242	250	255	262	267
ICS150	150	410	373	388	402	413	426	436	447	456

Correction factor for ΔP ($f_{\Delta P}$)

ΔP (psi)	Correction factor
3	1.00
4	0.87
5	0.79
6	0.72
7	0.66
8	0.62

Correction factor for discharge temperature (T_{disch}).

Discharge temperature	Correction factor
120°F	0.95
140°F	0.97
180°F	1.00
200°F	1.02
210°F	1.02
230°F	1.04
250°F	1.05

Correction factor for liquid temperature (T_{liq}).

Liquid temperature	Correction factor
-10°F	0.73
10°F	0.77
30°F	0.82
50°F	0.87
70°F	0.93
90°F	1.00
110°F	1.09
130°F	1.20

ICS 25

Ordering from the parts programme

Example (select from table I, II and III)

ICV 25 valve body w/different connections Table I



20 D (3/4 in.)	25 D (1 in.)	32 D (1 1/4 in.)	40 D (1 1/2 in.)
027H2128	027H2120	027H2129	027H2135
35 SD (1 3/8 in. SA)	28 SA (1 1/8 in.)	22 SA (7/8 in.)	28 SD (1 1/8 in.)
027H2134	027H2126	027H2125	027H2124
22 SD (7/8 in.)	20 A (3/4 in.)	25 A (1 in.)	32 A (1 1/4 in.)
027H2123	027H2131	027H2121	027H2130
20 SOC (3/4 in.)	25 SOC (1 in.)	20 FPT (3/4 in.)	25 FPT (1 in.)
027H2132	027H2122	027H2133	027H2127

ICS 25 function module Table II

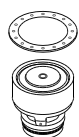

Description	Code Number
ICS 25-5	027H2201 *)
ICS 25-10	027H2202 *)
ICS 25-15	027H2203 *)
ICS 25-20	027H2204 *)
ICS 25-25	027H2200 *)

*) Including gasket and O-rings

ICS 25 top cover Table III

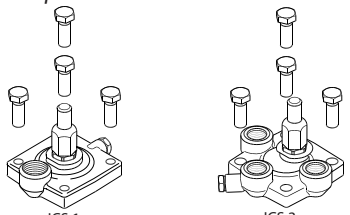

Description	Code Number
Top cover 1 Pilot	027H2172 *)
Top cover 3 Pilots	027H2173 **)

*) Including bolts
**) including bolts and one blanking plug

D = Butt-weld DIN ; A = Butt-weld ANSI ; J = Butt-weld JIS ; SOC = Socket weld ANSI ; SD = Solder DIN ; SA = Solder ANSI ; FPT = Female Pipe Thread

Ordering complete factory assembled valve (body, function module and top cover)

Table A

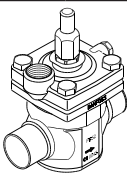
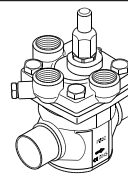
		Available connections							
		20 D (3/4 in.)	25 D (1 in.)	32 D (1 1/4 in.)	40 D (1 1/2 in.)	35 SD (1 3/8 in. SA)	28 SA (1 1/8 in.)	22 SA (7/8 in.)	28 SD (1 1/8 in.)
ICS 25-5	1 Pilot	027H2028	027H2020				027H2026	027H2025	027H2024
	3 Pilots *)	027H2078	027H2070				027H2076	027H2075	027H2074
ICS 25-10	1 Pilot	027H2038	027H2030				027H2036	027H2035	027H2034
	3 Pilots *)	027H2088	027H2080				027H2086	027H2085	027H2084
ICS 25-15	1 Pilot	027H2048	027H2040				027H2046	027H2045	027H2044
	3 Pilots *)	027H2098	027H2090				027H2096	027H2095	027H2094
ICS 25-20	1 Pilot	027H2058	027H2050				027H2056	027H2055	027H2054
	3 Pilots *)	027H2108	027H2100				027H2106	027H2105	027H2104
ICS 25-25	1 Pilot	027H2068	027H2060				027H2066	027H2065	027H2064
	3 Pilots *)	027H2118	027H2110				027H2116	027H2115	027H2114

		22 SD (7/8 in.)	20 A (3/4 in.)	25 A (1 in.)	32 A (1 1/4 in.)	20 SOC (3/4 in.)	25 SOC (1 in.)	20 FPT (3/4 in.)	25 FPT (1 in.)
ICS 25-5	1 Pilot	027H2023	027H2029	027H2021		027H2140			
	3 Pilots *)	027H2073	027H2079	027H2071		027H2145			
ICS 25-10	1 Pilot	027H2033	027H2039	027H2031		027H2141			
	3 Pilots *)	027H2083	027H2089	027H2081		027H2146			
ICS 25-15	1 Pilot	027H2043	027H2049	027H2041		027H2142			
	3 Pilots *)	027H2093	027H2099	027H2091		027H2147			
ICS 25-20	1 Pilot	027H2053	027H2059	027H2051		027H2143			
	3 Pilots *)	027H2103	027H2109	027H2101		027H2148			
ICS 25-25	1 Pilot	027H2063		027H2061			027H2062		
	3 Pilots *)	027H2113		027H2111			027H2112		

Select from parts programme

*) Including one blanking plug (A)

Spare parts and accessories

Spare parts

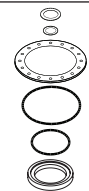

Spare Parts	Code Number
ICS 25 service kit	027H2222

Accessories

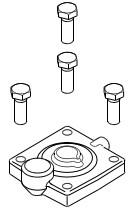

Accessories	Code Number
ICV 25 top cover blind	027H2174 *)

*) Including bolts and gaskets

ICS 32

Ordering from the parts programme

Example (select from table I, II and III)

Valve body 32 D (1 1/4 in.)
027H3120
Table I

Function module ICS 32
027H3200
Table II

Top cover 3 pilots
027H3173
Table III

ICV 32 valve body w/different connections *Table I*

32 D (1 1/4 in.)	40 D (1 1/2 in.)	42 SA (1 5/8 in.)	42 SD (1 5/8 in.)
027H3120	027H3125	027H3127	027H3128
35 SD (1 1/8 in. SA)	32 A (1 1/4 in.)	32 SOC (1 1/4 in.)	40 A (1 1/2 in.)
027H3123	027H3121	027H3122	027H3126

ICS 32 function module *Table II*

Description	Code Number
ICS 32	027H3200 *

*) Including gasket and O-rings

ICS 32 top cover *Table III*

Description	Code Number
Top cover 1 Pilot	027H3172 *
Top cover 3 Pilots	027H3173 **)

*) Including bolts
**) including bolts and one blanking plug

D = Butt-weld DIN ; A = Butt-weld ANSI ; J = Butt-weld JIS ; SOC = Socket weld ANSI ; SD = Solder DIN ; SA = Solder ANSI ; FPT = Female Pipe Thread

Ordering complete factory assembled valve (body, function module and top cover)

Table A

		Available connections							
		32 D (1 1/4 in.)	40 D (1 1/2 in.)	42 SA (1 5/8 in.)	42 SD (1 5/8 in.)	35 SD (1 1/8 in. SA)	32 A (1 1/4 in.)	32 SOC (1 1/4 in.)	40 A (1 1/2 in.)
ICS 32	1 Pilot	027H3020				027H3023	027H3021	027H3022	
	3 Pilots *)	027H3030				027H3033	027H3031	027H3032	

Select from parts programme
*) Including one blanking plug (A)

Spare parts and accessories

Spare parts

Spare Parts	Code Number
ICS 32 service kit	027H3222

Accessories

Accessories	Code Number
ICV 32 top cover blind	027H3174 *)

*) Including bolts and gaskets

ICS 40

Ordering from the parts programme

Example (select from table I, II and III)

Valve body 50 D (2 in.)
027H4126
Table I

Function module ICS 40
027H4200
Table II

Top cover 1 pilot
027H4172
Table III

ICV 40 valve body w/different connections Table I

40 D (1½ in.)	50 D (2 in.)	42 SA (1⅝ in.)	42 SD (1⅝ in.)
027H4120	027H4126	027H4124	027H4123
40 A (1½ in.)	40 SOC (1½ in.)	50 A (2 in.)	
027H4121	027H4122	027H4127	

ICS 40 function module Table II

Description	Code Number
ICS 40	027H4200 *

**) Including gasket and O-rings*

ICS 40 top cover Table III

Description	Code Number
Top cover 1 Pilot	027H4172 *
Top cover 3 Pilots	027H4173 **)

**) Including bolts*
****) including bolts and one blanking plug*

D = Butt-weld DIN ; A = Butt-weld ANSI ; J = Butt-weld JIS ; SOC = Socket weld ANSI ; SD = Solder DIN ; SA = Solder ANSI ; FPT = Female Pipe Thread

Ordering complete factory assembled valve (body, function module and top cover)

Table A

		Available connections						
		40 D (1½ in.)	50 D (2 in.)	42 SA (1⅝ in.)	42 SD (1⅝ in.)	40 A (1½ in.)	40 SOC (1½ in.)	50 A (2 in.)
ICS 40	1 Pilot	027H4020		027H4024	027H4023	027H4021	027H4022	
	3 Pilots *)	027H4030		027H4034	027H4033	027H4031	027H4032	

Select from parts programme

**) Including one blanking plug (A)*

Spare parts and accessories

Spare parts

Spare Parts	Code Number
ICS 40 service kit	027H4222

Accessories

Accessories	Code Number
ICV 40 top cover blind	027H4174 *)

**) Including bolts and gaskets*

ICS 50

Ordering from the parts programme

Example (select from table I, II and III)

Valve body 65 D (2 1/2 in.)
027H5124
Table I

Function module ICS 40
027H5200
Table II

Top cover 1 pilot
027H5172
Table III

ICV 50 valve body w/different connections *Table I*

50 D (2 in.)	65 D (2 1/2 in.)	54 SD (2 1/8 in. SA)	50 A (2 in.)
027H5120	027H5124	027H5123	027H5121
50 SOC (2 in.)	65 A (2 1/2 in.)		
027H5122	027H5125		

ICS 50 function module *Table II*

Description	Code Number
ICS 50	027H5200 *

*) Including gasket and O-rings

ICS 50 top cover *Table III*

Description	Code Number
Top cover 1 Pilot	027H5172 *
Top cover 3 Pilots	027H5173 **

*) Including bolts
**) including bolts and one blanking plug

D = Butt-weld DIN ; A = Butt-weld ANSI ; J = Butt-weld JIS ; SOC = Socket weld ANSI ; SD = Solder DIN ; SA = Solder ANSI ; FPT = Female Pipe Thread

Ordering complete factory assembled valve (body, function module and top cover)

Table A

		Available connections					
		50 D (2 in.)	65 D (2 1/2 in.)	54 SD (2 1/8 in. SA)	65 A (2 1/2 in.)	50 A (2 in.)	50 SOC (2 in.)
ICS 50	1 Pilot	027H5020		027H5023		027H5021	027H5022
	3 Pilots *)	027H5030		027H5033		027H5031	027H5032

Select from parts programme

*) Including one blanking plug (A)

Spare parts and accessories

Spare parts

Spare Parts	Code Number
ICS 50 service kit	027H5222

Accessories

Accessories	Code Number
ICV 50 top cover blind	027H5174 *)

*) Including bolts and gaskets

ICS 65 and ICS 80

Ordering from the parts programme

Example (select from table I, II and III)

Valve body 76 SD (2 5/8 in.)
027H6124
Table I

Function module
ICS 65 **027H6200**
ICS 80 **027H8200**
Table II

Top cover 3 pilots
027H6173
Table III

ICV 65 valve body w/different connections *Table I*

65 D (2 1/2 in.)	65 A (2 1/2 in.)	65 J (2 1/2 in.)	80 D (3 in.)
027H6120	027H6121	027H6122	027H6126
80 A (3 in.)	67 SA (2 5/8 in.)	76 SD (3 in.)	65 SOC (2 1/2 in.)
027H6127	027H6125	027H6124	027H6123

ICS 65 and ICS 80 function module *Table II*

Description	Code Number
ICS 65	027H6200 *
ICS 80	027H8200 *

*) Including gasket and O-rings

ICS 65 top cover *Table III*

Description	Code Number
Top cover 1 Pilot	027H6172 *
Top cover 3 Pilots	027H6173 **

*) Including bolts
**) including bolts and one blanking plug

D = Butt-weld DIN ; A = Butt-weld ANSI ; J = Butt-weld JIS ; SOC = Socket weld ANSI ; SD = Solder DIN ; SA = Solder ANSI ; FPT = Female Pipe Thread

Ordering complete factory assembled valve (body, function module and top cover)

Table A

		Available connections							
		65 D (2 1/2 in.)	65 A (2 1/2 in.)	65 SOC (2 1/2 in.)	80 D (3 in.)	80 A (3 in.)	67 SA (2 5/8 in.)	76 SD (3 in.)	65 J (2 1/2 in.)
ICS 65	1 Pilot	027H6020	027H6021	027H6023			027H6025	027H6024	
	3 Pilots *)	027H6030	027H6031	027H6033			027H6035	027H6034	
ICS 80	1 Pilot				027H8020	027H8021			
	3 Pilots *)				027H8030	027H8031			

Select from parts programme

*) Including one blanking plug (A)



Note:

The capacity of the ICS 80 module can only be achieved when using the valve body with 80 D or A (3 in) connections. If any other ICV 65 valve body is used the capacity of the complete valve will be reduced by approximately 6%.

Spare parts and accessories

Spare parts

Spare Parts	Code Number
ICS 65 service kit	027H6222
ICS 80 service kit	027H8222

Accessories

Accessories	Code Number
ICV 65 top cover blind	027H6174 *)

*) Including bolts and gaskets

ICS 100 - 150

Ordering complete factory assembled valve
(body, function module and top cover)

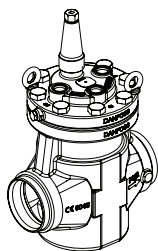

ICS 100 *)

Connections		
100 D (4 in.)	100 A (4 in.)	100 A (4 in.) with 3/8" NPT pressure outlet
027H7120	027H7121	027H7122

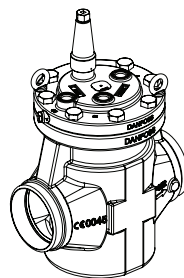

ICS 125 *)

Connections		
125 D (5 in.)	125 A (5 in.)	125 A (5 in.) with 3/8" NPT pressure outlet
027H7140	027H7141	027H7142

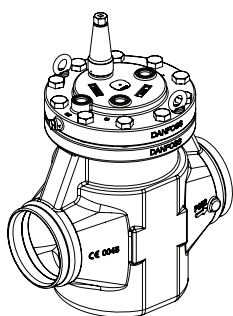

ICS 150 *)

Connections		
150 D (6 in.)	150 A (6 in.)	150 A (6 in.) with 3/8" NPT pressure outlet
027H7160	027H7161	027H7162

*) Including two blanking plugs (A) and one sealing plug (B)

Accessories

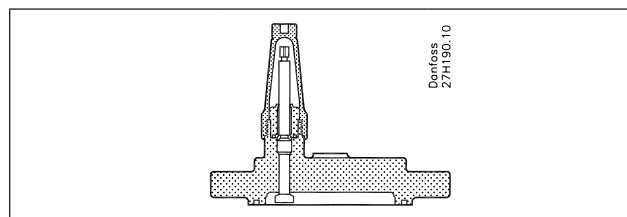

Top covers		
Consist of:	Size	Code number
Top cover complete with manual spindle, and gasket	ICS 100	027H7123
	ICS 125	027H7143
	ICS 150	027H7163

Spare parts

Inspection set A		
Consist of:	Size	Code number
Gasket (pos. 2)	ICS 100	027H7124
O-ring (pos. 3 and pos. 4)	ICS 125	027H7144
Alu gasket for pressure gauge	ICS 150	027H7164
Gasket for pilot		
O-ring for pilot		

Maintenance set B		
Consist of:	Size	Code number
Inspection set A	ICS 100	027H7125
Valve plate (pos. 5)	ICS 125	027H7145
Piston ring (pos. 6)	ICS 150	027H7165

Replacement set C		
Consist of:	Size	Code number
Gasket (pos. 2)	ICS 100	027H7126
Function module (pos. 1)	ICS 125	027H7146
Alu gasket for pressure gauge	ICS 150	027H7166
Gasket for pilot		
O-ring for pilot		

Caps D		
Consist of:	Size	Code number
Cap (pos. 7)	ICS 100-150	148B4076
Packing gland	ICS 100-150	148B4138

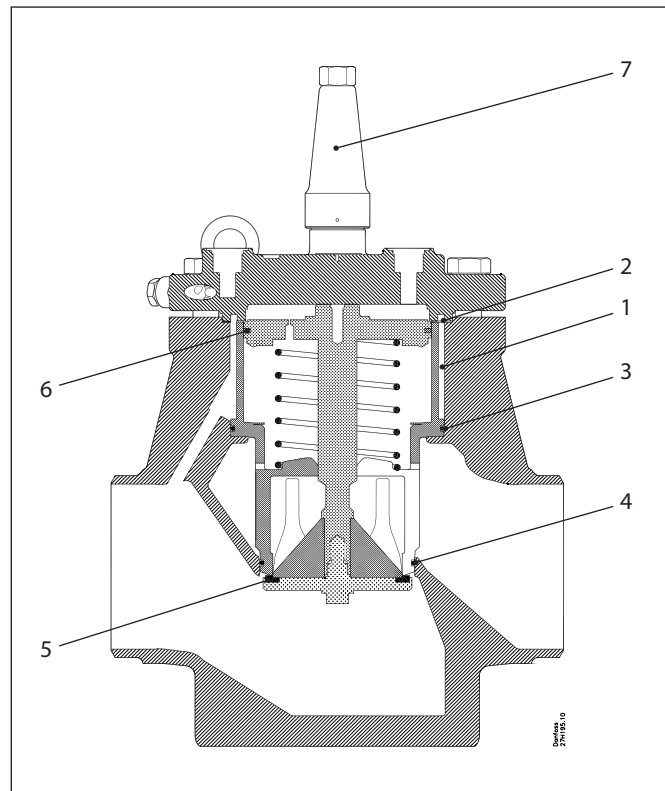

Accessories

Pressure gauge connection (weld / solder).

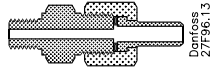

Description	Code no.
∅ 6.5 mm / ∅ 10 mm (∅ 0.26 in. / ∅ 0.39 in.) weld / solder	027B2035

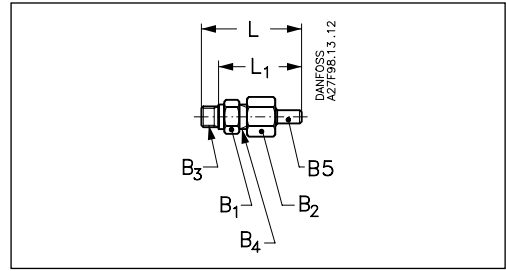

Accessories		L	L ₁	B ₁	B ₂	B ₃	B ₄	B ₅
-------------	--	---	----------------	----------------	----------------	----------------	----------------	----------------

Pressure gauge connection (weld / solder)

	mm	66	54	AF 19	AF 22	G 1/4 A	G 3/8 A	∅6.5 / ∅10
	in.	2.60	2.13					

Pressure gauge connection, 1/4 in. flare (self-closing)
Must not be used in R 717 plant.

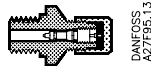

Description	Code no.
1/4 in. flare	027B2041

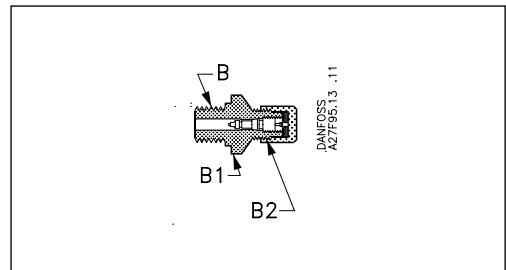

Accessories						B	B ₁	B ₂
-------------	--	--	--	--	--	---	----------------	----------------

Pressure gauge connection, 1/4 in. flare (self-closing)

1/4 in. flare	mm					G 1/4 A	AF 19	1/4 in. flare
	in.							

Pressure gauge connection (cutting ring).

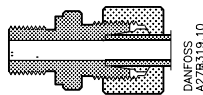

Description	Code no.
Cutting ring connection, 6 mm	027B2063
Cutting ring connection, 10 mm	027B2064

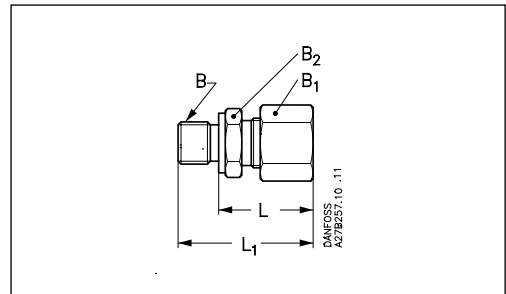

Accessories			L	L ₁		B	B ₁	B ₂
-------------	--	--	---	----------------	--	---	----------------	----------------

Pressure gauge connection (cutting ring)

6 mm	mm		27	39		G 1/4 A	AF 19	AF 14
	in.		1.06	1.54				
10 mm	mm		29	40		G 1/4 A	AF 19	AF 14
	in.		1.14	1.57				

Multi-function tool

Description	Code no.
Multi-function tool for ICS 25-65	027H0180 / 027H0181

The multi-function tool can be used for:

- Removing the ICS function module
- Operating the manual spindle

For further information please see the instruction PIHU0A.



Accessories
(continued)

Pressure gauge connection.

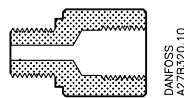

Description	Code no.
1/4 FPT	027B2062

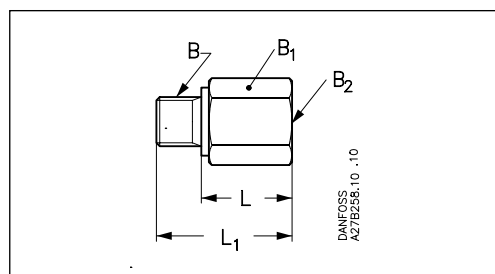

Accessories			L	L ₁		B	B ₁	B ₂
	mm		23	35.5		G 1/4 A	AF 22	1/4 FPT
	in.		0.91	1.40				

Pressure gauge connection

	mm		23	35.5		G 1/4 A	AF 22	1/4 FPT
	in.		0.91	1.40				

External pilot connection.



ICS	Description	Code no.
5 - 80	External pilot connection (incl. damping orifice, D: 1.0 mm)	027F1048
5 - 150	Accessory bag with seal and O-ring for pilot valve	027F0666
100 - 150	External pilot connection (incl. damping orifice, D: 1.8 mm)	027F1049

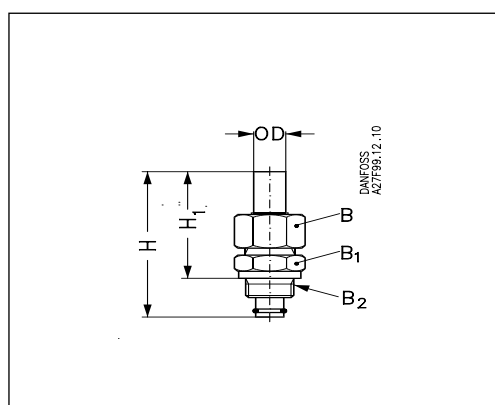

Accessories			H	H ₁	OD	B	B ₁	B ₂
	mm		90	66	18	AF 32	AF 32	M 24 x 1.5
	in.		3.54	2.60	0.71			

External pilot connection

	mm		90	66	18	AF 32	AF 32	M 24 x 1.5
	in.		3.54	2.60	0.71			

Blanking plug for pilot valves.



Description	Code no.
Blanking plug	027F1046

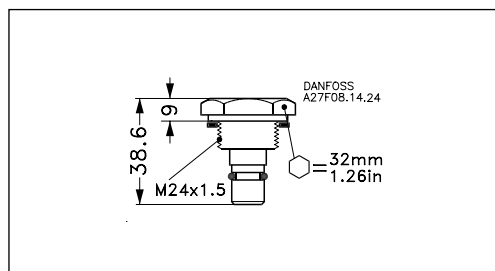

Recommended filters							Filter element for liquid line		Filter element for suction line	
							150 mesh	100 mesh	72 mesh	38 mesh
	Filter Type	Size	D	A	FPT	SOC	100 my	150 my	250 my	500 my
	FIA Straightway	20 (3/4 in.)	148H3086	148H3098	148H3116	148H3110	148H3122	148H3124	148H3126	148H3128
	FIA Straightway	25 (1 in.)	148H3087	148H3099	148H3117	148H3111	148H3123	148H3125	148H3127	148H3129
	FIA Straightway	32 (1 1/4 in.)	148H3088	148H3100	148H3118	148H3112	148H3123	148H3125	148H3127	148H3129
	FIA Straightway	40 (1 1/2 in.)	148H3089	148H3101		148H3113	148H3123	148H3125	148H3127	148H3129
	FIA Straightway	50 (2 in.)	148H3090	148H3102		148H3114	148H3157	148H3130	148H3138	148H3144
	FIA Straightway	65 (2 1/2 in.)	148H3091	148H3103				148H3131	148H3139	148H3145
	FIA Straightway	80 (3 in.)	148H3092	148H3104				148H3119	148H3120	148H3121
	FIA Straightway	100 (4 in.)	148H3093	148H3105				148H3132	148H3140	148H3146
	FIA Straightway	125 (5 in.)	148H3094	148H3106				148H3133	148H3141	148H3147
FIA Straightway	150 (6 in.)	148H3095	148H3107				148H3134	148H3142	148H3226	

Dimensions and weights - ICS 25-5 to ICS 25-25

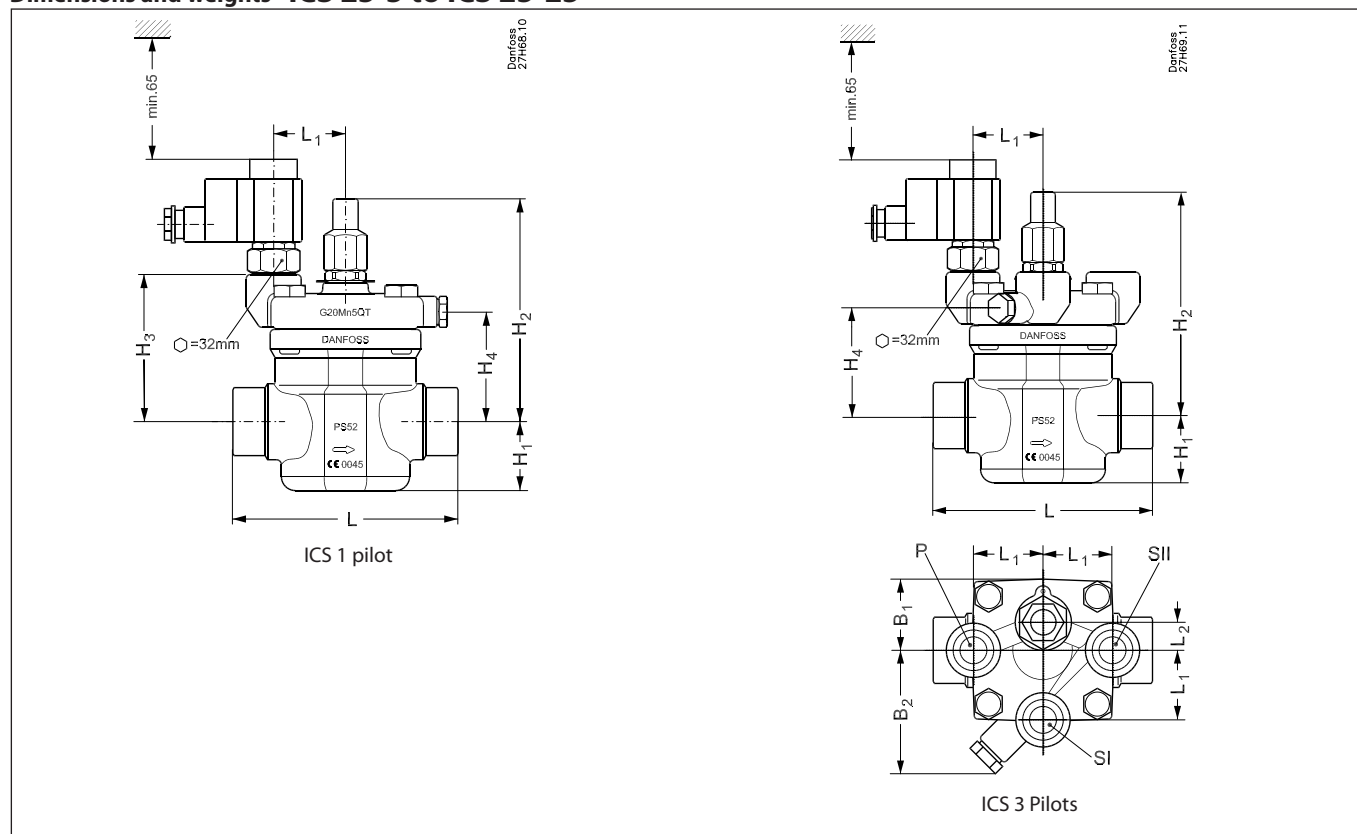

Connection		H ₁	H ₂	H ₃	H ₄	L	L ₁	L ₂	B ₁	B ₂	Weight ICS 1 Pilot	Weight ICS 3 Pilots
20 D (3/4 in.)	mm	37	138	86	60	135	51	15	42	87	3 kg	3.6 kg
	in.	1.46	5.43	3.39	2.36	5.31	2.00	0.59	1.65	3.43	6.6 lb.	7.92 lb.
25 D (1 in.)	mm	37	138	86	60	135	51	15	42	87	3 kg	3.6 kg
	in.	1.46	5.43	3.39	2.36	5.31	2.00	0.59	1.65	3.43	6.6 lb.	7.92 lb.
32 D (1 1/4 in.)	mm	37	138	86	60	135	51	15	42	87	3 kg	3.6 kg
	in.	1.46	5.43	3.39	2.36	5.31	2.00	0.59	1.65	3.43	6.6 lb.	7.92 lb.
40 D (1 1/2 in.)	mm	37	138	86	60	135	51	15	42	87	3 kg	3.6 kg
	in.	1.46	5.43	3.39	2.36	5.31	2.00	0.59	1.65	3.43	6.6 lb.	7.92 lb.
20 A (3/4 in.)	mm	37	138	86	60	135	51	15	42	87	3 kg	3.6 kg
	in.	1.46	5.43	3.39	2.36	5.31	2.00	0.59	1.65	3.43	6.6 lb.	7.92 lb.
25 A (1 in.)	mm	37	138	86	60	135	51	15	42	87	3 kg	3.6 kg
	in.	1.46	5.43	3.39	2.36	5.31	2.00	0.59	1.65	3.43	6.6 lb.	7.92 lb.
32 A (1 1/4 in.)	mm	37	138	86	60	135	51	15	42	87	3 kg	3.6 kg
	in.	1.46	5.43	3.39	2.36	5.31	2.00	0.59	1.65	3.43	6.6 lb.	7.92 lb.
20 SOC (3/4 in.)	mm	37	138	86	60	135	51	15	42	87	3 kg	3.6 kg
	in.	1.46	5.43	3.39	2.36	5.31	2.00	0.59	1.65	3.43	6.6 lb.	7.92 lb.
25 SOC (1 in.)	mm	37	138	86	60	147	51	15	42	87	3 kg	3.6 kg
	in.	1.46	5.43	3.39	2.36	5.79	2.00	0.59	1.65	3.43	6.6 lb.	7.92 lb.
22 SD (7/8 in.)	mm	37	138	86	60	135	51	15	42	87	3 kg	3.6 kg
	in.	1.46	5.43	3.39	2.36	5.31	2.00	0.59	1.65	3.43	6.6 lb.	7.92 lb.
28 SD (1 1/8 in.)	mm	37	138	86	60	147	51	15	42	87	3 kg	3.6 kg
	in.	1.46	5.43	3.39	2.36	5.78	2.00	0.59	1.65	3.43	6.6 lb.	7.92 lb.
22 SA (7/8 in.)	mm	37	138	86	60	135	51	15	42	87	3 kg	3.6 kg
	in.	1.46	5.43	3.39	2.36	5.31	2.00	0.59	1.65	3.43	6.6 lb.	7.92 lb.
28 SA (1 1/8 in.)	mm	37	138	86	60	147	51	15	42	87	3 kg	3.6 kg
	in.	1.46	5.43	3.39	2.36	5.78	2.00	0.59	1.65	3.43	6.6 lb.	7.92 lb.
35 SA (1 3/8 in.)	mm	37	138	86	60	147	51	15	42	87	3 kg	3.6 kg
	in.	1.46	5.43	3.39	2.36	5.78	2.00	0.59	1.65	3.43	6.6 lb.	7.92 lb.
20 FPT (3/4 in.)	mm	37	138	86	60	135	51	15	42	87	3 kg	3.6 kg
	in.	1.46	5.43	3.39	2.36	5.31	2.00	0.59	1.65	3.43	6.6 lb.	7.92 lb.
25 FPT (1 in.)	mm	37	138	86	60	135	51	15	42	87	3 kg	3.6 kg
	in.	1.46	5.43	3.39	2.36	5.31	2.00	0.59	1.65	3.43	6.6 lb.	7.92 lb.

D = Butt-weld DIN ; A = Butt-weld ANSI ; J = Butt-weld JIS ; SOC = Socket weld ANSI ; SD = Solder DIN ; SA = Solder ANSI ; FPT = Female Pipe Thread

Dimensions and weights - ICS 32

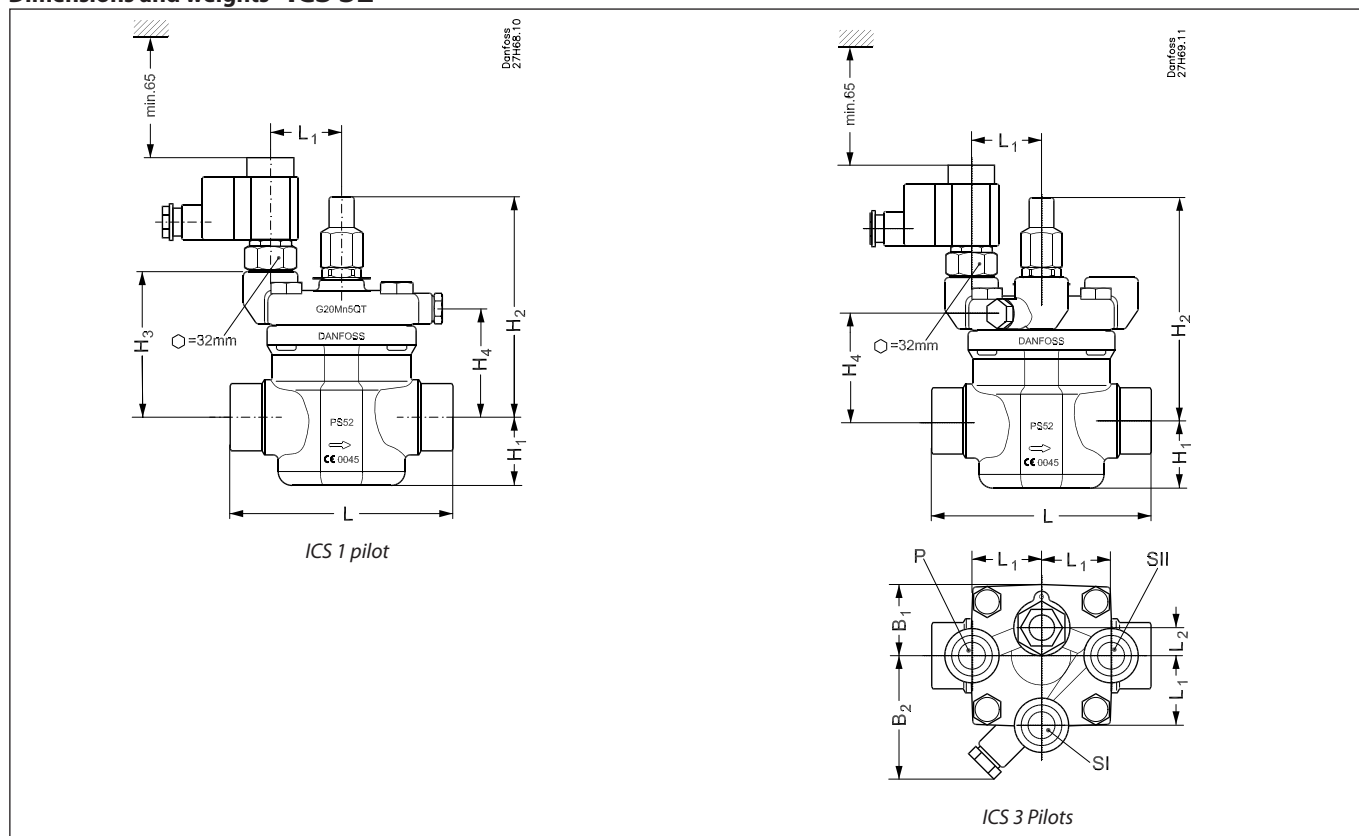

Connection		H ₁	H ₂	H ₃	H ₄	L	L ₁	L ₂	B ₁	B ₂	Weight ICS 1 Pilot	Weight ICS 3 Pilots
32 D (1¼ in.)	mm	40	153	100	74	145	51	15	51	87	4.5 kg	5 kg
	in.	1.57	6.02	3.93	2.91	5.71	2.00	0.59	2.00	3.43	9.9 lb.	11 lb.
40 D (1½ in.)	mm	40	153	100	74	145	51	15	51	87	4.5 kg	5 kg
	in.	1.57	6.02	3.93	2.91	5.71	2.00	0.59	2.00	3.43	9.9 lb.	11 lb.
32 A (1¼ in.)	mm	40	153	100	74	145	51	15	51	87	4.5 kg	5 kg
	in.	1.57	6.02	3.93	2.91	5.71	2.00	0.59	2.00	3.43	9.9 lb.	11 lb.
40 A (1½ in.)	mm	40	153	100	74	145	51	15	51	87	4.5 kg	5 kg
	in.	1.57	6.02	3.93	2.91	5.71	2.00	0.59	2.00	3.43	9.9 lb.	11 lb.
32 SOC (1¼ in.)	mm	40	153	100	74	148	51	15	51	87	4.5 kg	5 kg
	in.	1.57	6.02	3.93	2.91	5.83	2.00	0.59	2.00	3.43	9.9 lb.	11 lb.
35 SD (1⅜ in. SA)	mm	40	153	100	74	148	51	15	51	87	4.5 kg	5 kg
	in.	1.57	6.02	3.93	2.91	5.83	2.00	0.59	2.00	3.43	9.9 lb.	11 lb.
42 SD (1⅝ in.)	mm	40	153	100	74	148	51	15	51	87	4.5 kg	5 kg
	in.	1.57	6.02	3.93	2.91	5.83	2.00	0.59	2.00	3.43	9.9 lb.	11 lb.
42 SA (1⅝ in.)	mm	40	153	100	74	148	51	15	51	87	4.5 kg	5 kg
	in.	1.57	6.02	3.93	2.91	5.83	2.00	0.59	2.00	3.43	9.9 lb.	11 lb.

D = Butt-weld DIN ; A = Butt-weld ANSI ; J = Butt-weld JIS ; SOC = Socket weld ANSI ; SD = Solder DIN ; SA = Solder ANSI ; FPT = Female Pipe Thread

Dimensions and weights - ICS 40

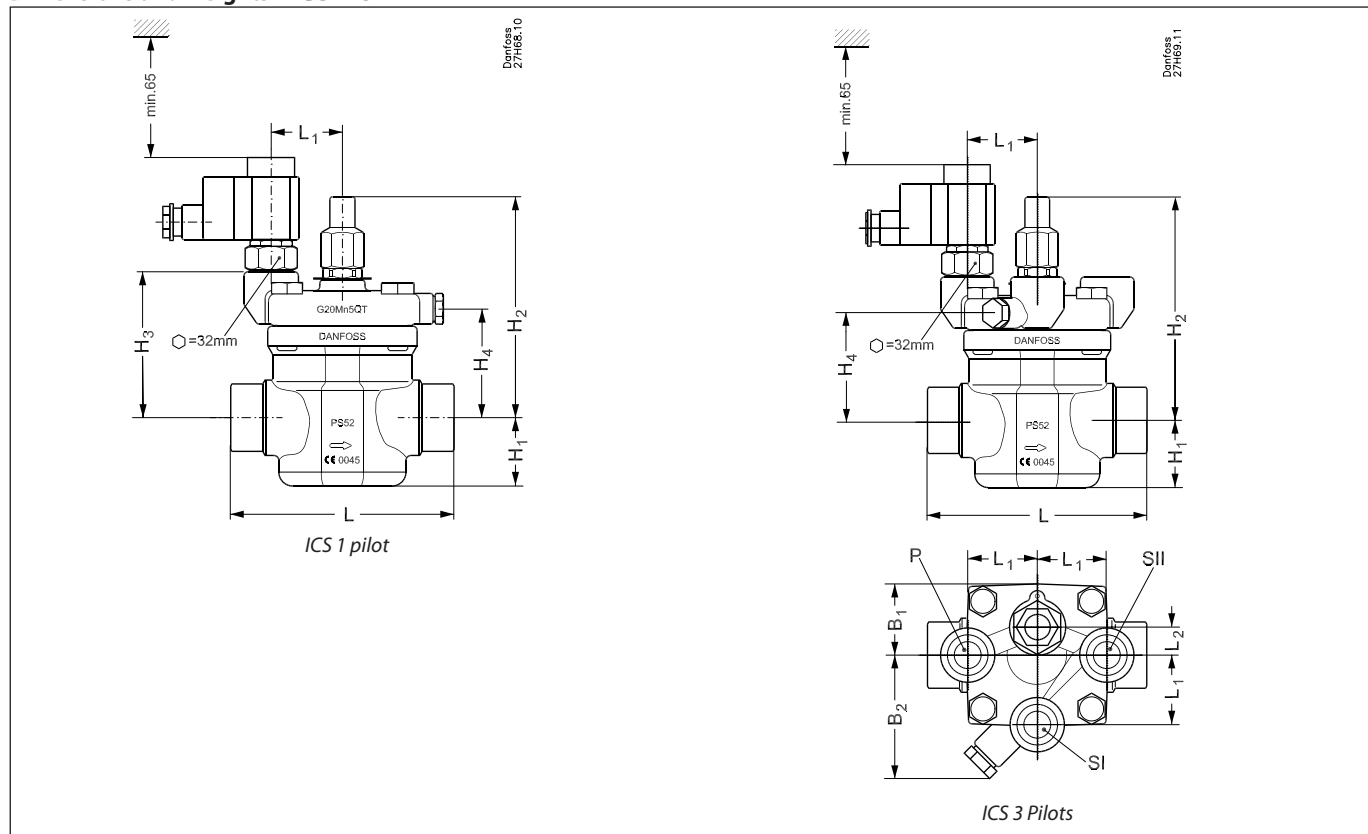

Connection		H ₁	H ₂	H ₃	H ₄	L	L ₁	L ₂	B ₁	B ₂	Weight ICS 1 Pilot	Weight ICS 3 Pilots
40 D (1½ in.)	mm	49	159	105	78	160	51	15	54	87	5.9 kg	6.3 kg
	in.	1.93	6.26	4.13	3.07	6.30	2.00	0.59	2.13	3.43	13.0 lb.	13.9 lb.
50 D (2 in.)	mm	49	159	105	78	180	51	15	54	87	5.9 kg	6.3 kg
	in.	1.93	6.26	4.13	3.07	7.09	2.00	0.59	2.13	3.43	13.0 lb.	13.9 lb.
40 A (1½ in.)	mm	49	159	105	78	160	51	15	54	87	5.9 kg	6.3 kg
	in.	1.93	6.26	4.13	3.07	6.30	2.00	0.59	2.13	3.43	13.0 lb.	13.9 lb.
50 A (2 in.)	mm	49	159	105	78	180	51	15	54	87	5.9 kg	6.3 kg
	in.	1.93	6.26	4.13	3.07	7.09	2.00	0.59	2.13	3.43	13.0 lb.	13.9 lb.
40 SOC (1½ in.)	mm	49	159	105	78	180	51	15	54	87	5.9 kg	6.3 kg
	in.	1.93	6.26	4.13	3.07	7.09	2.00	0.59	2.13	3.43	13.0 lb.	13.9 lb.
42 SD (1⅝ in.)	mm	49	159	105	78	180	51	15	54	87	5.9 kg	6.3 kg
	in.	1.93	6.26	4.13	3.07	7.09	2.00	0.59	2.13	3.43	13.0 lb.	13.9 lb.
42 SA (1⅝ in.)	mm	49	159	105	78	180	51	15	54	87	5.9 kg	6.3 kg
	in.	1.93	6.26	4.13	3.07	7.09	2.00	0.59	2.13	3.43	13.0 lb.	13.9 lb.

D = Butt-weld DIN ; A = Butt-weld ANSI ; J = Butt-weld JIS ; SOC = Socket weld ANSI ; SD = Solder DIN ; SA = Solder ANSI ; FPT = Female Pipe Thread

Dimensions and weights - ICS 50

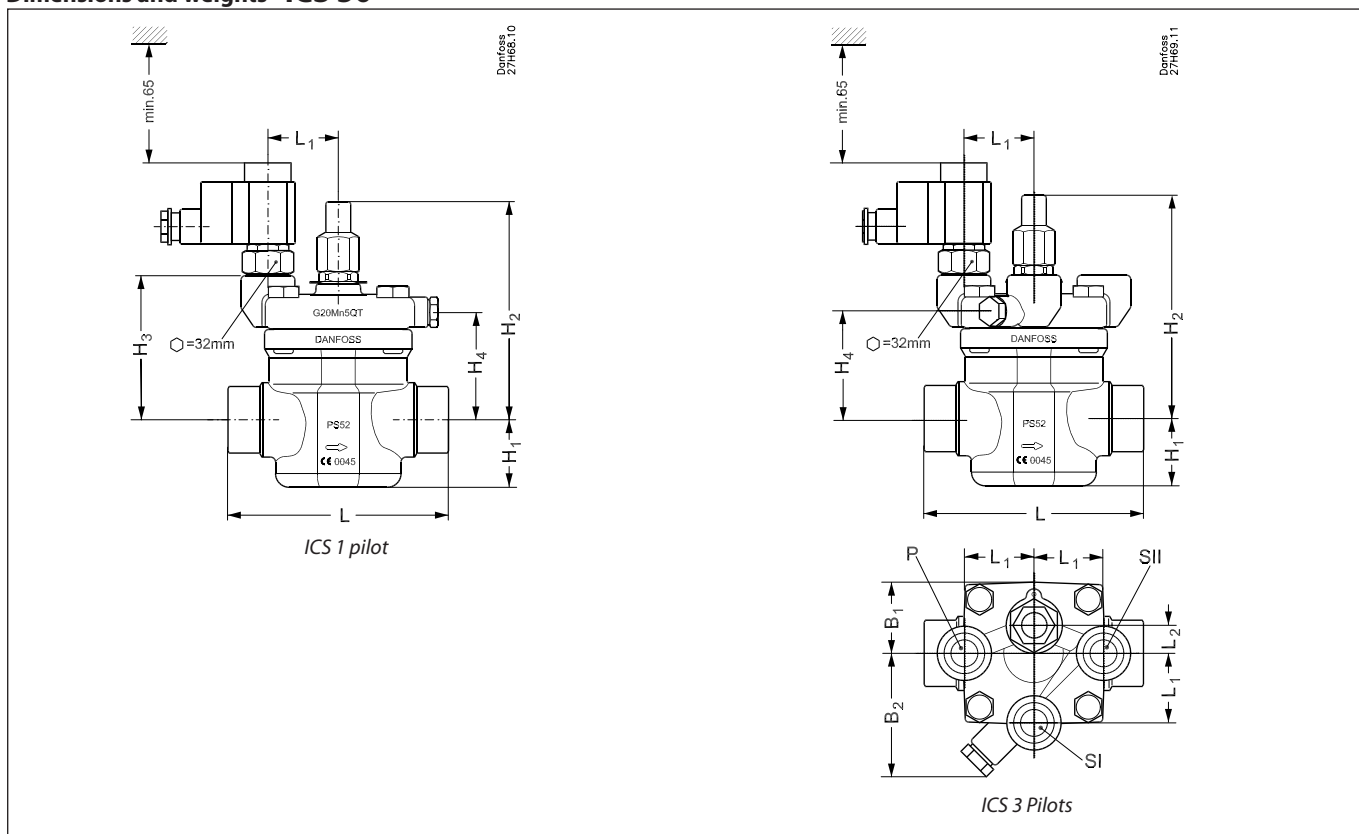

Connection		H ₁	H ₂	H ₃	H ₄	L	L ₁	L ₂	B ₁	B ₂	Weight ICS 1 Pilot	Weight ICS 3 Pilots
50 D (2 in.)	mm	59	174	120	93	200	51	15	63	91	8.9 kg	9.2 kg
	in.	2.32	6.85	4.72	3.66	7.87	2.00	0.59	2.48	3.58	19.6 lb.	20.2 lb.
65 D (2½ in.)	mm	59	174	120	93	210	51	15	63	91	8.9 kg	9.2 kg
	in.	2.32	6.85	4.72	3.66	8.27	2.00	0.59	2.48	3.58	19.6 lb.	20.2 lb.
50 A (2 in.)	mm	59	174	120	93	200	51	15	63	91	8.9 kg	9.2 kg
	in.	2.32	6.85	4.72	3.66	7.87	2.00	0.59	2.48	3.58	19.6 lb.	20.2 lb.
65 A (2½ in.)	mm	59	174	120	93	210	51	15	63	91	8.9 kg	9.2 kg
	in.	2.32	6.85	4.72	3.66	8.27	2.00	0.59	2.48	3.58	19.6 lb.	20.2 lb.
50 SOC (2 in.)	mm	59	174	120	93	216	51	15	63	91	8.9 kg	9.2 kg
	in.	2.32	6.85	4.72	3.66	8.50	2.00	0.59	2.48	3.58	19.6 lb.	20.2 lb.
54 SD (2⅛ in. SA)	mm	59	174	120	93	216	51	15	63	91	8.9 kg	9.2 kg
	in.	2.32	6.85	4.72	3.66	8.50	2.00	0.59	2.48	3.58	19.6 lb.	20.2 lb.

D = Butt-weld DIN ; A = Butt-weld ANSI ; J = Butt-weld JIS ; SOC = Socket weld ANSI ; SD = Solder DIN ; SA = Solder ANSI ; FPT = Female Pipe Thread

Dimensions and weights - ICS 65

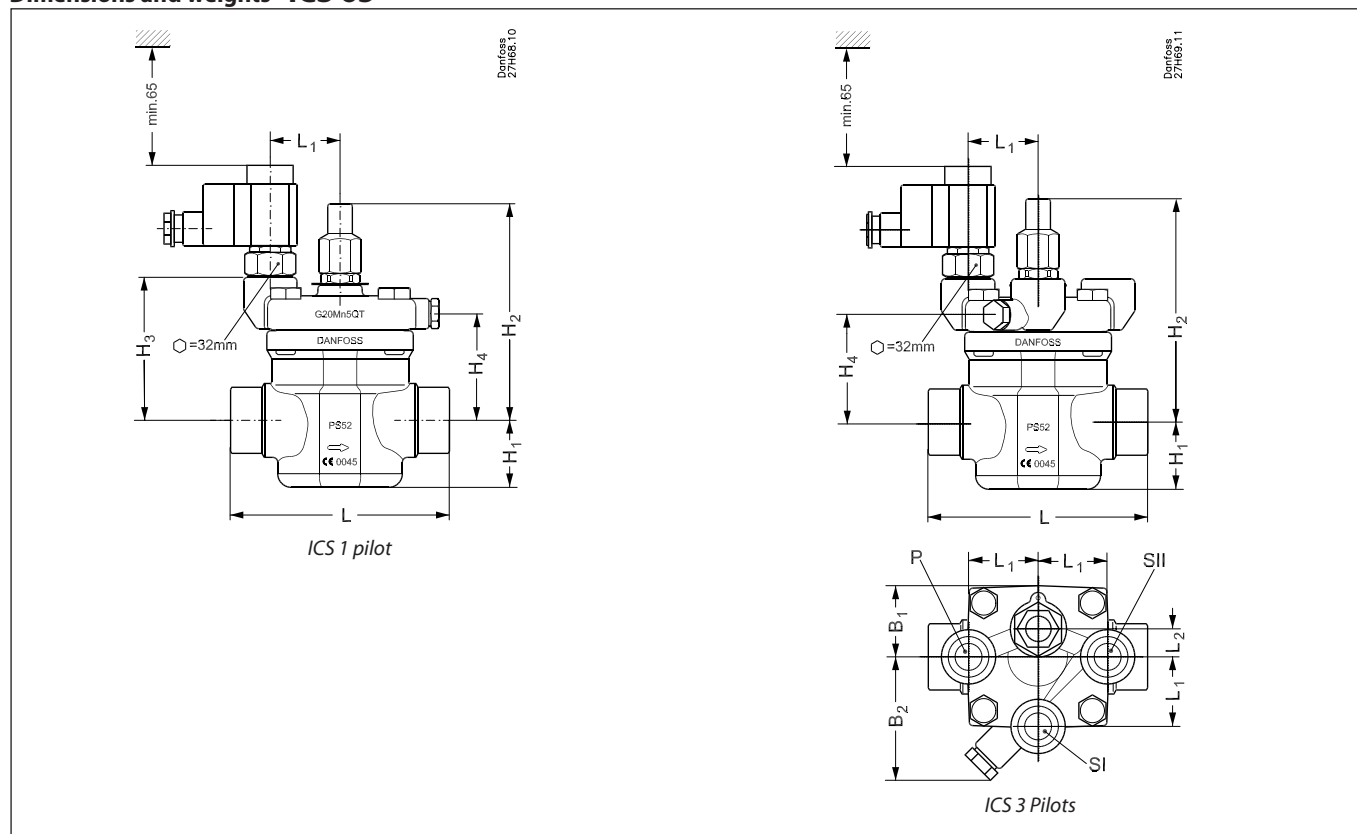

Connection		H ₁	H ₂	H ₃	H ₄	L	L ₁	L ₂	B ₁	B ₂	Weight ICS 1 Pilot	Weight ICS 3 Pilots
65 D (2 1/2 in.)	mm	65	195	140	115	230	51	15	70	91	13.4 kg	13.5 kg
	in.	2.56	7.68	5.51	4.53	9.06	2.00	0.59	2.76	3.58	29.48 lb.	29.7 lb.
65 A (2 1/2 in.)	mm	65	195	140	115	230	51	15	70	91	13.4 kg	13.5 kg
	in.	2.56	7.68	5.51	4.53	9.06	2.00	0.59	2.76	3.58	29.48 lb.	29.7 lb.
65 J (2 1/2 in.)	mm	65	195	140	115	230	51	15	70	91	13.4 kg	13.5 kg
	in.	2.56	7.68	5.51	4.53	9.06	2.00	0.59	2.76	3.58	29.48 lb.	29.7 lb.
65 SOC (2 1/2 in.)	mm	65	195	140	115	230	51	15	70	91	13.4 kg	13.5 kg
	in.	2.56	7.68	5.51	4.53	9.06	2.00	0.59	2.76	3.58	29.48 lb.	29.7 lb.
76 SD (3 in.)	mm	65	195	140	115	245	51	15	70	91	13.4 kg	13.5 kg
	in.	2.56	7.68	5.51	4.53	9.65	2.00	0.59	2.76	3.58	29.48 lb.	29.7 lb.
67 SA (2 5/8 in.)	mm	65	195	140	115	245	51	15	70	91	13.4 kg	13.5 kg
	in.	2.56	7.68	5.51	4.53	9.65	2.00	0.59	2.76	3.58	29.48 lb.	29.7 lb.

D = Butt-weld DIN ; A = Butt-weld ANSI ; J = Butt-weld JIS ; SOC = Socket weld ANSI ; SD = Solder DIN ; SA = Solder ANSI ; FPT = Female Pipe Thread

Dimensions and weights - ICS 100

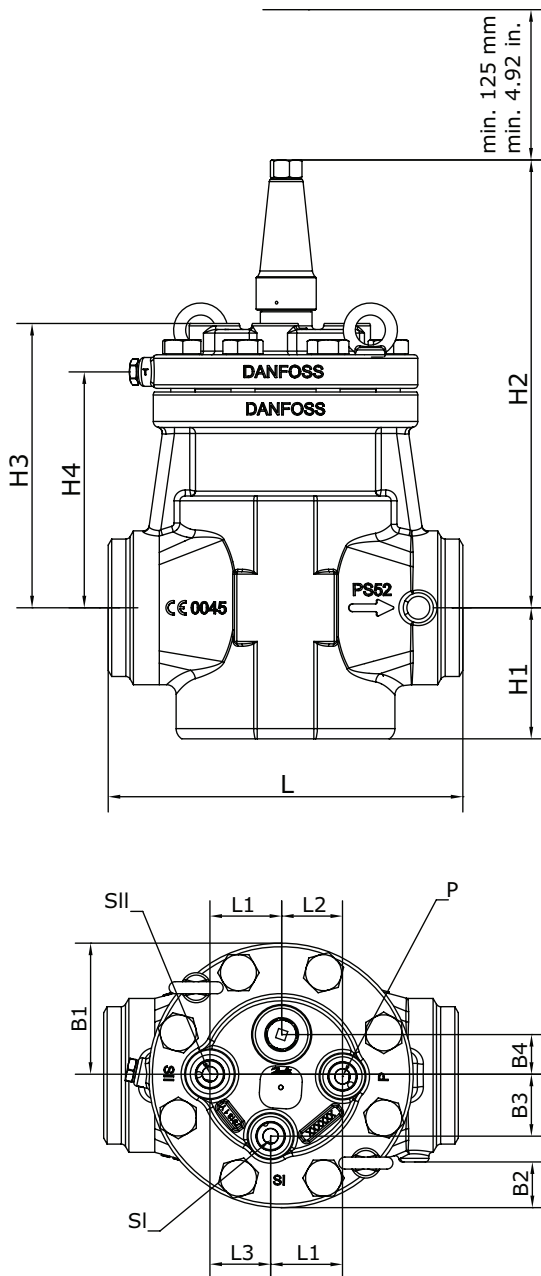

Connection	H1	H2	H3	H4	L	L1	L2	L3	B1	B2	B3	B4	Weight	
100 D or A (4 in.)	mm	109	372	237	196	295	60	51	50	109	38	52	33	45 kg
	in.	4.3	14.7	9.3	7.7	11.6	2.4	2.0	2.0	4.3	1.5	2.1	1.3	99.2 lb.

D = Butt-weld DIN ; A = Butt-weld ANSI

Dimensions and weights - ICS 125

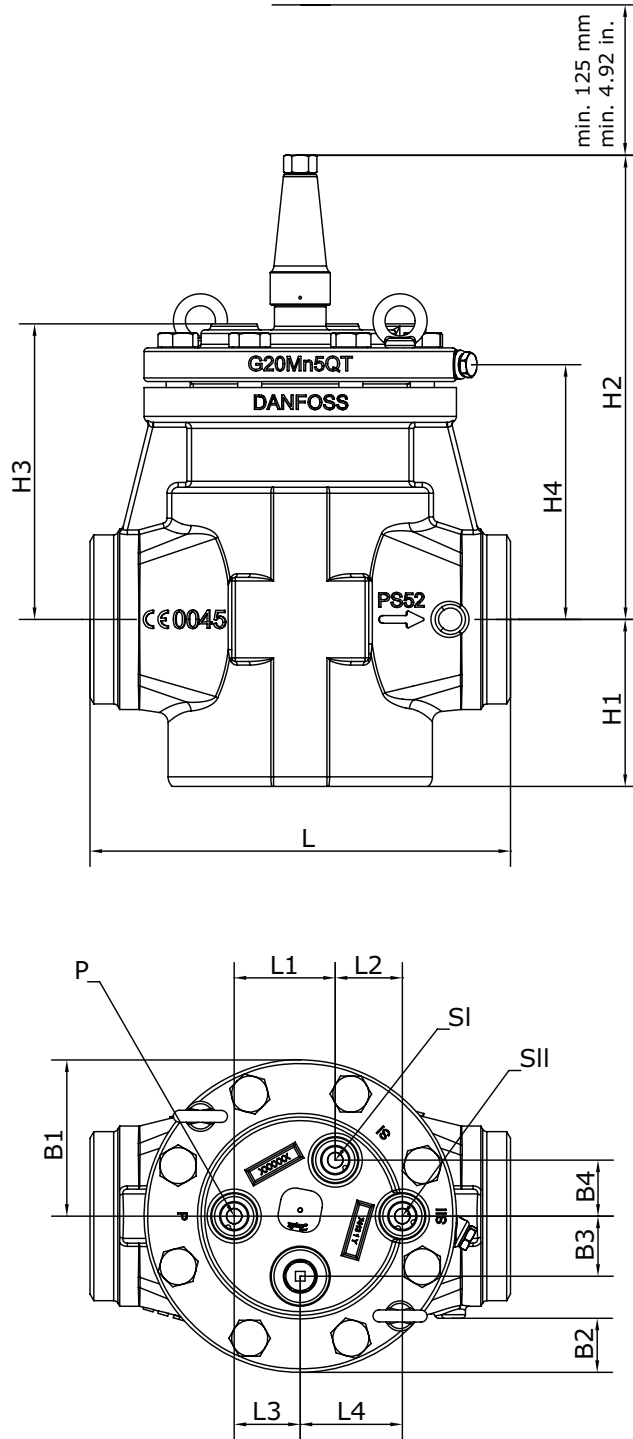

Connection	H1	H2	H3	H4	L	L1	L2	L3	L4	B1	B2	B3	B4	Weight
125 D or A (5 in.)	mm	139	386	246	350	84	56	55	85	130	45	50	47	68 kg
	in.	5.5	15.2	9.7	13.8	3.3	2.2	2.2	3.4	5.1	1.8	2.0	1.9	149.9 lb.

D = Butt-weld DIN ; A = Butt-weld ANSI

Dimensions and weights - ICS 150

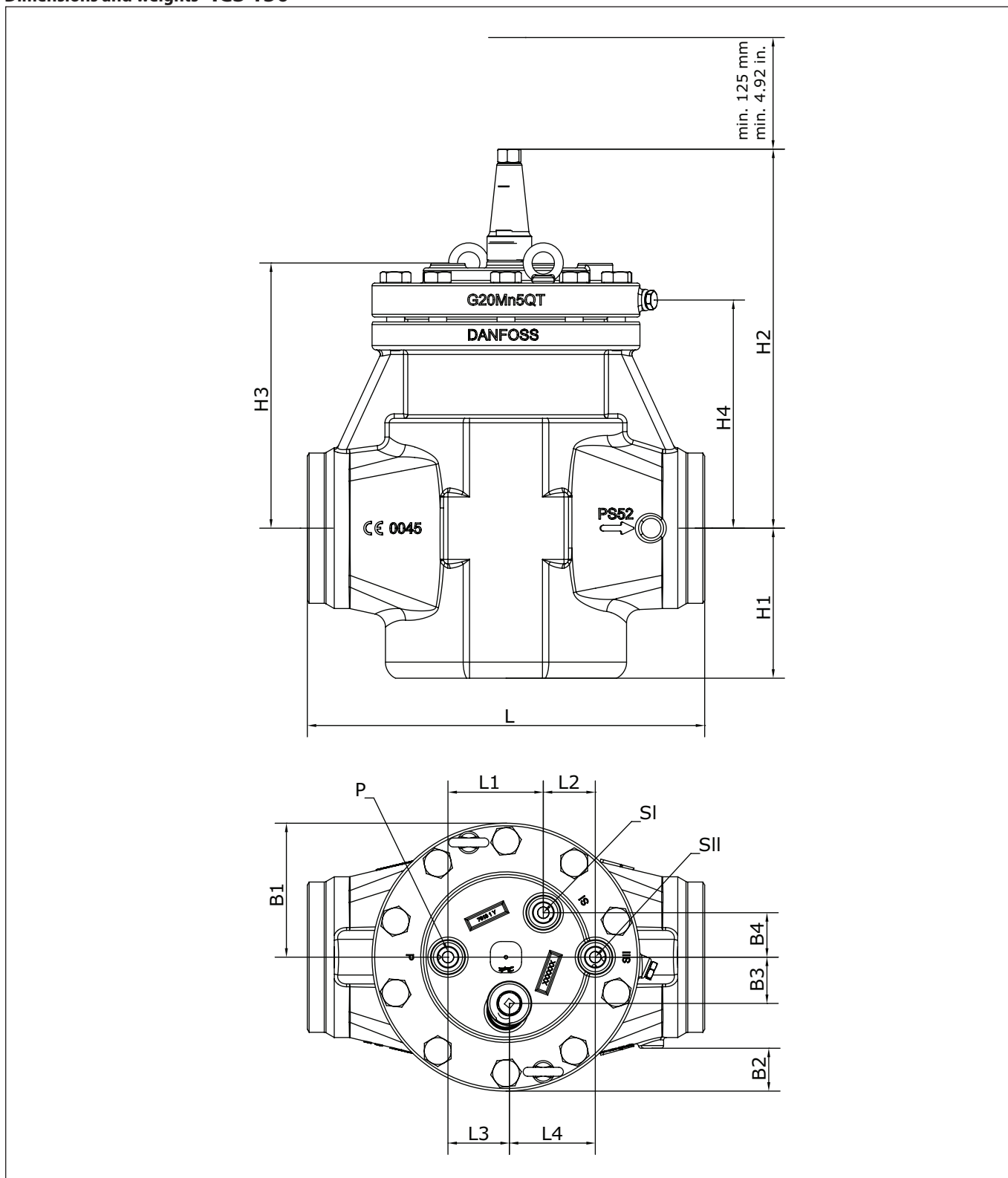

Connection		H1	H2	H3	H4	L	L1	L2	L3	L4	B1	B2	B3	B4	Weight
150 D or A (6 in.)	mm	168	425	297	256	445	107	58	69	96	150	48	52	50	115 kg
	in.	6.6	16.7	11.7	10.1	17.5	4.2	2.3	2.7	3.8	5.9	1.9	2.1	2.0	253.5 lb.

D = Butt-weld DIN ; A = Butt-weld ANSI

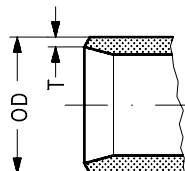
Connections
D: Butt-weld DIN (2448)

Size mm	Size in.	OD mm	T mm	OD in.	T in.		
20	(3/4)	26.9	2.3	1.059	0.091		
25	(1)	33.7	2.6	1.327	0.103		
32	(1 1/4)	42.4	2.6	1.669	0.102		
40	(1 1/2)	48.3	2.6	1.902	0.103		
50	(2)	60.3	2.9	2.37	0.11		
65	(2 1/2)	76.1	2.9	3	0.11		
80	(3)	88.9	3.2	3.50	0.13		
100	(4)	114.3	6	4.5	0.24		
125	(5)	140.7	6.5	5.5	0.26		
150	(6)	168.3	7.1	6.6	0.28		

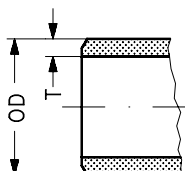
A: Butt-weld ANSI (B 36.10)

Size mm	Size in.	OD mm	T mm	OD in.	T in.	Schedule	
(20)	3/4	26.9	4.0	1.059	0.158	80	
(25)	1	33.7	4.6	1.327	0.181	80	
(32)	1 1/4	42.4	4.9	1.669	0.193	80	
(40)	1 1/2	48.3	5.1	1.902	0.201	80	
(50)	2	60.3	3.9	2.37	0.15	40	
(65)	2 1/2	73.0	5.2	2.87	0.20	40	
(80)	3	88.9	5.5	3.50	0.22	40	
(100)	4	114.3	6	4.5	0.24		
(125)	5	140.7	6.5	5.5	0.26		
(150)	6	168.3	7.1	6.6	0.28		

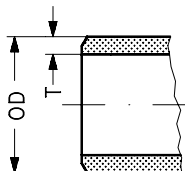
J: Butt-weld JIS

Size mm	Size in.	OD mm	T mm	OD in.	T in.		
(20)	3/4	26.9	4.0	1.059	0.158		
(25)	1	33.7	4.6	1.327	0.181		
(32)	1 1/4	42.4	4.9	1.669	0.193		
(40)	1 1/2	48.3	5.1	1.902	0.201		
(50)	2	60.3	3.9	2.37	0.15		
(65)	2 1/2	76.3	5.2	3.0	0.20		

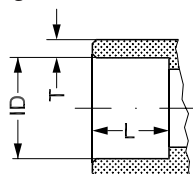
SOC: Socket welding ANSI (B 16.11)

Size mm	Size in.	ID mm	T mm	ID in.	T in.	L mm	L in.
(20)	3/4	27.2	4.6	1.071	0.181	13	0.51
(25)	1	33.9	7.2	1.335	0.284	13	0.51
(32)	1 1/4	42.7	6.1	1.743	0.240	13	0.51
(40)	1 1/2	48.8	6.6	1.921	0.260	13	0.51
(50)	2	61.2	6.2	2.41	0.24	16	0.63
(65)	2 1/2	74	8.8	2.91	0.344	16	0.63

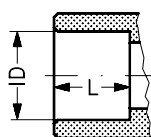
SD: Soldering (DIN 2856)

Size mm	Size in.	ID mm		ID in.		L mm	L in.
22		22.08				16.5	
28		28.08				26	
35		35.07				25	
42		42.07				28	
54		54.09				33	
76		76.1				33	

Connections (continued)

SA: Soldering (ANSI B 16.22)

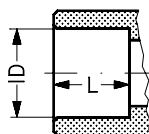

	7/8			0.875		0.650
	1 1/8			1.125		1.024
	1 3/8			1.375		0.984
	1 5/8			1.625		1.102
	2 1/8			2.125		1.300
	2 5/8			2.625		1.300

FPT:
Female pipe thread,
(ANSI/ASME B 1.20.1)

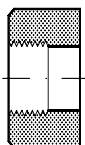

Size mm	Size in.	Inside pipe thread		
(20)	3/4	(3/4 × 14 NPT)		
(25)	1	(1 × 11.5 NPT)		
(32)	1 1/4	(1 1/4 × 11.5 NPT)		

