

DETAIL B
 DETAIL C ROTATED 90 DEG°, MIRRORED
 DETAIL D ROTATED 90°
 SCALE 1/1

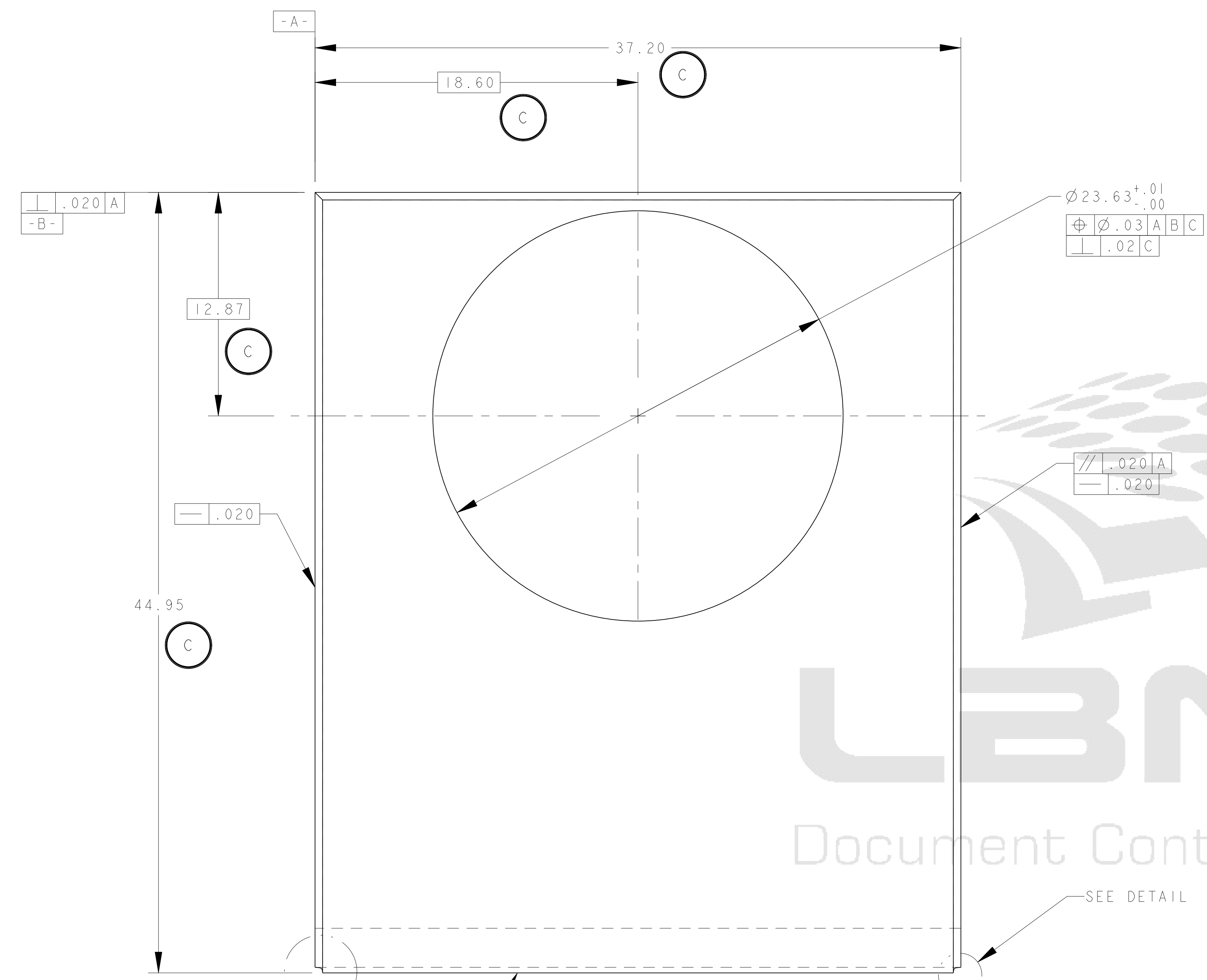

1.25 STOCK
 SEE DETAIL B

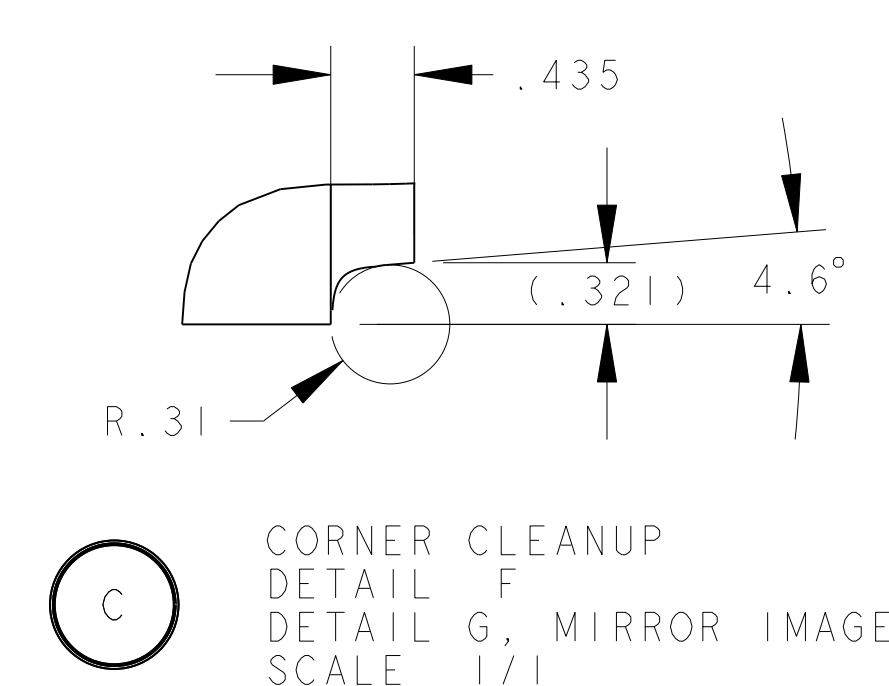
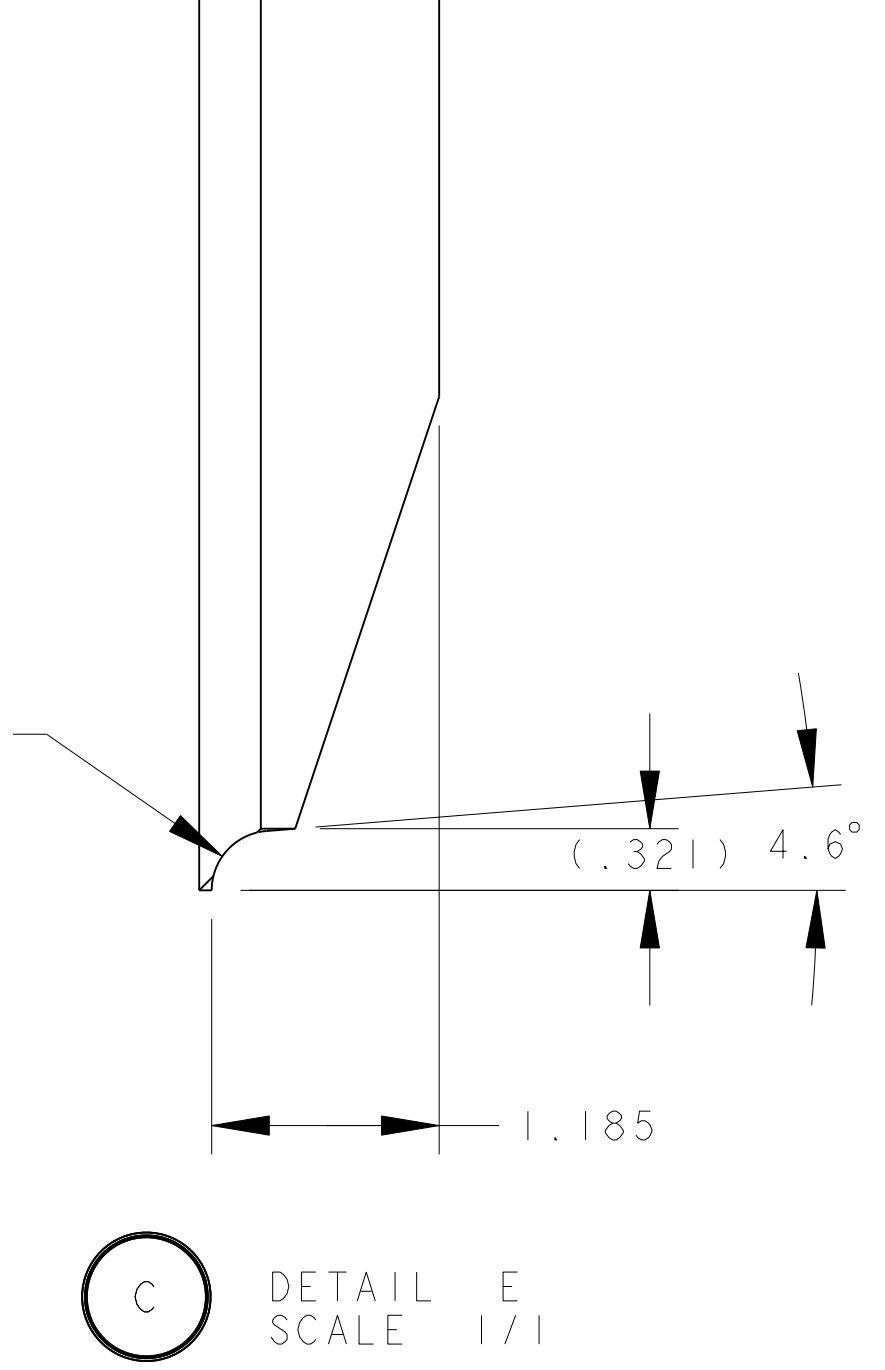
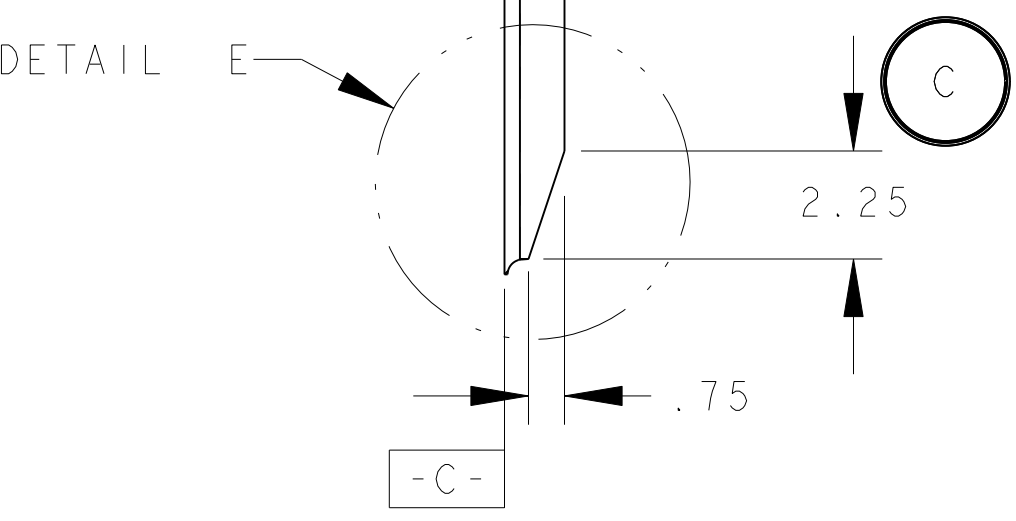
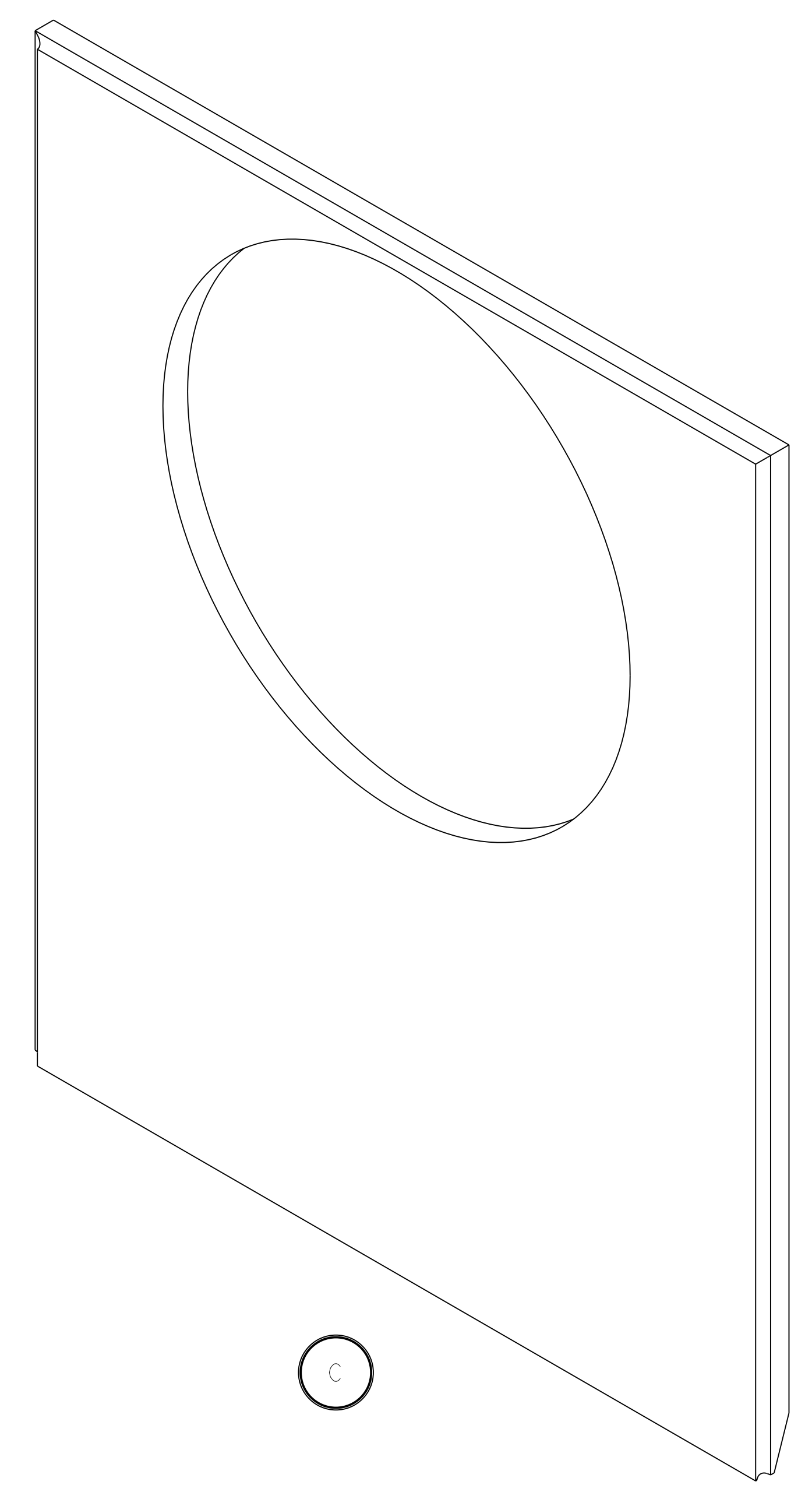

DETAIL G, MIRROR IMAGE
 SCALE 1/1

- NOTES: UNLESS OTHERWISE SPECIFIED.
- DIMENSIONS AND TOLERANCING PER ANSI Y14.5M-1982 UNITS ARE IN INCHES UNLESS OTHERWISE SPECIFIED.
 - USE OF SULFUR OR SILICONE BEARING OILS, LUBRICANTS, OR COOLANTS ARE STRICTLY PROHIBITED.
 - USE OF RESIN OR RUBBER BONDED ABRASIVES UNDER POWER IS STRICTLY PROHIBITED. USE VITREOUS BONDED ABRASIVES ONLY.
 - CLEAN AFTER MACHINING PER VENDOR SPECIFICATION; SUBJECT TO LBNL APPROVAL.
 - PROTECT FINISHED PART BY BAGGING OR SIMILAR METHOD TO PROTECT AND MAINTAIN CLEANLINESS DURING SHIPMENT AND STORAGE.
 - ESTIMATED WEIGHT = 451 LBS

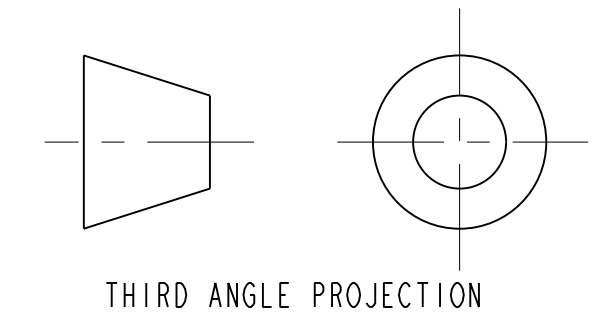

REV	DWG	CHK	ZONE	DATE	DESCRIPTION
C	RLM	JPZ		9/9/03	44.95 WAS 45.70; 12.87 WAS 13.62 37.20 WAS 38.70; 18.60 WAS 19.35 CHANGED ALL WELD PREPS ADDED ISO VIEW; ADDED CHAMFER MINOR COSMETIC DRAWING CHANGES
B	ARH	DPO		03/05/03	MINOR COSMETIC DRAWING CHANGES
A	RLM	DPO		10-4-02	INITIAL RELEASE

UNLESS OTHERWISE SPECIFIED		SHOP ORDERS		ERNEST ORLANDO LAWRENCE	
TOLERANCES	FINISH	NO	YES	BERKELEY NATIONAL LABORATORY	
X.X ± 0.1	FRACTION ± 1/64	NO	YES	UNIVERSITY OF CALIFORNIA - BERKELEY	
X.XX ± 0.03	ANGLES ± 1.00°	NO	YES	LHC IR FEEDBOX	
X.XXX ± 0.010	FINISH: 125 μm	NO	YES	VACUUM	
DO NOT SCALE PRINT		TREATMENT		DI FRONT PLATE	
THREAD ANGLES		TREATMENT TAG		SCALE: 1/4	
CHAMFER ENDS OF ALL SCREW THREADS 30°		TREATMENT		SHEET 1 OF 1	
CUT ROUNDS, 1.5 THREAD RELIEF ON MACHINED THREADS		TREATMENT		DWG. NO. 2511306	
BREAK EDGES .015 MAX. ON MACHINED WORK		TREATMENT		REV. C	
REMOVE BURRS, WELD SPATTER & LOOSE SCALE		TREATMENT		DATE: 15-FEB-02	
IN ACCORDANCE WITH ADP 114-SM-X-ENG-1		TREATMENT		DATE: 15-FEB-02	