

LBNL  
Document Control Center

- NOTES: UNLESS OTHERWISE SPECIFIED,
- DIMENSIONS AND TOLERANCING PER ANSI Y14.5M-1982 UNITS ARE IN INCHES UNLESS OTHERWISE SPECIFIED.
  - USE OF SULFUR OR SILICONE BEARING OILS, LUBRICANTS, OR COOLANTS ARE STRICTLY PROHIBITED.
  - USE OF RESIN OR RUBBER BONDED ABRASIVES UNDER POWER IS STRICTLY PROHIBITED. USE VITREOUS BONDED ABRASIVES ONLY.
  - CLEAN AFTER MACHINING PER VENDOR SPECIFICATION; SUBJECT TO LBNL APPROVAL.
  - PROTECT FINISHED PART BY BAGGING OR SIMILAR METHOD TO PROTECT AND MAINTAIN CLEANLINESS DURING SHIPMENT AND STORAGE.
  - ESTIMATED WEIGHT = 429 LBS

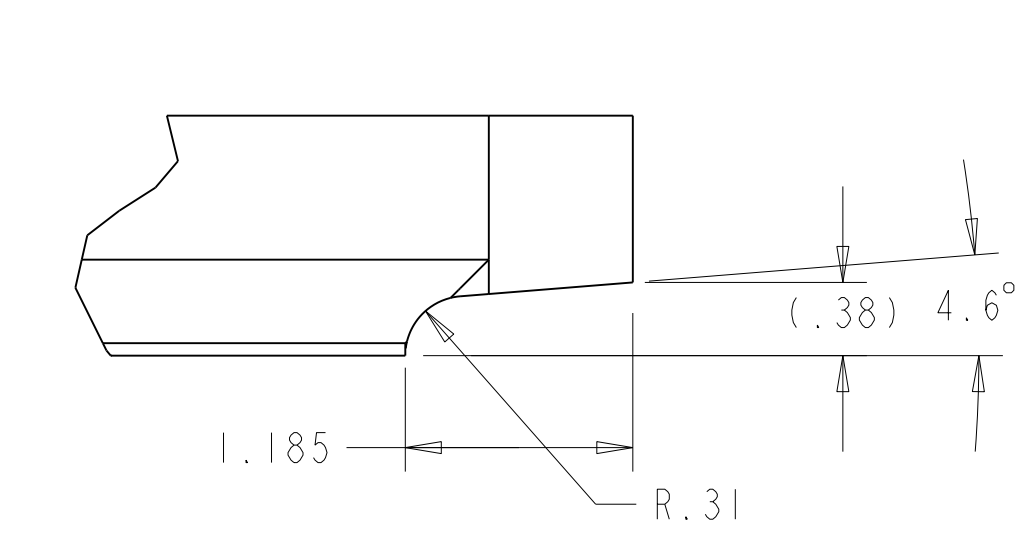

**B** DETAIL B  
DETAIL C MIRROR IMAGE  
SCALE 1/1

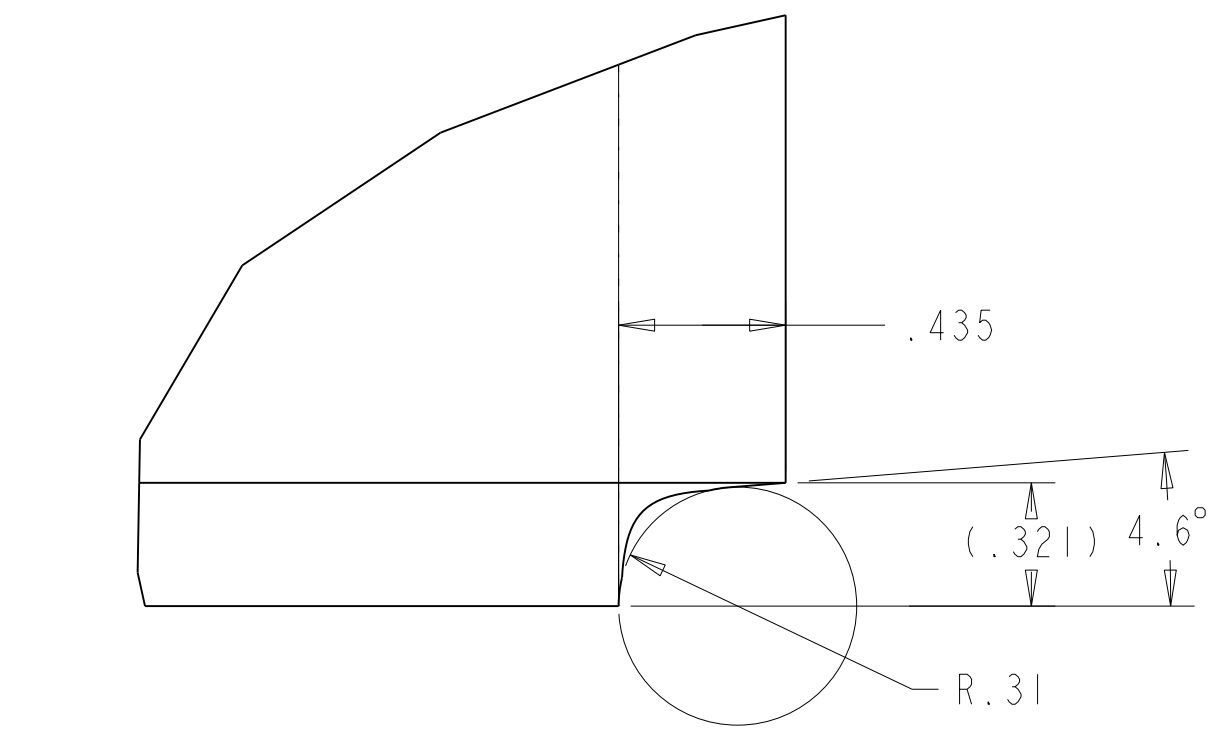

**C** CORNER CLEANUP  
DETAIL F MIRROR IMAGE  
SCALE 2/1

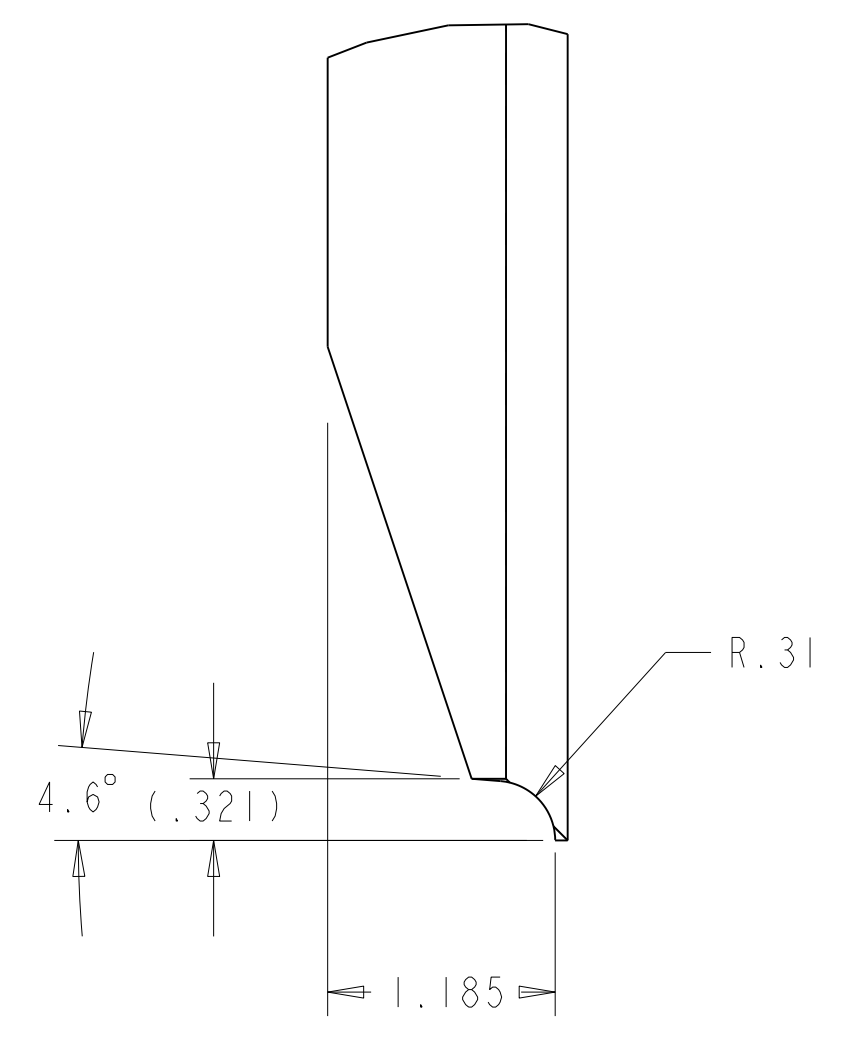

**A** DETAIL A  
SCALE 1/1

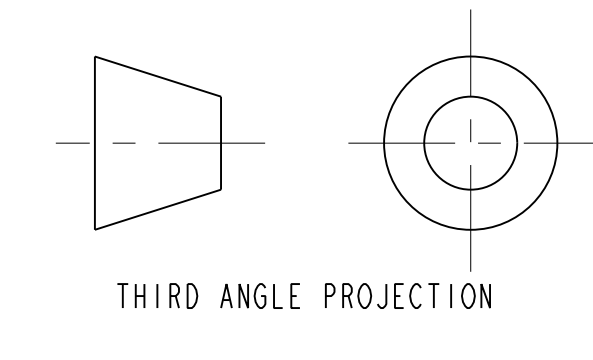

REV	DWG	CHK	ZONE	DATE	CHANGES
A	RLM	DPO		10-4-02	INITIAL RELEASE
B	RLM	JPZ		9/9/03	CHANGED ALL WELD PREPS; ADDED CUT OUTS ADDED CHAMFER CUT; MOVED DATUM C ADDED ISO VIEW
C	RLM	JPZ		2/11/04	OVERALL HEIGHT 57.807 WAS 58.102 64 X .75 WAS 6X. ADD 2X R.38. 4X .75 WAS 5X. ADD .38 DETAIL D: (.35) WAS (.38), .810 WAS 1.185

UNLESS OTHERWISE SPECIFIED		SHOP ORDERS		DESCRIPTION	
X.X ± 0.1	FRACTION ± 1/64	NO	NO	1.25" STOCK PLATE, HOT ROLLED, ANNEALED, PICKLED, ASTM A5240	304L SS
X.XX ± 0.03	ANGLES ± 1.00°	NO	NO		
X.XXX ± 0.010	FINISH: 125 $\sqrt{Ra}$	NO	NO		
DO NOT SCALE PRINT		NO	NO		
TREATMENT: NONE		NO	NO		
CHAMFER ENDS OF ALL SCREW THREADS 1/4"		NO	NO		
BREAK EDGES .015 MAX. ON MACHINED WORK		NO	NO		
REMOVE BURRS, WELD SPATTER & LOOSE SCALE		NO	NO		
IN ACCORDANCE WITH ASME Y14.5M-1994		NO	NO		

MATERIAL	MAT. LOCATION
304L SS	

DATE	BY	DESCRIPTION
13-Aug-01	J. ZBASNIK	DESIGN
15-Feb-02	J. ZBASNIK	DESIGN
15-Feb-02	J. ZBASNIK	DESIGN

DESIGNER	DWG. NO.	SCALE	SHEET	TOTAL SHEETS
J. ZBASNIK	251266	1/4	1	1