

REV	ITEM	PART NUMBER	DESCRIPTION
-	1	-	STAINLESS STEEL TYPE 304
-	2	-	-
-	3	-	-

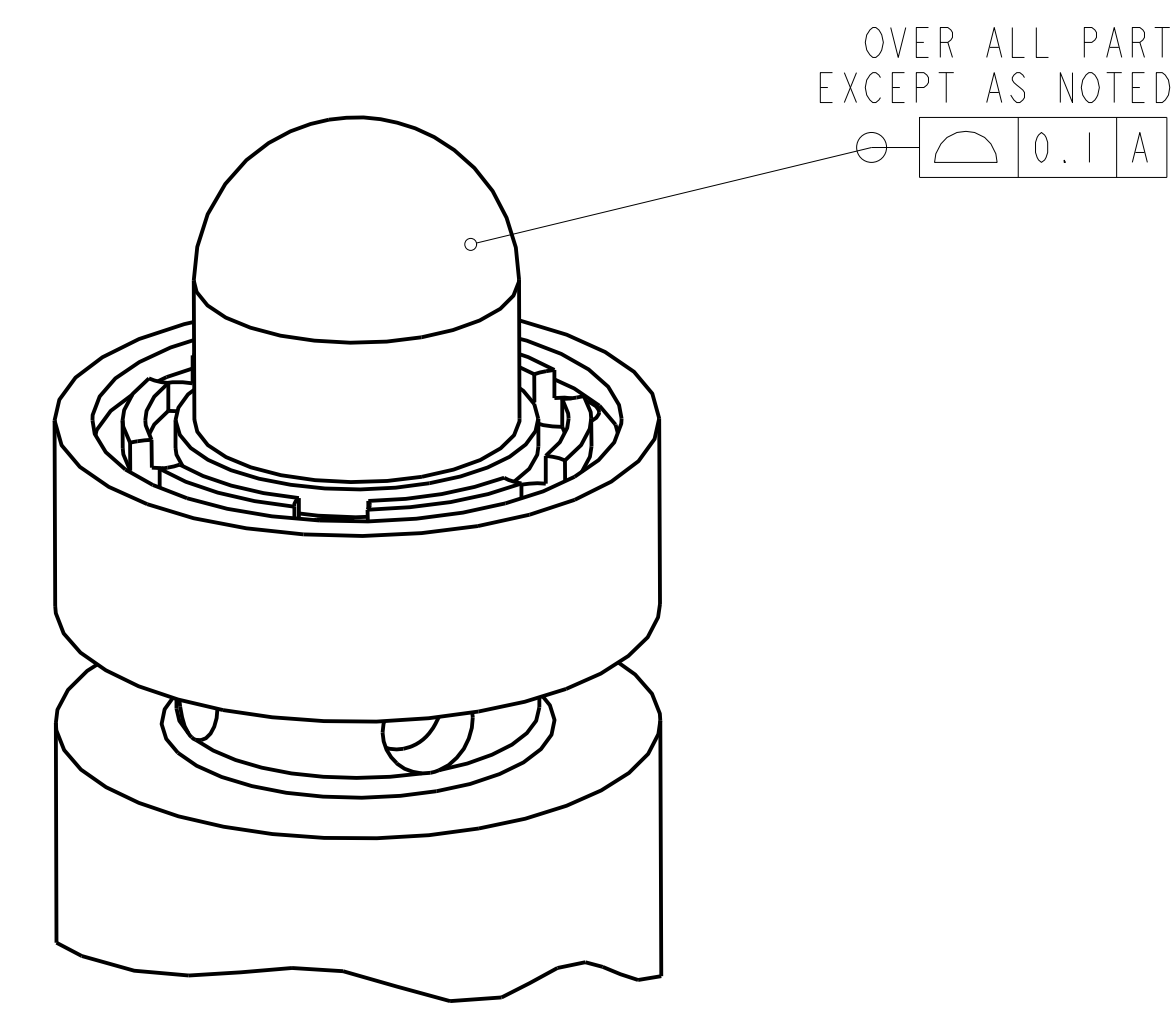
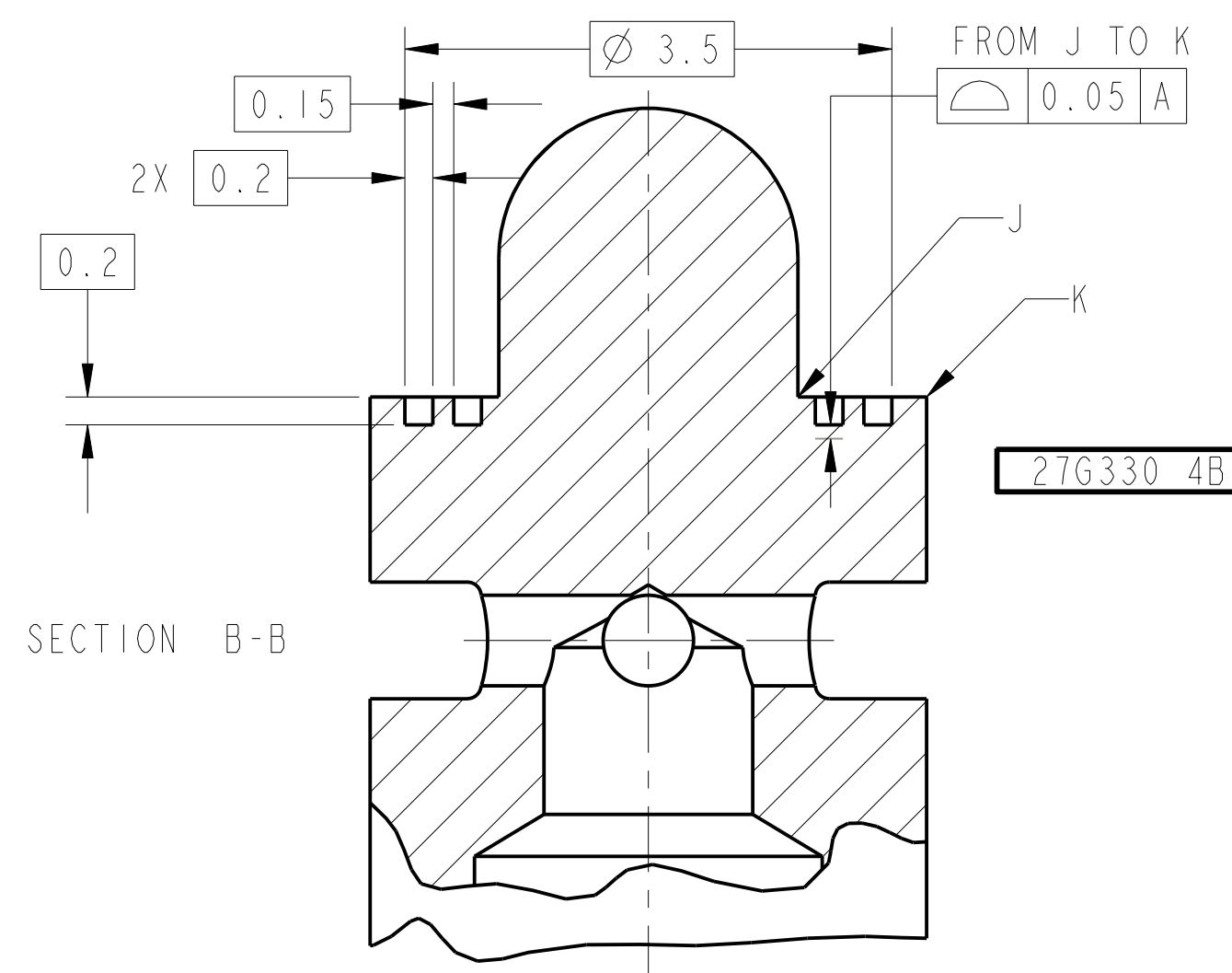
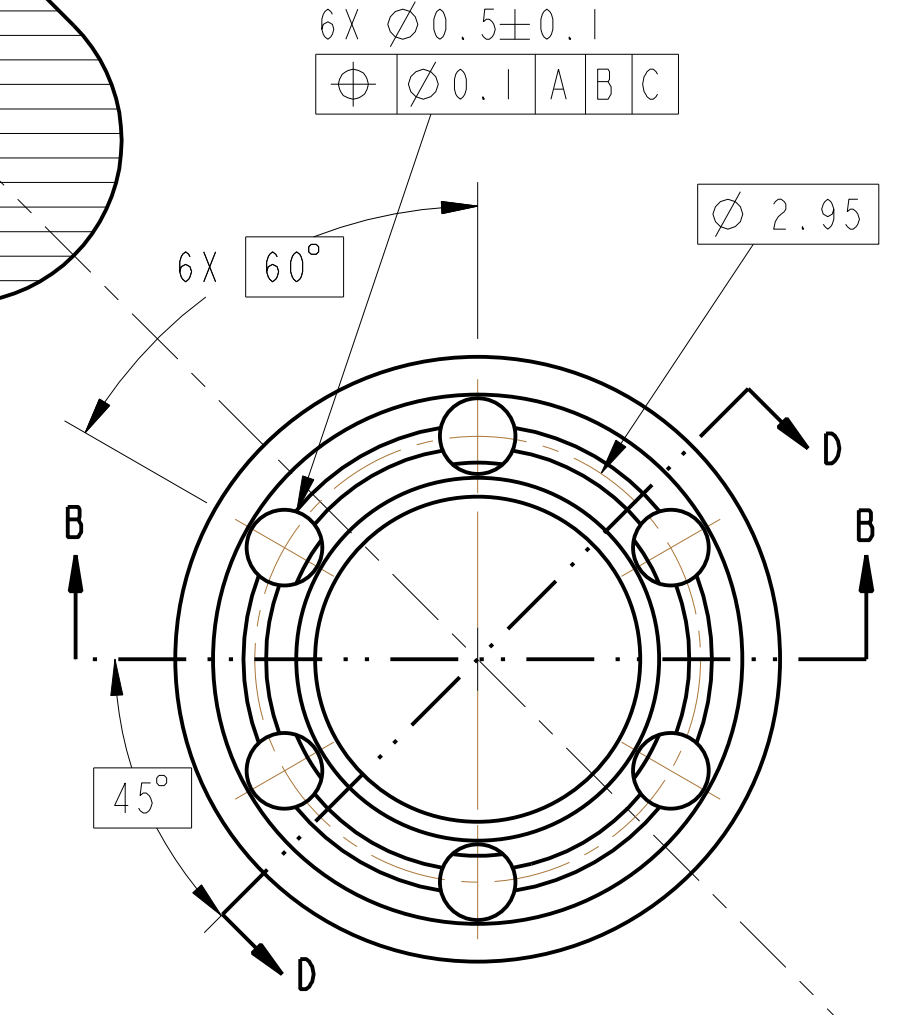
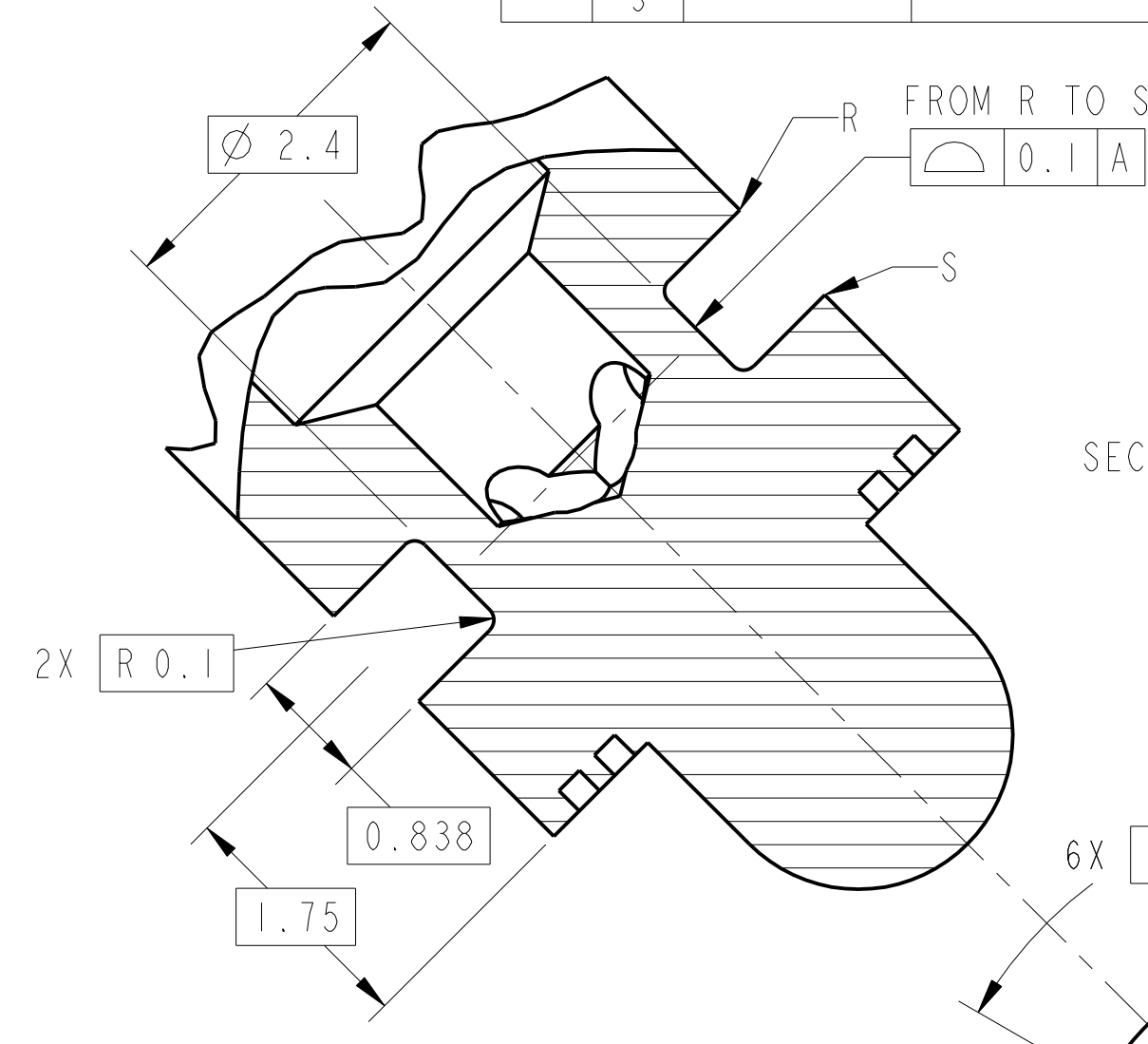
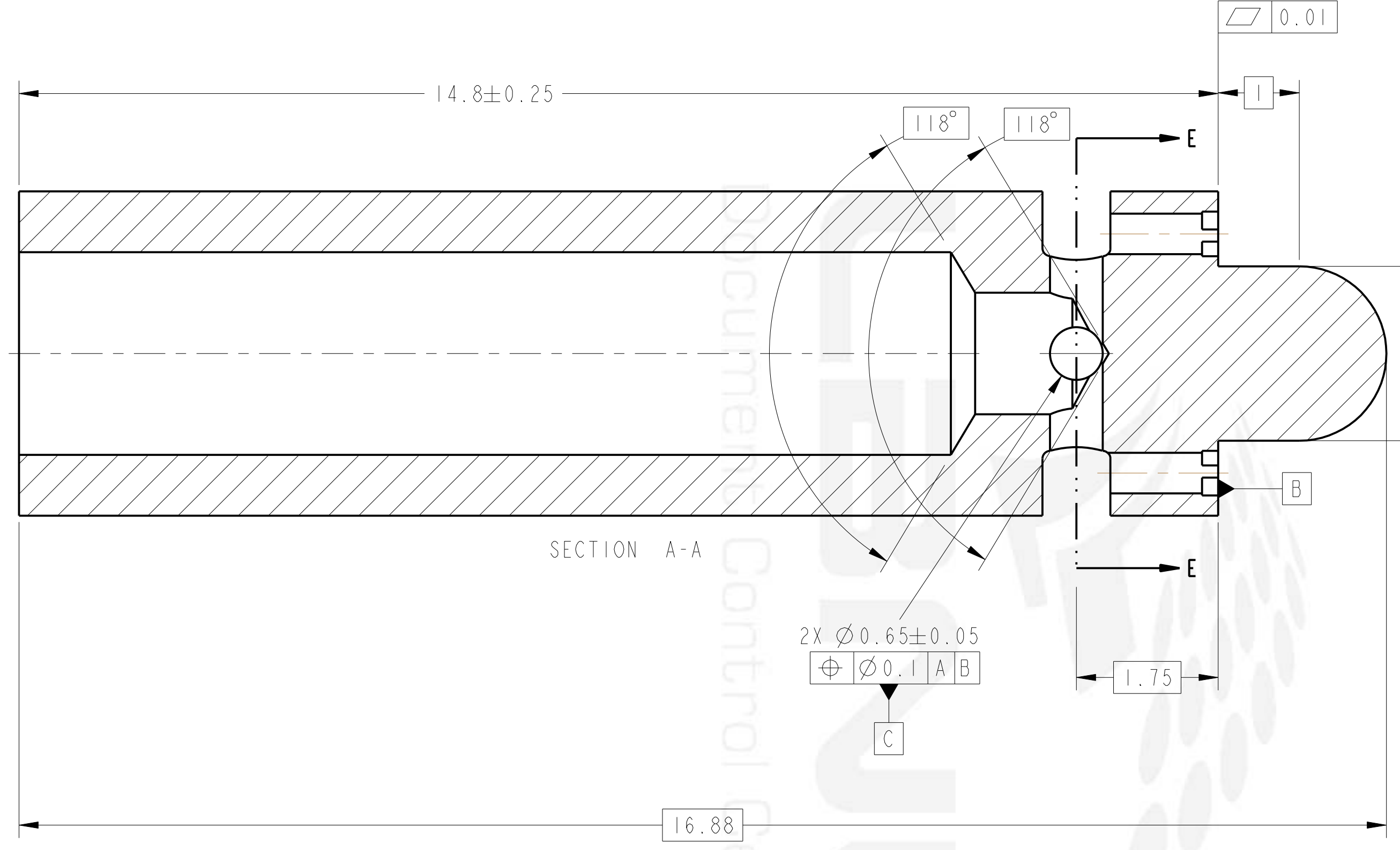
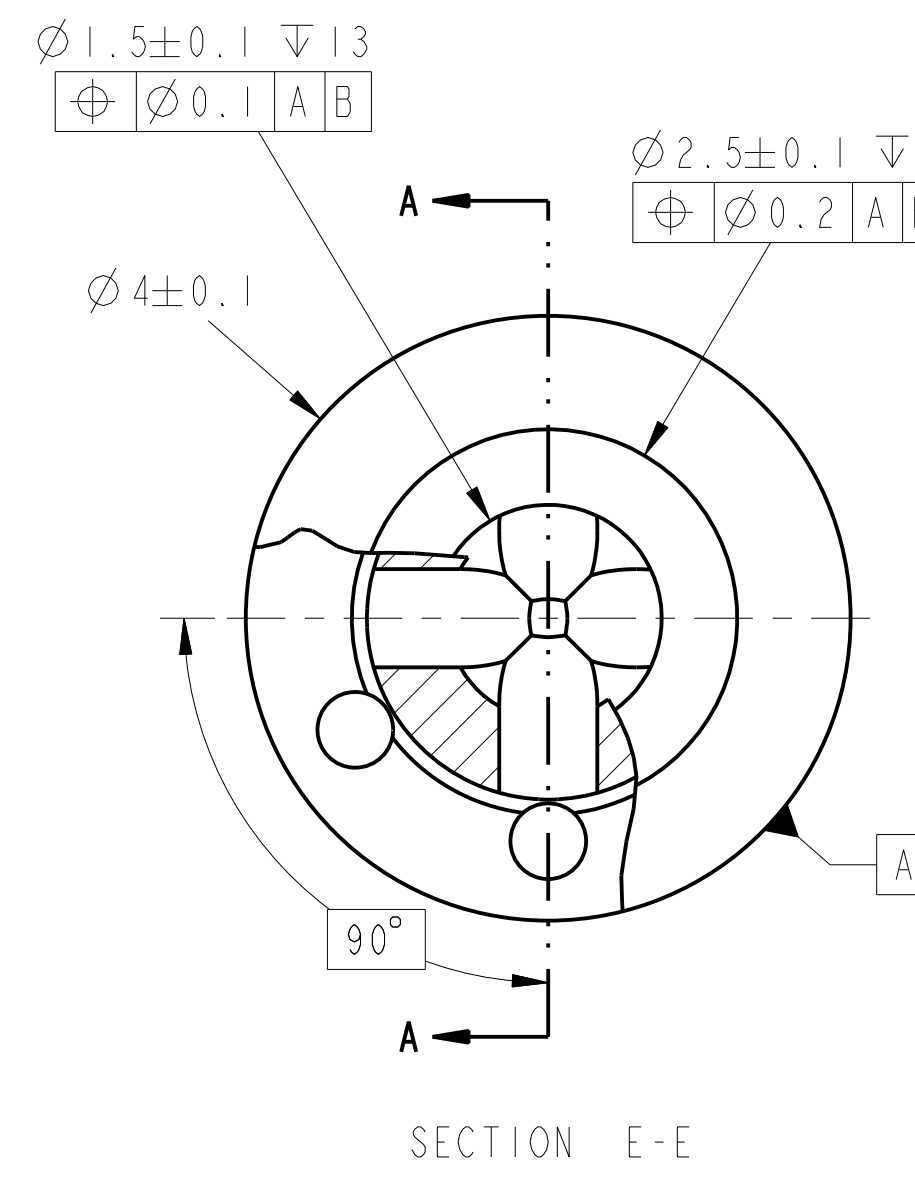

REV	DWG	CHK	ZONE	DATE	CHANGES	UNLESS OTHERWISE SPECIFIED				SHOP ORDERS				LAWRENCE BERKELEY NATIONAL LABORATORY UNIVERSITY OF CALIFORNIA-BERKELEY					
						TOLERANCES	X.X ± 0.1	FRAC. ± 1/64	ACT. NO.	PSNAPO	SERIAL NO.	DATE	NO. RECD	NO. RECD	NO. RECD	SDSS-3 TELESCOPE			
							X.XX ± 0.01	Angles ± 0.50	DATE							SCIENCE FIBER HARDWARE			
							X.XXX ± 0.001	FINISH 125	DELIVER TO:							FERRULE ADHESIVE SPACER INSTALLATION TOOL			
						DO NOT SCALE PRINT				SURFACE TREATMENT Degrease				MICH. FILM: PART					
						THREADS ARE CLASS 2				IDENT. METHOD TAG				SCALE 20.000					
						CHAMFER ENDS OF ALL SCREW THREADS 30°				BY GHIORSO DATE 31-Jul-09				DWG. NO. 27G330 4 B					
						CUT ROUNDS, 1.5 THREAD RELIEF ON MACHINED THREADS				CHK				REV					
						BREAK EDGES 0.04 MAX. ON MACHINED WORK				PSNAPO				CATEGORY CODE RPI000					
						REMOVE BURRS, WELD SPATTER & LOOSE SCALE				DATE				SHOWN ON					
						IN ACCORDANCE WITH ASME Y14.5M & B46.1								27G330 4 B					